



This PDF is generated from authoritative online content, and is provided for convenience only. This PDF cannot be used for legal purposes. For authoritative understanding of what is and is not supported, always use the online content. To copy code samples, always use the online content.

Genesys Info Mart User's Guide

Genesys Info Mart 8.5.0

12/29/2021

Table of Contents

Genesys Info Mart User's Guide	3
About This Document	4
New in Release 8.5.0	5
Genesys Info Mart Overview	9
Terminology	12
Populating Genesys Info Mart Data	15
Populating Interaction Resource Data	18
Populating Interaction Data	30
Populating Mediation Segments	34
Populating Outbound Contact Campaign Activity	39
Populating Agent Activity Data	42
Technical Descriptors	50
Technical Descriptor Combinations	62
Validated Voice Call Flows	76
Diagram Conventions	79
Framework-Only Call Flows: Inbound	81
Framework-Only Call Flows: Outbound	98
Framework-Only Call Flows: Internal	99
IVR-in-Front-of-Switch Call Flows	113
IVR-Behind-Switch Call Flows	119
Universal Routing Call Flows	126
Universal Routing Assisted by IVR-Behind-Switch Call Flows	128
IVR-in-Front-of-Switch Assisted by Universal Routing Call Flows	134
IVR-Behind-Switch Assisted by Universal Routing Call Flows	137
Validated Multimedia Interaction Flows	141
E-Mail Interactions	143
Chat Interactions	165
Data Lineage: Voice of Data	176
Representing Dates and Times of Day	179
Data-Quality Considerations	183

Genesys Info Mart User's Guide

Welcome to the *Genesys Info Mart User's Guide*. This document explains how contact center interactions are represented in the Genesys Info Mart database tables and how to use the data that is stored by Genesys Info Mart for contact center historical reporting.

Information in this guide includes:

- An **overview** of Genesys Info Mart and the Info Mart database table data, showing which dimension tables are associated with each fact table
- Descriptions of how data that is related to interaction-handling attempts, interaction resources, interactions, mediation segments, and contact attempts for Outbound Contact campaigns is populated
- Validated voice interaction flows
- Validated multimedia interaction flows
- How to use the voice-of-data aspect of data lineage
- How dates and times of day are represented

The information is intended for end-users of Genesys Info Mart and is valid only for the 8.5.0 releases of this product.

Starting with release 8.5.014.14 on August 30, 2019, Genesys Info Mart is part of 9.0. This document is valid only for the 8.5 releases of this product before Genesys Info Mart was part of 9.0. For 8.5 releases of Genesys Info Mart after August 30, 2019, see the **Current** version of this document.

About This Document

Intended Audience

This guide is primarily intended for business users who want to query Genesys Info Mart data and for business-application developers who want to develop business-intelligence applications that query the data.

The guide assumes that you have a solid understanding of database-management systems and structured query languages (such as SQL). Familiarity with CTI (computer-telephony integration) concepts, processes, terminology, and applications would also be helpful, as would a basic understanding of the Genesys Framework — its architecture and functions.

Related Resources for Premise Customers

Genesys Info Mart uses source data from several Genesys products. Because of this, Genesys strongly recommends that you read the following documentation in order to better understand the data that is presented in the Genesys Info Mart:

- [Genesys Info Mart Deployment Guide](#)
- [Genesys Info Mart Physical Data Model](#) (formerly known as a *Reference Manual*) for your RDBMS
- [Genesys Info Mart Operations Guide](#)
- [Genesys Info Mart Database Size Estimator](#) (unchanged from 8.1)
- [Genesys Info Mart Business Continuity Deployment Guide](#) (unchanged from 8.1.4)
- [Interaction Concentrator Deployment Guide](#)
- [Interaction Concentrator Physical Data Model](#) for your particular RDBMS
- [Genesys Administrator Extension \(GAX\) Help](#)
- [Framework Configuration Manager Help \(8.1\)](#)
- Genesys Technical Publications [Glossary](#), which provides a list of Genesys and computer-telephony integration (CTI) terms and acronyms
- [Release Notes](#) for this product, which are available on the Genesys Documentation website

New in Release 8.5.0

This page highlights new or changed functionality introduced in Genesys Info Mart 8.5.0 releases, for features that are relevant to the topics discussed in the *User's Guide*. For more information about these and other new features, see the [New in Release 8.5.0](#) page in the *Deployment Guide*.

Important

Starting with release 8.5.014.14 on August 30, 2019, Genesys Info Mart is part of 9.0. For 8.5 releases of Genesys Info Mart after August 30, 2019, see the [Current](#) version of this document.

New in Release 8.5.007

- **Gapless mediation reporting improvement** — In eServices deployments, instead of adjusting the durations of Interaction Queue and virtual queue MSFs to eliminate gaps in mediation reporting, Genesys Info Mart now provides additional MSFs to cover the time that a multimedia interaction is in mediation but is not in an Interaction Queue for which there is an MSF. A new configuration option, `show-non-queue-mediation-mm`, which replaces `expand-mediation-time-for-gapless`, controls whether non-queue MSFs will be created.

The Interaction Queue MSFs, together with the non-queue MSFs, always provide complete coverage of the mediation time up to first handling, since Genesys Info Mart always creates an MSF for the first Interaction Queue that an inbound interaction enters. However, there might still be gaps in mediation following first handling if the first Interaction Queue that the interaction enters during subsequent mediation is not represented in Genesys Info Mart (because of the setting of `populate-mm-ixnqueue-facts`).

For more information, see the discussion about `MEDIATION_DURATION` on the [Populating Mediation Segments](#) page.

New in Release 8.5.006

There are no updates relevant to the purpose of this document.

New in Release 8.5.005

- **Genesys Callback reporting** — Genesys Info Mart supports reporting on Genesys Callback activity on voice, web, or mobile channels, in deployments with Genesys Mobile Services (GMS). Changes to support Callback reporting include:
 - A `CALLBACK_FACT` table and `CALLBACK_*` dimension tables, which were initially introduced in an earlier Genesys Info Mart release

- New technical results, Deferred/CallbackAccepted and Incomplete/Unspecified
- A new interaction subtype, OutboundCallback

For more information, see [Special handling for Genesys Callback](#) in the information about [Populating Interaction Resource Data](#). See also the descriptions of the [Deferred](#) and [Incomplete](#) technical results on the [Technical Descriptors](#) page, and the new Deferred/CallbackAccepted and Incomplete/Unspecified [technical descriptor combinations](#).

New in Release 8.5.004

- **ASM engage duration reporting** — With Outbound Contact campaigns running in an Active Switching Matrix (ASM) dialing mode in VoIP environments, the time that the engaged agent is waiting to be connected to the customer (ASM engage duration) is now reported separately from agent talk time, provided that the new `populate-irf-asm-engage-duration` configuration option is set to `true` (default is `false`). For more information, see the new subsection, [ASM engage metrics](#), in the discussion about population of metrics in the IRF.
- **Reporting on multiple routing attempts** — In deployments with the SIP Server configuration option `divert-on-ringing` set to `false` (in other words, a call that is routed to an agent is not actually diverted from the routing point until the agent answers the call), Genesys Info Mart now associates multiple routing attempts with the same mediation in scenarios when multiple attempts are made to route a call from a virtual queue. Genesys Info Mart now:
 - Uses the same `MEDIATION_SEGMENT_ID` value in the IRF records for all the routing attempts.
 - Reports the technical result of [Redirected/RouteOnNoAnswer](#) for all but the last routing attempt.
 - Includes mediation and routing point durations in the IRFs for all the routing attempts.

For information about minimum SIP Server and ICON releases, as well as ICON configuration, required to support this feature, see the equivalent "New in This Release" entry in the [Genesys Info Mart 8.5.0 Deployment Guide](#).

New in Release 8.5.003

- **Tenant metrics enhancements** — As part of the enhancements that allow Tenant metrics to include active multimedia interactions that have not yet been handled, Genesys Info Mart now always creates a `MEDIATION_SEGMENT_FACT` (MSF) record for the first Interaction Queue that an inbound interaction enters. If the `populate-mm-ixnqueue-facts` configuration option is set to `false` (the default value) in your deployment, you might need to modify custom reports to exclude the first Interaction Queue activity.
- **Multimedia processing improvements**
 - In eServices deployments, Genesys Info Mart now correctly processes scenarios that include a late reply to an e-mail interaction. When a multimedia interaction that represents the reply is created after the parent interaction has already been terminated, the transformation job now processes the child interaction as a separate interaction.
 - New technical descriptor combinations support additional scenarios for multimedia online interactions that are placed into archive queues.

[+] Show related updates in this document

- Information about the reporting implications of a late outbound reply has been added to the [How are IFs populated?](#) section on the [Populating Interaction Data](#) page.
- A new interaction-flow diagram, [Agent Sends Outbound E-Mail](#), illustrates the reporting results when an outbound e-mail interaction is created after the parent interaction has been terminated. The diagram also illustrates the baseline case of any unsolicited outbound e-mail originating with an agent, which is an interaction scenario that Genesys Info Mart always supported.
- In the table of [Technical Descriptor Combinations](#), entries have been added for new Completed/Archived and Completed/Cancelled technical descriptors.
- **Reporting on hunt group call distribution** — Genesys Info Mart now supports reporting on Genesys SIP Server calls that are distributed through hunt groups with parallel or sequential distribution strategy. For accurate data representation, Interaction Concentrator release 8.1.504.04 or later is required.

[+] Show related updates in this document

- A new subsection, [Hunt groups](#) on the [Populating Mediation Segments](#) page, describes the different reporting results for parallel and sequential hunt groups.
- Notes have been added to the [diagram conventions](#) and to various diagrams that illustrate call-flows with ACD queues, indicating what does and does not apply to hunt groups.

New in Release 8.5.002

- **Gapless mediation reporting** — In eServices deployments in which routing activities are performed without the use of virtual queues, a new configuration option, `expand-mediation-time-for-gapless`, enables you to report on routing activities without gaps in mediation time. For more information, see the description of how `MEDIATION_DURATION` is populated in mediation segment fact (MSF) records.
- **Reporting on media-neutral agent states** — A new fact table, `SM_MEDIA_NEUTRAL_STATE_FACT`, supports reporting on media-neutral agent states. For more information, see [Populating Agent Activity Data](#).

New in Release 8.5.001

- **Introduced transfer** — A new role reason and technical result reason, `IntroducedTransfer`, identify IRFs for agents involved in an introduced transfer, and IRF metrics for these agents accrue as they do for transfers. An introduced transfer occurs when the initiator of a conference leaves the conference within a time limit specified by the new `introduced-transfer-threshold` configuration option, while the receiving agent continues on the call.

[+] Show related updates in this document

- In the tables describing [Resource Roles](#) and [Technical Results](#), `IntroducedTransfer` has been added as a possible role reason or technical result reason associated with the resource role of `ReceivedTransfer` and the technical result of `Transferred`, respectively.
 - In the table of [Technical Descriptor Combinations](#), new entries have been added for the technical descriptors that include the `IntroducedTransfer` role reason or result reason; these parallel the
-

existing technical descriptors for transfers and conferences.

- New call-flow diagrams illustrate the reporting results for [Two-Step Introduced Transfer](#) and [Single-Step Introduced Transfer](#).
- **Chat consultation** — Support for reporting on chat consultations and chat conferences/consultations through a queue affects the technical descriptors that will be reported and the population of various IRF metrics.

[+] Show related updates in this document

- New [Technical Descriptor Combinations](#) have been added, with the technical results of Redirected/Revoked and Redirected/Rejected now applying to InConference and ReceivedConsult IRFs for multimedia (chat) interactions.
 - New interaction-flow diagrams illustrate the reporting results for [Chat Consultation](#) and [Chat Conference Through a Queue](#).
 - An additional comment in the description of the [Agent's Attempt to Conference in Another Agent Fails](#) interaction flow clarifies the receiving agent's resource role in this interaction flow.
 - See also the information about changes to population of IRF metrics in the [Physical Data Model](#) for your RDBMS.
 - **Multimedia performance improvements** — Population of thread-related columns in the ANCHOR_FLAGS table is no longer enabled by default. A new configuration option in the [gim-etl-populate] section, populate-thread-facts, controls whether thread-related metrics will be populated. Enabling this functionality might negatively impact Genesys Info Mart performance.
- [+] Show related updates in this document**
- Descriptions of interaction thread functionality and thread metrics on the [Populating Interaction Data](#) and [Populating Interaction Resource Data](#) pages note that the information applies only if Genesys Info Mart has been configured to populate thread metrics.
 - **Support for Designer applications** — Starting with release 8.1.402.07, reporting on call flows that use Designer-based applications has been enhanced. This enhancement is part of the changes to prepare Genesys Info Mart to support reporting on interaction flows that involve applications developed with Genesys Designer. (Support for Genesys Designer is available in certain Genesys Engage cloud implementations.) For more information about the reporting changes, see [Special handling for Designer applications](#).

Genesys Info Mart Overview

Genesys Info Mart produces a data mart that you can use for contact center historical reporting. The data mart includes a server component, administration graphical user interface (GUI), and database. The Genesys Info Mart server runs a set of predefined jobs to:

- Extract data that has been gathered by Interaction Concentrator from data sources such as Configuration Server, T-Server, Interaction Server, and Outbound Contact Server. Genesys Info Mart stores this low-level interaction data, which is consolidated from Genesys Interaction Concentrator databases (Interaction Databases [IDBs]), in the Info Mart database.
- Transform the low-level interaction data and load it into a dimensional model (or star schemas) in the Info Mart database.

Genesys Info Mart can also be configured to host an aggregation engine that aggregates or re-aggregates the data, and populates Aggregate tables in the Info Mart database. You query the fact and dimension tables in the dimensional model, using Structured Query Language (SQL), to obtain results that enable you to examine the data in detail, identify patterns, and predict trends for your organization.

Genesys Info Mart uses multidimensional modeling to create a constellation of star schemas. These star schemas create a database for storing contact center data that can be retrieved using queries. Star schemas support queries that speed the retrieval of the stored data. Querying the data helps you uncover trends, chart heavy usage times, and reveal patterns in your contact center. In this way, Genesys Info Mart can help you:

- Determine how to measure the efficiency of your contact center in comparison with targeted service goals.
- Determine how best to staff your contact center.
- Understand customer preferences and problem trends.

Info Mart Data

Genesys Info Mart 8.x extracts data from one or more IDBs and produces a data mart for contact center historical reporting. Genesys Info Mart yields data that is read-only and historical (representing some period of time).

The Info Mart database consists of the Global Interaction Database (GIDB) tables, fact and dimension tables (*dimensional model*), Merge tables (used for voice interactions only), Control tables, Staging tables, and Temporary tables.

Tip

GIDB provides the possibility for custom reporting or for drill-down reports from the dimensional model.

This guide focuses on the fact and dimension tables, as they are the primary sources of reporting data.

Fact Tables

Fact tables are the large tables in the middle of a star schema. They represent business measures — for example, how long customers waited in a queue, how long and how often agents put customers on hold, or how long agents talked to customers.

Fact tables are surrounded by a set of slowly changing dimension tables. Fact tables represent a many-to-many relationship between dimensions; that is, there are many facts in a single fact table, and they are related to many dimensions in various dimension tables. Fact tables reference dimensions by using surrogate key columns.

Dimension Tables

Dimension tables describe the attributes of the associated fact table. For example, the dimensions that are related to interactions might include the date and time when each interaction started, the required skills for various service types requested by customers, and the value of various customers to the business.

Data Aggregation

An aggregation engine creates Aggregation tables and aggregates data in environments in which either the Genesys historical reporting presentation layer ([Genesys CX Insights \[GCXI\]](#)) or the [Reporting and Analytics Aggregates \(RAA\)](#) package are deployed. These Aggregate tables are documented in the [Physical Data Model Documentation](#) for your RDBMS.

Subject Areas

Genesys Info Mart contains several subject areas that are of interest for contact center historical reporting — for example, the Interaction, Mediation Segment, or Resource Group subject area. Each subject area is a star schema. For more information about the subject areas and about the fact and dimension tables that are contained in each subject area, refer to the [Genesys Info Mart Physical Data Model](#) for your RDBMS.

Facts and Dimensions Matrix

The figure below maps the relationships between Genesys Info Mart fact tables and dimensions in a bus matrix. The bus matrix represents the dimensionality of fact tables in Genesys Info Mart as consolidated tabular views, enabling you to see the full dimensionality of each fact table easily.

Fact table names are listed in columns in the matrix; dimensions are listed in rows. Click the caption below the figure to enlarge.

The matrix excludes the TENANT and DATE_TIME dimensions, which map to all fact tables. It excludes the media-specific interaction and interaction resource tables, as well as the CTL_AUDIT_LOG table.

	FACT TABLES															
	CALLING_LIST_METRIC_FACT	CALLING_LIST_TO_CAMP_FACT	CAMPAIGN_GROUP_SESSION_FACT	CAMPAIGN_GROUP_STATE_FACT	GROUP_TO_CAMPAIGN_FACT	CONTACT_ATTEMPT_FACT	INTERACTION_FACT	INTERACTION_RESOURCE_FACT	SM_RESOURCE_STATE_FACT	MEDIATION_SEGMENT_FACT	PLACE_GROUP_FACT	RESOURCE_GROUP_FACT	RESOURCE_SKILL_FACT	SM_RES_SESSION_FACT	SM_RES_STATE_FACT	SM_RES_STATE_REASON_FACT
DIMENSIONS																
ANCHOR_FLAGS								X								
ATTEMPT_DISPOSITION						X										
CALL_RESULT						X										
CALLING_LIST	X	X				X										
CAMPAIGN	X	X	X	X	X	X										
CAMPAIGN_GROUP_STATE				X												
CONTACT_INFO_TYPE						X										
DIALING_MODE						X										
GROUP			X	X	X	X					X	X				
INTERACTION_DESCRIPTOR							X									
INTERACTION_RESOURCE_STATE								X								
INTERACTION_TYPE							X	X	X	X						
MEDIA_TYPE						X	X	X	X	X				X	X	X
PLACE						X		X	X	X						
RECORD_STATUS						X										
RECORD_TYPE						X										
RECORD_FIELD_GROUP1						X										
RECORD_FIELD_GROUP2						X										
REQUESTED_SKILL							X									
REQUESTED_SKILL_COMBINATION							X									
RESOURCE						X			X	X	X	X	X	X	X	X
RESOURCE_GROUP_COMBINATIO							X		X					X	X	X
RESOURCE_STATE							X							X	X	
RESOURCE_STATE_REASON																X
ROUTING_TARGET							X									
SKILL													X			
STRATEGY							X									
TECHNICAL_DESCRIPTOR							X		X							
TIME_ZONE						X										
WORKBIN									X							

Bus Matrix View Large

For information about all the fields that make up the facts and dimensions, refer to the [Genesys Info Mart Physical Data Model](#) for your RDBMS. For information about aggregates, see the [Physical Data Model Documentation](#) for your RDBMS.

See also [Terminology](#) for some important clarifications about terms used in this guide.

Terminology

This page describes the usage of terms that have specific meanings in the Genesys Info Mart documentation.

Database, Database Schema, and Database Instance

The word *database* has different meanings in the Genesys Info Mart documentation, depending on the context. It may refer to Genesys components, such as “Interaction Database” or “Info Mart database.” It may also be used in reference to general RDBMS concepts and procedures, such as “database export” or “database replication.”

Where it is significant to refer to a particular organization of tables, views, indexes, and other database objects, the term *database schema* is used. Where it is significant to refer to the RDBMS that manages database files, the term *database instance* is used. This terminology might not necessarily match the terminology that is used by leading RDBMS vendors.

Database Area

The Info Mart database consists of only one schema, which comprises several groupings of tables (GIDB tables, Merge tables, and so on). In this document, the groupings of tables might be referred to as a *database area* — for example, the Merge area.

Data Domains

The scope of Genesys Info Mart activity, in terms of the type of details that it processes, is defined by the configured role of the DAP(s) through which Genesys Info Mart accesses IDB. The data domains correspond to the type of details that each IDB stores — Configuration details, Voice details, Multimedia details, or Outbound Contact details. Genesys Info Mart processes each data domain separately.

Data Source

The immediate source of data for Genesys Info Mart is IDB, which is populated by ICON. The source of data for ICON is Configuration Server, T-Server, Interaction Server, or Outbound Contact Server (OCS), depending on the configured role of the ICON application. In this guide, the term *data source* refers to the upstream data provider — the source of data for ICON.

Available Data Sources

Genesys Info Mart extracts data from all the DAPs in its connections — that is, from all the data sources that populate the IDBs from which Genesys Info Mart is configured to extract data. The ICONs and the extraction DAPs must be enabled in order for Genesys Info Mart to consider them and the associated data sources and IDBs to be part of the deployment. (Enabled means that the **State Enabled** check box on the **General** tab of the **Application** objects is selected.)

Active Data Sources

While Genesys Info Mart will extract data from all available data sources, Genesys Info Mart will wait for delayed data only from active data sources. In a Genesys Info Mart deployment, active data sources are data sources that are:

- Currently monitored by enabled ICONs that are connected to Genesys Info Mart
- Enabled — the **State Enabled** check box on the **General** tab of the T-Server, Interaction Server, or OCS Application object is selected

Voice and Multimedia Interactions

Genesys Info Mart supports reporting on both voice and multimedia interactions.

Voice Interactions

The term *voice interactions* refers to traditional telephony calls.

Multimedia Interactions

The term *multimedia interactions* refers collectively to all interactions that are processed through Genesys eServices/Multimedia solution, such as:

- eServices/Multimedia interactions. E-mail and chat are two of the Genesys-provided media types that Genesys Info Mart currently supports.
- 3rd Party Media interactions (formerly referred to as Open Media). These are interactions of any custom media channel that is supported on top of Genesys eServices/Multimedia. The **Workitem** media type is an example of 3rd Party Media.

Genesys Info Mart processes data that is related to all multimedia interactions in a similar manner.

Workbin Instance and Personal Workbin

Workbin Instance

A workbin can be used to hold interactions for resources of a given type: Agent, Place, AgentGroup,

or PlaceGroup. The Script object of type **Interaction Work Bin** in the Configuration Layer indicates the type of resource.

In the Genesys Info Mart documentation suite, the term *workbin instance* does not simply refer to an Interaction Work Bin object, but also to the resource that is indicated as the owner of the interaction in the workbin.

For example, if an Interaction Work Bin object that is named **Drafts** has been defined in the Configuration Layer for use by Agent resources, the expression “Agent1’s Drafts workbin” refers to a workbin instance that represents the use of the **Drafts** workbin for interactions that are assigned to Agent1.

Personal Workbin

As a special case for workbins of type Agent or Place, *personal workbin* refers to the situation in which Agent or Place resources place interactions in their own workbin instances. The concept of a personal workbin does not apply to AgentGroup and PlaceGroup workbins. To extend the previous example, Agent1 placing an interaction into the **Drafts** workbin — with Agent1 specified as the owner of this workbin interaction — is an example of a personal workbin.

Populating Genesys Info Mart Data

This page provides general information about how Genesys Info Mart populates the data in the Info Mart database. You need this information in order to create meaningful queries for business purposes, as well as to interpret query results correctly.

Bringing Data into Info Mart

Extract, transform, and load (ETL) is performed by two main jobs: **Job_ExtractICON** and **Job_TransformGIM**. Deployments in which the Genesys historical reporting presentation layer (Genesys CX Insights [GCXI] or Reporting and Analytics Aggregates (RAA) is installed also use **Job_AggregateGIM**.

- **Job_ExtractICON** extracts new and changed data from IDBs and stores the data in the GIDB tables, as discussed in [Populating Low-Level Details](#).
- **Job_TransformGIM** transforms the data from GIDB into the dimensional-model (fact and dimension) tables. Depending on configuration, **Job_TransformGIM** also extracts and transforms reporting data from other data streams (for example, Apache Kafka) and stores the processed data in the dimensional model.
- **Job_AggregateGIM** calculates or recalculates metrics and stores them in the aggregate tables in the Info Mart database, based on the data that was added or changed during the last transformation run.

For more information about the Genesys Info Mart jobs, see the [Genesys Info Mart Operations Guide](#). For detailed information about Genesys Info Mart functioning, see the [Genesys Info Mart Deployment Guide](#). For detailed information about the aggregation process, see the [Reporting and Analytics Aggregates documentation set](#).

Important

Genesys Info Mart extracts multimedia interaction data while the interactions are still active, and multimedia interaction records might be updated frequently and over large time intervals. Similarly, although Genesys Info Mart extracts voice interactions only after they have completed, After Call Work (ACW) might cause end timestamps in Info Mart records for call-related activity to be updated in a subsequent ETL cycle. Therefore, the timing of your reporting queries can affect reporting results.

When generating and interpreting reports, remember to allow for data updates that might occur over multiple ETL cycles because of continuing activity during long-lived multimedia interactions or because of ACW after voice or multimedia interactions end. For example, for voice interactions, allow for the maximum amount of time that can be spent on wrap-up activities (usually, the value of the user-event-data-timeout configuration option), as well as for the ETL schedule and ETL execution time. You might need to regenerate reports to guarantee final results.

Populating Low-Level Details

The Global Interaction Database (GIDB) is an area within the Genesys Info Mart database schema in which the low-level interaction data from any number of IDBs is consolidated for further processing.

To populate GIDB, Genesys Info Mart Server extracts data from one or more source IDBs. For voice-interaction records, the merge operation links all records that are related to the same interaction, in both single-site and multi-site deployments. The server loads all extracted (and, if applicable, merged) data into GIDB.

The GIDB tables represent a subset of IDB tables, to better align the lowest level of data details in Genesys Info Mart with the Interaction Concentrator model. The GIDB tables:

- Provide low-level details about a call, party, and party history for voice and multimedia interactions in the GIDB_G_CALL, GIDB_G_PARTY, and GIDB_G_PARTY_HISTORY tables, respectively.
- Store all extracted records that are necessary for Genesys Info Mart reporting purposes from various IDBs, to gather coherent reporting data at the lowest level of detail from the entire contact center in a single data warehouse.
- Use special fields to indicate from which IDB data was extracted.
- Store the data for as long as it is required by customers after Genesys Info Mart further processes (transforms) GIDB data.

Genesys Info Mart Server uses the low-level details data from GIDB tables to produce data that is suitable for end-user reports and to populate the fact and dimension tables that compose the Info Mart dimensional model.

The *Genesys Info Mart Physical Data Model* for each supported RDBMS provides a list of GIDB tables. The meaning of the data in each row within a given GIDB table is the same as in the corresponding IDB record. For example, GIDB_GC_PLACE table in the Info Mart database corresponds to the GC_PLACE table in IDB. Refer to the *Interaction Concentrator Physical Data Model* document for your RDBMS for information about the data stored in corresponding GIDB tables.

The DATE_TIME Dimension

The DATE_TIME dimension enables facts to be described by attributes of calendar date and 15-minute time interval. All interaction-related fact tables use only the DATE_TIME time dimension. No other time-dimension fields are used.

Important

Only UTC timestamps are used in the interaction-related fact tables.

By default, a single DATE_TIME table is configured, but you can set up multiple calendar tables. For example, you might need to support multiple time zones. For details on how to configure multiple DATE_TIME tables, see *Creating Custom Calendars* in the *Deployment Guide*.

For more detailed discussion of the DATE_TIME dimension, see [Representing Dates and Times of Day](#).

The CTL_AUDIT_LOG Dimension

The CTL_AUDIT_LOG dimension table contains data for all transactions that are committed by Genesys Info Mart. Instead of service fields such as ROW_CREATED and ROW_UPDATED appearing in all tables, the CTL_AUDIT_LOG table contains audit information for all records.

All fact table records contain pointers (CREATE_AUDIT_KEY and UPDATE_AUDIT_KEY) to the relevant CTL_AUDIT_LOG table row.

Each row represents a logical transaction that is committed by Genesys Info Mart, identifying the ETL job involved in the transaction and including the minimum and maximum DATE_TIME values (which give the date-time range for the data that is committed in the transaction), and providing the processing status (an internal indicator of the kind of data that is processed).

Populating Specific Types of Data

See the following pages for detailed discussion about:

- [Populating Interaction Resource Data](#)
- [Populating Interaction Data](#)
- [Populating Mediation Segments](#)
- [Populating Outbound Contact Campaign Activity](#)
- [Populating Agent Activity Data](#)

Populating Interaction Resource Data

Genesys Info Mart stores interaction resource facts in the `INTERACTION_RESOURCE_FACT` (IRF) table, one of the core tables that is supplied in Genesys Info Mart. This table facilitates the creation of reports and serves as one of the primary tables from which aggregation tables are populated. (See the [Reporting and Analytics Aggregates documentation set](#) for details on aggregation tables.)

What do IRFs represent?

Genesys Info Mart creates IRFs to represent the involvement of a contact center resource of interest in an interaction. *Resources of interest* in the IRF context are:

- Handling resources — Agents, self-service IVRs, DNs without an agent, and multimedia strategies that handle an interaction (for example, a strategy that sends an AutoResponse). Genesys Info Mart creates a row in the IRF table whenever a new interaction or a new attempt to handle an existing interaction has been started, or when an interaction arrives at a handling resource.
- Mediation resources in which the interaction ends. Genesys Info Mart creates a row in the IRF table whenever an existing interaction terminates while in a mediation resource, such as a queue, routing point, or nonself-service IVR.

The IRF table supplies a single row within the Genesys Info Mart schema, which simplifies the SQL needed to generate reports on the resources that handle interactions within the contact center.

Each IRF represents:

- The contiguous time span of the association between the resource and the interaction
- The particular role played by the resource (the *resource role*)
- The result of the association from the perspective of the resource (the *technical result*)

IRFs are created for completed voice interactions and for both completed and active multimedia interactions. For more information, see [How are IRFs populated?](#)

IRF features

The IRF table:

- For interactions of any media type, provides counts and durations that categorize the time spent on the interaction in various activities, such as time spent in a queue, time spent handling the interaction, and time spent wrapping up the interaction. Because not all IRF activity involves a customer directly, separate counts and durations are included to reflect the time that the customer spent waiting versus being helped.
- Simplifies report queries by integrating conference and consultation durations into the original handling-resource row.

-
- Summarizes the total queue, routing point, and IVR wait times prior to the handling resource and stores the summary data with the handling-resource row in separate columns.
 - Stores response duration per routing attempt, in addition to the initial routing sequence.
 - Records the state of the resource immediately prior to involvement in the interaction, thus enabling reporting of interactions received or initiated during an AfterCallwork or NotReady agent state.
 - Links the IRF to associated MEDIATION_SEGMENT_FACT records (MSFs), to provide information about:
 - The last mediation segment that was involved in the interaction, regardless of whether the interaction was distributed to a handling resource (LAST_MEDIATION_SEGMENT_ID)
 - The interaction resource that originated a transfer, conference, or voice consultation (RECEIVED_FROM_IXN_RESOURCE_ID)

Together with fields in the MSF table that link associated MSFs to the IRF, these fields enable downstream reporting applications to report on transfer details and queue activity, including interactions that were abandoned or cleared in virtual queues.

- If Genesys Info Mart has been configured to populate thread metrics (in other words, populate-thread-facts=true), provides thread metrics and agent-unique metrics for an interaction or thread, which identify whether the IRF represents:
 - This agent's first participation in the interaction (where "this agent" refers to the agent resource that is the subject of the IRF record)
 - This agent's first participation in a reply within the interaction
 - This agent's first participation in the interaction thread
 - This agent's first participation in a reply within this interaction thread
 - The first participation by any handling resource in the interaction thread
- For voice calls, provided that T-Server and ICON have been configured to provide the required data, indicates whether a given resource initiated release of the call.

For detailed information about the columns in the IRF table, see the [Genesys Info Mart Physical Data Model](#) for your RDBMS.

How are IRFs populated?

IRFs represent either the processing of interactions by handling resources (such as agents, self-service IVRs, and extensions/positions without associated agents) or unsuccessful attempts to reach such a handling resource (resulting in the interaction being abandoned in queue or abandoned in routing).

Each IRF row includes all prior queue, routing point, and IVR (nonself-service) counts and durations that were part of the distribution of the interaction to the resource.

The grain of the fact is an accumulating snapshot of the contiguous participation of a contact center handling resource in interaction processing, including time spent wrapping up the interaction.

Movement of a resource from one call to another does not cause creation of a new IRF, but is accumulated in a single fact. For example, when the transferredTo resource in a transfer scenario is moved from a consult call to the original call, this movement is represented in a single fact.

However, if a handling resource is participating in parallel calls, the resource is represented by two separate facts. For example, in a consultation call scenario there are two IRFs for the consulting resource, one for the existing call and one for the consultation call.

Special handling for Genesys Callback

Starting with release 8.5.005, Genesys Info Mart supports reporting on Genesys Callback activity on voice, web, or mobile channels, in deployments with Genesys Mobile Services (GMS). For premise customers, Genesys Info Mart support for Genesys Callback reporting is provided out-of-box. For more information about release and configuration requirements for GMS, ICON, and other components to support Genesys Callback reporting, see the information about setting up historical reporting in the [Callback Solution Guide](#).

Callback applications provide Callback-related data that Genesys Info Mart processes and stores in dedicated CALLBACK_* tables, which were initially introduced in an earlier Genesys Info Mart release. The CALLBACK_FACT (CBF) table stores callback-specific facts, based on information GMS sends in UserEvents. There is one CBF record for each UserEvent that has callback information. For more information about the Callback-related tables, see the [Genesys Info Mart Physical Data Model](#) for your RDBMS.

For premise customers, Genesys Info Mart supports Callback reporting for accepted callbacks only.

Genesys Info Mart creates the following IRFs for Callback interactions:

- One IRF for the original customer interaction. The technical result is Deferred/CallbackAccepted, MET_SERVICE_OBJECTIVE=0, and IRF_ANCHOR=1.
- One IRF for each callback media attempt, identified by the new interaction subtype, OutboundCallback. There might be many callback media attempts before the callback completes. Genesys Info Mart treats the media attempts as predictive outbound calls. The technical result of Completed indicates a successful callback; a new technical result, Incomplete, is used in all other cases (for example, the wrong person was contacted or the callback was canceled).

IRFs relate to their associated CBF records via the SERVICE_ID. There are no MSFs associated with either the original call or the callback media attempts.

Without the special handling, Genesys Info Mart:

- Treats the original interaction as being abandoned by the customer. Depending on how long the callback spent in the virtual queue and on the chunk size, Genesys Info Mart might populate an MSF for the virtual queue with a technical result of Diverted.
- Treats failed media attempts as being abandoned by the customer.

Special handling for Designer applications

Starting with release 8.1.402.07, in preparation for supporting interaction flows that involve applications developed with Genesys Designer, Genesys Info Mart provides alternative reporting for

voice call flows that use Designer applications; these applications are loaded on a routing point and consist of self-service and assisted-service phases. (Support for Genesys Designer is available in certain Genesys Engage cloud implementations.)

- If the call ends during the self-service phase of the Designer application, instead of creating an IRF for the routing point with a technical result of CustomerAbandoned/AbandonedWhileQueued, Genesys Info Mart creates an IRF for the Designer application, just as it would for any other self-service IVR application. The entire time that was spent in the application is represented as handling or talk time, and the technical result is Completed/Unspecified.
- If the call leaves the self-service phase and then is either routed to an agent from the assisted-service phase or abandoned from the assisted-service phase, Genesys Info Mart reports the time spent in the self-service phase as `IVR_PORT_DURATION` in the resulting IRF for the agent or routing point. `ROUTING_POINT_DURATION` encompasses the total time spent in the application and overlaps with `IVR_PORT_DURATION`.

The following table summarizes the reporting results for interaction flows that involve Designer applications.

IRF Resource	Technical Descriptor	Customer Handle Count	Talk Count/ Duration	Mediation Count	Routing Point Duration	IVR Port Duration
Scenario 1: Call ended or abandoned in the self-service phase						
An inbound call arrives at a routing point, RP 123, where the Designer application named TestApplication is running. The self-service phase is entered and 10 seconds is spent playing messages, presenting menu options, and so on. After 10 seconds, either TestApplication ends the call or the customer hangs up.						
TestApplication	Received/ Completed/ Unspecified	1	1/10	0	0	0
Scenario 2: Call abandoned in the assisted-service phase						
An inbound call arrives at a routing point, RP 123, where the Designer application named TestApplication is running. The self-service phase is entered and 10 seconds is spent playing messages, presenting menu options, and so on. After 10 seconds, the assisted-service phase is entered, and the call spends 2 seconds in assisted service before the customer hangs up, before being routed to an agent.						
RP 123	Received/ CustomerAbandoned/ 0 AbandonedWhileQueued	0	0/0	2	12	10
Scenario 3: Call routed to agent						
An inbound call arrives at a routing point, RP 123, where the Designer application named TestApplication is running. The self-service phase is entered and 10 seconds is spent playing messages, presenting menu options, and so on. After 10 seconds, the assisted-service phase is entered, and the call spends 2 seconds in assisted service before being routed to Agent1 and then handled by the agent for 60 seconds.						
Agent1	RoutedTo/ Completed/ Unspecified	1	1/60	2	12	10

Special handling for “runaway strategies”

Special logic protects Genesys Info Mart from being overwhelmed by strategies that cause very large quantities of Party, Virtual Queue, and Party History records in IDB. In most cases, having very large numbers of parties and virtual queues involved in a single interaction results from inappropriate strategies, which generate excessive numbers of unsuccessful attempts to route interactions to a handling resource. For example, a strategy might be configured to pull a batch of multimedia interactions from an Interaction Queue, attempt to route the interactions, place the interactions that it was not able to route back into the Interaction Queue, and retry at 1-second intervals.

In these “runaway strategy” scenarios, the transformation job abbreviates the representation of unsuccessful routing attempts.

Genesys Info Mart’s handling of “runaway strategy” scenarios changed a number of times between the initial 8.1.0 release and release 8.1.401.02, when the max-msfs-per-irf configuration option was introduced, enabling you to control the number of MSF records associated with a single IRF record in the Info Mart database. For more details, see the option description in the [Genesys Info Mart Options Reference](#).

For information about the way that queue and routing point metrics for “runaway strategy” interactions are populated in IRF records, see the IRF column descriptions in the [Genesys Info Mart Physical Data Model](#) for your RDBMS.

Genesys recommends that users in large-scale, production-level environments evaluate their strategy configurations, to minimize the risks to data quality by ensuring that their environments are not susceptible to these types of scenarios.

Dimensions associated with the IRF table

- IRF start and end dates and times are stored as UTC timestamps (START_TS and END_TS) and as references to the DATE_TIME dimension (START_DATE_TIME_KEY and END_DATE_TIME_KEY). For more information, see [Representing Dates and Times of Day](#).
 - The RESOURCE_ dimension indicates the routing point, queue, IVR, or agent that either initiated or handled this resource fact. The RESOURCE_ dimension actually has two references, RESOURCE_KEY and MEDIA_RESOURCE_KEY, which typically refer to the same resource. The following are exceptions:
 - For IVRs, RESOURCE_KEY is for the IVR Application Name and MEDIA_RESOURCE_KEY for the associated DN.
 - For Agents, RESOURCE_KEY is for the Agent, and MEDIA_RESOURCE_KEY for the associated DN.
 - The PLACE dimension indicates the place at which the IRF was processed.
 - The TENANT dimension identifies the tenant of the resource.
 - The TECHNICAL_DESCRIPTOR dimension identifies the resource role and technical result of the IRF. For information about the resource roles and technical results for interaction resources, see [Technical Descriptors](#).
 - The INTERACTION_DESCRIPTOR dimension identifies the customer segment (indicating the value of the customer), the type of service being requested, and the business result of the IRF.
 - The STRATEGY dimension identifies the Genesys routing strategy or IVR application that processed the IRF.
-

-
- The ROUTING_TARGET, REQUESTED_SKILL, and REQUESTED_SKILL_COMBINATION dimensions indicate Genesys Universal Routing Server (URS) activities by identifying the target that was selected and the list of skills that were required to process the IRF.
 - The CUSTOMER dimension represents the ID of the customer that is involved in the interaction.
 - If Genesys Info Mart has been configured to populate thread metrics, the ANCHOR_FLAGS dimension supports metrics about unique agent participation in an interaction or thread. For related information, see [Interaction Threads](#).

Supporting tables

Genesys Info Mart uses the following additional tables to support the IRF table:

- The IXN_RESOURCE_STATE_FACT table contains all the individual states, durations, and interval clips for each state the interaction-fact resource was in during the interaction.
- The INTERACTION_RESOURCE_STATE dimension table contains the states defined for the resource that is handling the interaction.

User data

Many interaction attributes are formally modeled. However, deployment-specific attributes, in the form of user-defined attached data, are also represented in the model.

Genesys Info Mart provides unified user-data processing from both call-related EventUserEvents and call-based TEvents, with flexible data storage that you can configure according to the number and types of user data captured in your contact center environment. A customizable database schema enables you to treat each key-value pair (KVP) field as a fact, a dimension, or both, and to store user data KVPs in a configurable number of user data dimensions and facts that are associated with core fact tables. Genesys Info Mart also processes the user data that arrives after call completion and updates call records accordingly.

There are two kinds of user data:

- High-cardinality user data — Data for which there can be a very large number of possible values. A Customer ID number is an example of high-cardinality user data. You can configure Genesys Info Mart to store the KVP value as a character data type, as a numeric data type, or as a date/time data type.
- Low-cardinality user data — Data for which there is a limited range of possible values. Customer Segment, Service Type, and Service Subtype are good examples of low-cardinality user data. For example, in a CUSTOMER table with a column named NEW_CUSTOMER, this column would contain only two distinct values, Y or N, which respectively denote whether the customer was new or not. Because only two possible values are held in this column, its cardinality type is low cardinality.

High-cardinality user data is stored as facts. Low-cardinality user data is most efficiently stored as dimensions. You can create up to 800 custom low-cardinality user data dimensions. The only limits on the quantity of high-cardinality user data that you store are performance based. There are no absolute limits.

High-cardinality user data requires only a single join from the IRF table. Low-cardinality user data that is stored as dimensions requires two joins, one to the CTL_UDE_KEYS_TO_DIM_MAPPING table and another to the dimension table.

You can use the same KVP as both fact and dimension. Genesys provides templates for you to configure your own User Data keys.

Important

Be aware that other Genesys applications might use Genesys-defined KVPs. Depending on your reporting needs, you might need to co-ordinate use of Genesys-defined KVPs in your deployment by modifying the behavior of your routing strategies or, on the Genesys Info Mart side, changing the propagation rule for a particular KVP or creating a custom KVP.

For example, by default, the Genesys gateway application for Web Real-Time Communication (WebRTC) uses the ServiceType KVP with a value of WebRTC to indicate that the interaction is a WebRTC call. By default, Genesys Info Mart will store INTERACTION_DESCRIPTOR.SERVICE_TYPE=WebRTC, unless a routing strategy subsequently attached the ServiceType KVP with a different value during the call.

Customer and noncustomer metrics

Each IRF record includes numerous *_COUNT and *_DURATION metrics. There are two categories of metrics:

- Customer metrics (prefixed by CUSTOMER_), which reflect the “customer experience” — that is, how the customer was treated during an interaction
- Noncustomer metrics (not prefixed by CUSTOMER_), which reflect the “handling resource experience” — that is, how the contact center’s handling resources spent time in an interaction

For detailed descriptions of the metrics, see the IRF column descriptions in the *Genesys Info Mart Physical Data Model* for your RDBMS.

The table below summarizes which party is considered to be the customer and which is the handling resource for various types of interactions.

“Customer” and Handling Resource, by Type of Interaction

Type of Interaction	“Customer”	Handling Resource
Inbound	The external party that initiated the interaction to the contact center	The contact center party that receives the interaction
Internal	The internal party that initiated the interaction within the contact center	The contact center party that receives the interaction
Outbound	The external party that is contacted by the contact center	The contact center party that initiated the interaction or, in the case of Outbound Contact, that was offered the interaction for

Type of Interaction	"Customer"	Handling Resource
		handling
Consultation	None	Both contact center parties that are involved in the consultation: <ul style="list-style-type: none"> • The party that initiates the consultation • The party that receives the consultation

Customer metrics

IRFs are created only for contact center resources. As shown in the [table above](#), the customer is generally an external party, for whom no IRF is created. Customer metrics accrue on the IRF for the handling resource, to show the customer experience alongside the noncustomer (handling resource) experience in the same IRF.

In this document, the time that the customer is considered to be present in the interaction is referred to as *customer time*.

Voice

For voice calls, customer time accrues on the IRF for the party that is considered to be the handling resource (as indicated in the [table above](#)), as long as the party that is considered to be the customer is present in the context of the IRF. (For the IRF that represents an outbound or initiated Outbound Contact call, customer dial time accrues even though the customer is not yet present on the call.) Customer time stops accruing at the moment the party that is considered to be the customer releases or is released from the call.

For consultations, as shown in the [table above](#), both the initiator and the receiver of the consultation are handling resources. There is no customer present on the consultation, and no customer time accrues on the IRFs related to the consultation.

For graphical representations of customer time in various call topologies, see [Validated Voice Call Flows](#).

Multimedia

For multimedia interactions, as for voice calls, customer time accrues on the IRF for the party that is considered to be the handling resource (as indicated in the [table above](#)). However, for multimedia interactions, unlike for voice calls, the notion of the customer being present often does not apply. In order for Genesys Info Mart to represent the customer experience for multimedia interactions, all time that the handling resource spends handling a multimedia interaction is considered to be customer time, except for initiated and received consultations (or e-mail collaborations).

For graphical representations of customer time in various interaction topologies, see [Validated Multimedia Interaction Flows](#).

Noncustomer metrics

Noncustomer metrics accrue on all types of IRFs. Noncustomer metrics are divided into separate “buckets” that represent the possible different phases of an interaction — interaction initiated or offered, initiated consult, received consult, post-consult transfer, conference initiated, conference joined.

ASM engage metrics

When Outbound Contact campaigns run in an Active Switching Matrix (ASM) dialing mode, the time that the engaged agent is waiting to be connected to the customer is referred to as *ASM engage duration*. Starting with release 8.5.004, the `populate-irf-asm-engage-duration` option enables you to configure Genesys Info Mart to report ASM engage duration separately from agent talk time in VoIP environments. For more information, see the descriptions of the `IRF.ASM_COUNT` and `IRF.ASM_ENGAGE_DURATION` columns in the *Physical Data Model* for your RDBMS.

Reporting implications

There are two important considerations for your reports:

- **Customer and noncustomer metrics are not necessarily equal** — The counterpart customer and noncustomer metrics (for example, `CUSTOMER_TALK_DURATION` and `TALK_DURATION`) accrue in parallel within a given IRF, but you cannot assume that they will be equal. The respective values of the metrics depend on:
 - The behavior of the parties in the specific interaction. For example, in a voice call topology that includes a conference between the customer and two agents, the customer and noncustomer representations of talk duration will not be the same if the handling resource continues on the conference after the customer hangs up.
 - The type of interaction. For example, in the IRFs for the initiator and the receiver of a consultation, `CUSTOMER_TALK_DURATION` will be 0 (zero), while `CONS_INIT_TALK_DURATION` and `CONS_RCV_TALK_DURATION`, respectively, will be nonzero.
- **Overlapping IRFs** — For noncustomer metrics, the “buckets” that represent the separate phases of an interaction do not overlap within a single IRF, but they can overlap for parallel IRFs. For example, when the handling resource on an inbound interaction initiates a consultation, there will be two parallel IRFs with overlapping `HOLD_DURATION` and `CONS_INIT_TALK_DURATION` metrics.

Recommendations and tips

Observe the following guidelines:

- Do not try to combine customer and noncustomer metrics.
 - Do not expect that the sum of noncustomer metrics will equal the sum of customer metrics.
 - To avoid double-counting time from overlapping IRFs for a given agent, do not combine IRFs that represent initiated consultations with other IRFs for the same agent. Instead, use initiated-consultation IRFs to calculate consultation metrics separately.
 - For voice calls, use customer metrics when the reporting focus is on the customer experience. Use noncustomer metrics when the focus is on the activities of the handling resource(s), regardless of whether the customer party is present on the call.
-

- For multimedia interactions, use customer metrics when you do not want to consider e-mail collaboration or chat consultation time. Use noncustomer metrics when you want to include collaboration/consultation time.
- The `HANDLE_COUNT` and `CUSTOMER_HANDLE_COUNT` fields are useful to identify various interaction scenarios. For example, the following table summarizes the different results in these fields for the resource that is the subject of the IRF (IRF resource), for a number of common scenarios.

HANDLE_COUNT and CUSTOMER_HANDLE_COUNT Values

Scenario	Type of Interaction	HANDLE_COUNT	CUSTOMER_HANDLE_COUNT
Any outbound interaction initiated by an IRF resource	Outbound	1	1
Any interaction offered to an IRF resource that is accepted (answered) by that IRF resource	Inbound, internal, or outbound	1	1
Any interaction offered to an IRF resource that is not accepted by that IRF resource (for example, redirected or abandoned)	Inbound, internal, or outbound	0	0
Any consultation initiated by an IRF resource where there is an <code>InitiatedConsult</code> IRF (in other words, not including chat consultations, for which there is no <code>InitiatedConsult</code> IRF)	Consultation ^a	1	0
Any consultation offered to an IRF resource that is accepted (answered) by that IRF resource	Consultation ^a	1	0
Any consultation offered to an IRF resource that is not accepted by that IRF resource (for example, redirected or abandoned)	Consultation ^a	0	0

a. Strictly speaking, a consultation (collaboration) is not itself a type of interaction; it occurs within the context of an interaction.

Limitation for customer-related voice activity

In general, the IRF table is populated in a way that enables downstream reporting applications to distinguish customer-related activity, including transfers and conferences, from internal agent-related activity — for example, in data and metrics such as the `Technical Descriptor`, `CONFERENCE_INITIATED_COUNT`, and `CUSTOMER_HANDLE_COUNT`.

However, the population of the dimensional model breaks down for consult/transfers and consult/conferences that occur within an existing conference: When a voice interaction contains a conference that involves a customer and more than one agent, and one of those agents initiates a subsequent transfer or conference out of the first conference, there is no clear way to reliably determine whether the customer is still present when the subsequent transfer or conference occurs. Therefore, metrics such as count of customer-related transfers or count of customer-related conferences cannot be calculated reliably, although the equivalent metrics for internal agent-related transfers or conferences can.

Abandoned and terminated interactions

To represent every interaction in the IRF table, rows are created to represent attempts to reach a resource of interest. These rows contain data about queues, routing points, and routing queues in which the interaction has been abandoned in the distribution device by the customer, during a consultation, or during an internal call that was initiated by a resource of interest.

Abandoned interactions

Abandoned interactions are identified as interactions in which the last resource that was involved was not a handling resource. In such cases a row is created to represent an attempt to reach another handling resource. This IRF row contains data from all prior related mediation device segments that were involved with the attempt to reach another handling resource.

Interactions terminated in a mediation IVR or DN (no IVR or agent resource association)

A *mediation IVR* in the context of the IRF table is an IVR resource that is not considered to be self-service because the IVR application (or a URS strategy on its behalf) did not set attached data to indicate self-service. An interaction that terminates in a mediation IVR is considered to be abandoned.

Populating Interaction Data

Genesys Info Mart stores both voice and non-voice interaction facts (IFs) in the INTERACTION_FACT table. This page describes how IFs are populated.

What do IFs represent?

Genesys Info Mart creates IFs to link together all facts related to a given interaction. IFs represent interactions from the perspective of the customer experience. For example, Genesys Info Mart represents every new inbound or outbound interaction as a new IF row; however, for multimedia interactions, an inbound interaction and an associated outbound reply are represented in the same IF.

Each interaction fact represents:

- The time span of the overall interaction
- Information that identifies the interaction parties
- Service indicators

Interaction facts can also be linked to the user data extension tables through keys.

For detailed information about the columns in the INTERACTION_FACT table, see the [Genesys Info Mart Physical Data Model](#) for your RDBMS.

How are IFs populated?

The grain of the fact is an accumulating snapshot that summarizes facts that are related to a given interaction.

- The TENANT dimension is inherited from the underlying IRF that has the lowest ordinal. This is the first resource fact that was created for the interaction, and it generally has the earliest start time. In a network routing solution, all underlying network and premise facts are considered. If premise facts exist, the TENANT dimension is the tenant of the first premise fact; otherwise, the TENANT dimension is the tenant of the first network fact.
- The INTERACTION_TYPE and MEDIA_TYPE dimensions are inherited from the underlying IRF that has the lowest ordinal. This is the first resource fact that was created for the interaction, and it generally has the earliest start time. In a network routing solution, all underlying network and premise facts are considered.

Important

Any multimedia interaction subtype that you have configured in your environment but that is new to Genesys Info Mart is automatically added to the INTERACTION_TYPE table. Once it has been added, you can choose to have Genesys Info Mart disregard that subtype for all future transformation jobs by setting the appropriate value for the IGNORE field. By default, Genesys Info Mart transforms all interactions that have the newly added subtype.

New media types are also automatically added as Genesys Info Mart encounters them. By default, interactions that are associated with new media types are transformed as offline interactions. To set them as online interactions, enter the appropriate value in the IS_ONLINE field in the MEDIA_TYPE table.

For details, see the [Multimedia Interactions](#) page in the *Genesys Info Mart Deployment Guide*.

- The MEDIA_SERVER_ROOT_I_XN_ID acts as a thread ID for interactions that are a continuation of a thread. For more information, see [Interaction Threads](#).
- As noted above, for multimedia interactions, an inbound interaction and an associated outbound reply are usually represented in the same IF. Starting with release 8.5.003, when a multimedia interaction that represents a reply is created after the parent interaction has already been terminated, the transformation job creates a new IF record with a new INTERACTION_ID value. In earlier releases, the transformation job might discard the child interactions during processing, resulting in the loss of metrics related to a late reply.

Interaction Threads

Important

The thread reporting described below is not related to the chat thread reporting introduced in release 8.5.014.09 for Genesys Engage cloud deployments with Advanced Chat.

Each customer interaction is represented in Genesys Info Mart with a new IF, but it is possible that different customer interactions are associated with one another. For example, a new inbound interaction from a customer might be a reply to a previous agent reply to another inbound interaction from that customer. A collection of related interactions is referred to as a thread. Genesys Info Mart indicates this thread relationship by showing the root interaction in the IF record for a descendant interaction.

- The MEDIA_SERVER_ROOT_I_XN_ID identifies the IF that is considered to be the root (original) interaction in the thread. Population of this field depends on Genesys Info Mart's tracking of the thread, which is affected by the configured thread inactivity timeout (the max-thread-duration-after-inactive-in-days option). For an example, see the table below.
- MEDIA_SERVER_ROOT_I_XN_GUID identifies the root interaction GUID, as reported by ICON as the ROOTIRID.

In addition, the IRF is populated with an ANCHOR_FLAGS_KEY that provides metrics about unique agent participation in an interaction or thread.

Tracking thread activity can negatively impact Genesys Info Mart performance and, starting with release 8.5.001, is optional. When populate-thread-facts=false, interactions that belong to the

same thread continue to indicate the same root interaction (by having a common value for MEDIA_SERVER_ROOT_I_XN_GUID in the IF table), but there is no additional processing to populate the IRF.ANCHOR_FLAGS_KEY with additional details about the agent's involvement in the thread, or to consistently populate IF.MEDIA_SERVER_ROOT_I_XN_ID with the interaction ID of the root interaction (indicated by MEDIA_SERVER_ROOT_I_XN_GUID).

The table below provides a sample e-mail scenario to indicate how, if populate-thread-facts=true, Genesys Info Mart tracks the thread relationships for three related IFs, which have the same root interaction GUID: Two of the related IFs are considered to belong to the same thread, but the third one, which occurs after the thread inactivity interval has expired, is considered to start a new thread.

Date	E-mail Interaction	Interaction and Thread IDs in IF	
June 1	InboundNew: <i>Please send me 100 of ItemX and 50 of ItemY. My account number is 1234.</i>		
June 2	OutboundReply 1a from Agent1: ^a <i>Your account has been billed. Your order number is ZZ001.</i>	INTERACTION_ID: 161 MEDIA_SERVER_ROOT_I_XN_ID: Null MEDIA_SERVER_ROOT_I_XN_GUID: Null MEDIA_SERVER_I_XN_GUID: ROOTIRID-1	
June 2	OutboundReply 1b from Agent1: <i>Your order ZZ001 has been shipped.</i>		
June 2	InboundCustomerReply (to OutboundReply 1a): <i>There is a mistake in the billing details for order ZZ001.</i>		
June 15	OutboundReply 2a from Agent2: ^a <i>Correction has been made. Here are the correct billing details...</i>	INTERACTION_ID: 174 MEDIA_SERVER_ROOT_I_XN_ID: 161 MEDIA_SERVER_ROOT_I_XN_GUID: ROOTIRID-1	
Assuming no further activity on this thread and max-thread-duration-after-inactive-in-days=30, Genesys Info Mart closes the thread on July 16.			
July 20	InboundCustomerReply (to OutboundReply 1b): <i>Order ZZ001 arrived. We need</i>	INTERACTION_ID: 249 MEDIA_SERVER_ROOT_I_XN_ID: Null MEDIA_SERVER_ROOT_I_XN_GUID: Null	

Date	E-mail Interaction	Interaction and Thread IDs in IF	
	<i>50 more of ItemY. Same account.</i>		
July 21	OutboundReply 3a from Agent1: ^a <i>Your account has been billed. Your order number is ZZ002.</i>	Note: The MEDIA_SERVER_ROOT_IYN_ID and MEDIA_SERVER_ROOT_IYN_GUID are null because Genesys Info Mart considers this to be a new thread, after the previous thread (associated with INTERACTION_ID=161) was closed because of the inactivity timeout.	
July 22	OutboundReply 3b from Agent1: <i>Your order ZZ002 has been shipped.</i>		
July 22	InboundCustomerReply (to OutboundReply 2a): <i>Based on the price of ItemY in order ZZ002, there is still a problem with the billing for order ZZ001.</i>	INTERACTION_ID: 265 MEDIA_SERVER_ROOT_IYN_ID: 249 MEDIA_SERVER_ROOT_IYN_GUID: ROOTIRID-1	
July 22	OutboundReply 3c from Agent1: ^a <i>You are correct. Your account has been adjusted.</i>		
<p>a. If this reply is the agent's first participation in the interaction, in the reply, in the interaction thread, or in a reply in the interaction thread, the IRF for the agent includes an ANCHOR_KEYS value that indicates the applicable unique-participation metrics.</p>			

Populating Mediation Segments

Genesys Info Mart stores mediation segment facts in the MEDIATION_SEGMENT_FACT (MSF) table. For detailed information about the columns in the MEDIATION_SEGMENT_FACT table, see the [Genesys Info Mart Physical Data Model](#) for your RDBMS. This page describes how Genesys Info Mart arrives at the data that goes into MSF records.

What do MSFs represent?

Genesys Info Mart creates MSFs to describe interaction activity that involves mediation DNs, such as virtual and ACD queues, or multimedia interaction queues and workbins.

The grain spans the time from when the interaction entered the mediation DN to the time that the interaction was abandoned in the mediation DN, cleared from the mediation DN (virtual queue only), or distributed from the mediation DN, including the time that it takes the interaction to be answered by the target resource or to be abandoned while alerting at the target resource.

For voice, only completed ACD and virtual queue activity is populated; for multimedia interactions, both active and completed interaction queue, workbin, and virtual queue activity is populated.

Each MSF represents:

- The particular role played by the queue resource. For information about the resource roles that apply to queues, see [Resource Roles](#).
- The result of the association from the perspective of the queue resource to the target resource, as chosen during routing. For information about the technical results and technical result reasons that apply to MSFs for voice (ACD and virtual queues) and multimedia (interaction queue, workbin, or virtual queue), see [Technical Results](#).

An MSF also includes links to the associated IRF, which is the IRF during which time the mediation that is represented by the MSF occurred.

How are MSFs populated?

An MSF record (or MSF) is created each time that an ACD or a virtual queue is used during interaction processing. An MSF might also be created each time that a multimedia interaction queue or a workbin is used during interaction processing, depending on configuration. For voice, mediation segments are populated in Genesys Info Mart only when the mediation segment is completed. For multimedia, both active and completed mediation segments are populated.

Genesys Info Mart populates mediation segments in the following ways:

- The start time facts represent the start time of the mediation segment (when the interaction enters the queue).
End time facts represent the end time of the mediation segment, which is one of the following:

- The moment at which the interaction is abandoned while in the queue.
- The moment at which the interaction is distributed from the queue to some target resource.
- The moment at which the interaction is cleared from the queue, such as when a routing strategy routes the interaction from a parallel queue, or when it removes the interaction from the queue as it clears the routing targets for which it was waiting.

In releases 8.5.002 through 8.5.006, in eServices deployments where `expand-mediation-time-for-gapless=true`, adjustments might be made to the end times of Interaction Queue MSFs, or to the start or end times of virtual queue MSFs, to eliminate gaps in the reporting of mediation time for multimedia interactions. For more information, see the discussion of [MEDIATION_DURATION](#), below.

For more information about how start and end times are represented, see [Representing Dates and Times of Day](#).

- The TENANT dimension identifies the tenant to which the queue resource belongs.
- The RESOURCE_ dimension identifies the mediation DN resource that is associated with the mediation segment.
- The TECHNICAL_DESCRIPTOR dimension identifies the resource role and technical result of the mediation segment. For information about the resource roles and technical results that apply to mediation segments, see [Technical Descriptors](#).
- The SHORT_ABANDONED_FLAG indicates that, while waiting to be routed from the queue, the customer abandoned the interaction before the configured threshold expired. This flag enables these types of interactions to be filtered from the reports.
- The MET_THRESHOLD_FLAG indicates that the amount of time an interaction waited to be handled by a contact center resource was within a configurable threshold from the perspective of the queue. Waiting time is measured from the time that the interaction entered the queue to the time that it was answered by a contact center resource.
- The ANSWER_THRESHOLD contains the configured value used to calculate the MET_THRESHOLD_FLAG indicator.
- The PLACE dimension identifies the place that is associated with the target of the routing process.
- In addition to the mediation DN resource that is associated with the mediation segment, the RESOURCE_ dimension identifies the contact center resource that was the routing target from the mediation DN.
- MEDIATION_DURATION is the length of time that the interaction was in the ACD queue, virtual queue, or interaction queue or workbin, based on timestamps from T-Server or Interaction Server.
 - In scenarios in which an interaction is bounced between a mediation resource and a strategy as the strategy repeatedly retries busy agents, all the time that the interaction spends in a particular mediation resource is combined into a single MSF record, and the mediation duration includes all the interim strategy time — in other words, all strategy time except the time of the last strategy before the IRF.
 - In the case of an MSF for a virtual queue, the `adjust-vq-time-by-strategy-time` configuration option enables you to control whether the mediation duration includes or excludes time that the interaction spent in the strategy but outside the virtual queue.
 - In releases 8.5.002 through 8.5.006, the `expand-mediation-time-for-gapless` configuration option enables you to control whether the mediation durations of MSFs in eServices deployments include or exclude time that multimedia interactions spend outside an MSF for a queue. In eServices deployments in which routing activities are performed without the use of virtual queues, there will likely be gaps in the reporting if strategy time is excluded. For gapless mediation reporting up to the first handling of the interaction in the absence of virtual queues, enable **expand-mediation-time-for-gapless**. For gapless mediation reporting for mediations following the first handling, also configure `populate-mm-ixnqueue-facts` so that the Interaction Queues you want to include are represented in Genesys Info Mart.

When **expand-mediation-time-for-gapless** is enabled, Genesys Info Mart adjusts the MSFs for Interaction Queues or virtual queues, if present, to eliminate mediation gaps. In releases 8.5.003 through 8.5.006, **expand-mediation-time-for-gapless** is enabled by default. If your eServices deployment uses virtual queues, you must overtly disable **expand-mediation-time-for-gapless** if you do not want virtual-queue MSFs to be adjusted to cover mediation gaps.

Starting with release 8.5.007, when **expand-mediation-time-for-gapless** was discontinued, Genesys Info Mart no longer adjusts the durations of Interaction Queue or virtual-queue MSFs. Instead, if you enable the **show-non-queue-mediation-mm** configuration option, Genesys Info Mart provides additional, non-queue MSFs for multimedia interactions to represent mediation time that occurs outside an Interaction Queue MSF. For more details, see the extended description of the **show-non-queue-mediation-mm** option.

- **ONLINE_DURATION** is the period of time that the interaction was in the ACD, virtual queue, interaction queue, or workbin before the interaction went offline.
- The **INTERACTION_TYPE** and **MEDIA_TYPE** dimensions are inherited from the underlying IRF that has the lowest ordinal. This is the first resource fact that was created for the interaction and it generally has the earliest start time. In a network routing solution, all underlying network and premise resource facts are considered.
- The **RESOURCE_GROUP_COMBINATION** dimension records the virtual queue or queue membership in one or more groups.
- The **WORKBIN** dimension, if populated, indicates the workbin instance that is associated with the workbin mediation. This dimension enables downstream reporting applications to identify the type of resource and the specific resource that is associated with the workbin mediation.
- Provided that **ICON** provides the required information in the **G_ROUTE_RES_VQ_HIST** table, **IXN_RESOURCE_ID** links the MSF to an IRF that is considered to be the master record. In addition, **ENTRY_ORDINAL** indicates the order of entrance of this mediation segment relative to other mediation segments of the same IRF. These fields enable downstream reporting applications to provide detailed reports on mediation activity that was associated with a particular interaction or resource, even for interactions that were abandoned or cleared in virtual queues.

These fields are populated for all MSF records, unlike **TARGET_IXN_RESOURCE_ID** (see below), which is populated in MSF records only for the devices that eventually distribute the interaction to a handling resource.

- **TARGET_IXN_RESOURCE_ID** provides a link between the MSF and the IRF that was the target of the routing process that is associated with the queue. This provides the means to associate the queue with the target of the routing strategy for virtual queue reporting.

For voice interactions, a configuration option, **msf-target-route-thru-queue**, enables you to specify whether Genesys Info Mart considers the next handling resource or the party immediately following the Routing Point to be the routing target, in scenarios in which a call is routed from a Routing Point through a virtual queue and then ACD queue to an agent ("route-thru-queue" scenarios).

- If the target is considered to be the next handling resource, the **TARGET_IXN_RESOURCE_ID** field in the MSFs for both the virtual queue and the ACD queue indicates the agent who ultimately answered the call. Furthermore, the technical result in the MSF for the virtual queue is **AnsweredByAgent**, and the **MEDIATION_SEGMENT_ID** and **MEDIATION_RESOURCE_KEY** fields of the associated IRF are set to the **MEDIATION_SEGMENT_ID** and **RESOURCE_KEY** of the MSF for the virtual queue.
- If the target is considered to be the party immediately following the Routing Point, **TARGET_IXN_RESOURCE_ID** is not populated in the MSF for the virtual queue, and the technical result is **Diverted/Unspecified**.

Hunt groups

Starting with release 8.5.003, Genesys Info Mart supports the SIP Server feature that enables ACD queues to be configured as hunt groups that use either a parallel or sequential call distribution strategy.

Important

For accurate data representation, Interaction Concentrator release 8.1.504.04 or later is required.

Parallel hunt groups

When a call reaches a parallel hunt group, all of the available hunt group members ring in parallel, but only one member of the hunt group potentially handles the call in the end. Genesys Info Mart filters out all the members of the hunt group that do not answer the call (the ring-only members) and reports the hunt group activity as if it occurred in any other ACD queue during mediation towards a single handling resource. In other words:

- An IRF record is created for the hunt group member that answers the call. No IRF records are created for the ring-only members.
- If the customer abandons the call before a hunt group member has a chance to answer, Genesys Info Mart reports the call as abandoned while queued and creates an IRF record for the hunt group.
- If a timeout occurs prior to a hunt group member answering the call, or if no hunt group members are available, Genesys Info Mart reports on whatever occurs as a result of the hunt group configuration in SIP Server. For example, if the configuration specifies a default extension DN to which unanswered calls are diverted, and the default extension answers the call, Genesys Info Mart creates an IRF record for the extension.
- The target of the MSF record for the hunt group is the IRF record that results from the mediation (for example, the IRF record for the hunt group member that answered).

Sequential hunt groups

When a call reaches a sequential hunt group, the available hunt group members ring serially until one of them answers. Genesys Info Mart represents sequential hunt group scenarios as follows:

- IRF records are created for all hunt group members, even the ring-only members. The IRF records for intermediate ring-only members will have a technical result of `Redirected/RouteOnNoAnswer`. The IRF records are populated and linked together similarly to how they would be for any other RONA (route on no answer) scenario.
- If the customer abandons the call before a hunt group member has a chance to answer, IRF records will be created for all ring-only members but not for the hunt group itself.
- If a timeout occurs prior to a hunt group member answering the call, or if no hunt group members are available, Genesys Info Mart reports on whatever occurs as a result of the hunt group configuration in SIP Server. For example, if the configuration specifies a default extension DN to which unanswered calls are diverted, and the default extension answers the call, Genesys Info Mart creates an IRF record for the extension as well as for the ring-only members, and the IRF records are linked together as they would be for any other RONA scenario.
- The target of the MSF record for the hunt group is the IRF record representing the last hunt group member that rang, regardless of whether it answered.

User data

Genesys Info Mart can be configured to store associated user data in MSFs for interactions that are in mediation. Setup, processing, and storage of user data associated with MSFs closely parallels user data in IRFs. The information about user data on the [Populating Interaction Resource Data](#) page applies to MSF user data as well.

By default, Genesys Info Mart does not store associated user data in MSFs. See [below](#) for information about the configuration options that enable this functionality.

Configuration options that control population of queue activity

The [gim-etl-populate] section of the Genesys Info Mart Application object contains options that enable or disable population of certain types of multimedia interaction activity in the MSF table. Some options can also be configured at [Script level](#), to override the application-level settings.

Important

ACD queue and virtual queue activity is always populated.

Starting with release 8.5.007, the show-non-queue-mediation-mm option controls whether non-queue MSFs will be created for multimedia interactions to cover mediation time that is not represented in MSFs for Interaction Queues.

The link-msf-userdata option on individual DN or Script objects controls whether associated user data will be included in MSFs for those queues. Starting with release 8.5.003, you can use the application-level link-msf-userdata-voice and link-msf-userdata-mm options to enable storage of user data in MSFs for all queues for voice and multimedia interactions, respectively. The DN- and Script-level options, if configured, override the application-level settings.

Populating Outbound Contact Campaign Activity

The Genesys Info Mart schema contains a number of subject areas related to Outbound Contact campaign activity. This page provides detailed information about the Contact_Attempt subject area, which is the area that is focused on actual Outbound Contact campaign interactions.

Genesys Info Mart creates contact attempt facts in order to represent the attempts to reach the customer records of a calling list during the course of an Outbound Contact campaign. Record-based columns are populated with data from the first record associated with a particular contact attempt. Starting with release 8.5.012, Genesys Info Mart reporting on Outbound Contact campaigns can include suppressed records, as described in [Reporting on unattempted records](#), below.

Populating contact attempt facts and dimensions

Genesys Info Mart populates contact attempt facts as follows:

- The two references to the DATE_TIME dimension, in addition to the start and end timestamps, represent the start and end time, respectively, of the Outbound Contact attempt. For more information about how Genesys Info Mart represents dates and times of day, see [Representing Dates and Times of Day](#).
- The CAMPAIGN dimension identifies the Outbound Contact campaign that launched the attempt.
- The TENANT dimension identifies the tenant of the campaign.
- The GROUP_ dimension identifies the campaign group (agent group or place group) that is assigned to this campaign.
- The CALLING_LIST dimension identifies the calling list that contains the target record of the attempt.
- The RECORD_TYPE dimension identifies the type of the target record — for example, General or CampaignRescheduled.
- The RECORD_STATUS dimension identifies the status of the target record at the end of the contact attempt — for example, Updated or Cancelled.
- The CONTACT_INFO_TYPE dimension identifies the type of contact information that is provided in the target calling list record — for example, HomePhone or Mobile.
- The CALL_RESULT dimension is used to identify the final call result of the contact attempt (for example, Answer, Busy, or Wrong Party) as well as the dialer result (for example, Answer or Busy) if a dialer was used.
- The RESOURCE_ dimension identifies the resource that is associated with the first agent that corresponds to the Outbound Contact attempt, or an agent who is previewing this record.
- The RESOURCE_GROUP_COMBINATION_KEY dimension identifies the groups of which the Agent resource was a member when the contact attempt was started. This field references the default No Group value if the agent does not belong to a group.
- The PLACE dimension identifies the place that is associated with the first IVR DN or agent that corresponds to the Outbound Contact attempt.

- The `DIALING_MODE` dimension identifies the dialing mode that was used for the contact attempt — for example, Predictive, Progressive, or Preview. For GVP, these dialing modes are `PROGRESSIVE_GVP`, `PREDICTIVE_GVP`, and `POWER_GVP`, respectively.
- The `MEDIA_TYPE` dimension identifies the media type of the interaction that is associated with the Outbound Contact attempt — for example, Voice.
- The `RECORD_FIELD_GROUP_1` and `RECORD_FIELD_GROUP_2` dimensions contain custom fields from the calling list record. The values represent a snapshot that was taken at the end of the contact attempt.
- Record field facts in the `CONTACT_ATTEMPT_FACT` table hold custom field values from the target calling list record. The values represent the snapshot that was taken at the end of the contact attempt.
- State counts and durations summarize the amount of time that is spent on various activities.

Important

The following columns in the `CONTACT_ATTEMPT_FACT` table are no longer populated, although they remain in the schema:

- `IXN_START_TIME`
- `IXN_START_TIME_KEY`
- `CONTACT_IXN_START_TIME`
- `CONTACT_WITHIN_DAILY_RANGE`

To obtain the same data, use the following calculations:

- For `IXN_START_TIME` and `CONTACT_IXN_START_TIME`, make a join between `CONTACT_ATTEMPT_FACT` and `INTERACTION_FACT` on `CONTACT_ATTEMPT_FACT.CALLID=INTERACTION_FACT.MEDIA_SERVER_IXN_GUID`.
- For `IXN_START_TIME_KEY`, use `INTERACTION_FACT.START_DATE_TIME_KEY`.
- For `CONTACT_WITHIN_DAILY_RANGE`, you must also take into account the contact `TIME_ZONE`, which is identified by the `TIME_ZONE_KEY`. For assistance with this calculation, which is situation- and RDBMS-dependent, contact [Genesys Customer Care](#).

Outbound Contact campaign activity fact tables

Genesys Info Mart stores facts about Outbound Contact campaigns and activity in the following tables:

- **Contact attempts:**
 - `CONTACT_ATTEMPT_FACT`
- **Calling lists:**
 - `CALLING_LIST_METRIC_FACT`
 - `CALLING_LIST_TO_CAMP_FACT`

- **Campaigns and campaign groups:**

- CALLING_LIST_TO_CAMP_FACT
- GROUP_TO_CAMPAIGN_FACT
- CAMPAIGN_GROUP_SESSION_FACT
- CAMPAIGN_GROUP_STATE_FACT

For detailed information about the columns in the Outbound Contact campaign fact tables, refer to the [Genesys Info Mart Physical Data Model](#) for your RDBMS.

Reporting on unattempted records

Starting with release 8.5.012, Genesys Info Mart supports reporting on contact list records that were suppressed from an outbound campaign, for campaigns managed by CX Contact release 9.0.000.09 or higher. Previously, unattempted records were excluded from reporting because OCS does not report on records belonging to suppression lists for campaign groups.

Genesys Info Mart stores CX Contact data in the following tables, which you can use to supplement existing reporting about contact attempts, campaign activity, and calling list usage sourced from OCS:

- LDR_FACT — Describes contact list records that CX Contact reported as unattempted.
- LDR_CAMPAIGN — Allows CX Contact record facts to be described based on characteristics of the outbound campaign.
- LDR_DEVICE — Allows CX Contact record facts to be described based on device characteristics of the contact list records.
- LDR_GROUP — Allows CX Contact record facts to be described based on the name of the agent group or place group associated with the outbound campaign.
- LDR_LIST — Allows CX Contact record facts to be described based on characteristics of contact lists.
- LDR_POSTAL_CODE — Allows CX Contact record facts to be described based on postal code values of contact list records.
- LDR_RECORD — Allows CX Contact record facts to be described based on contact information type, record type, record status, and disposition.

Populating Agent Activity Data

Genesys Agent activity data for both active and completed agent states is stored in summary tables for resource sessions, states, and reasons relative to a given media type, for all media types. The summarized data, which is drawn from ICON, is stored in the following tables:

- SM_RES_SESSION_FACT
- SM_RES_STATE_FACT
- SM_RES_STATE_REASON_FACT

Starting with release 8.5.002, the SM_MEDIA_NEUTRAL_STATE_FACT table stores the summarized states for each agent resource across all media.

Features of agent activity data

The following are important, configurable features of agent activity data in Genesys Info Mart:

- **Do-Not-Disturb** — Do-Not-Disturb (DND) status for each DN (or place and media type in the case of eServices/Multimedia) can optionally be factored into the SM_RES_STATE_FACT and SM_RES_STATE_REASON_FACT tables, depending on the setting of the factor-dnd-into-sm-resource-states configuration option on the Switch object.

DND is treated as a NOT_READY state, with the predefined software reason key DND 0n and no reason value. The termination of the DND state is treated as a READY state. For more information, see [Including Do-Not-Disturb data in summary tables](#).

- **Agent state hierarchy** — Agent states are organized in a hierarchy, so that a higher-priority state takes precedence if multiple states happen simultaneously. The default priority list (in descending order) is ACW, NOT_READY, BUSY, READY.

You can change the hierarchy of states in the summarized resource state tables by adjusting the settings for the sm-resource-state-priority configuration option. However, be aware that, for parallel states, the state that is reported in the SM_RES_STATE_FACT, SM_RES_STATE_REASON_FACT, and SM_MEDIA_NEUTRAL_STATE_FACT tables also depends on whether ICON has been set to interrupt After Call Work (ACW) and NotReady states when an agent places or receives another interaction (see [Obtaining uninterrupted voice AfterCallWork and NotReady data](#)).

- **Uninterrupted voice ACW and NotReady data** — Genesys Info Mart can represent voice ACW and NOT_READY states and reasons that are sourced from ICON and have these states not be interrupted by incoming or outgoing calls that an agent makes while in these states. For more information, see [Obtaining uninterrupted voice AfterCallWork and NotReady data](#).

How are summarized resource sessions, states, and reasons populated?

The SM_RES_SESSION_FACT, SM_RES_STATE_FACT, and SM_RES_STATE_REASON_FACT tables incorporate all data during the period in which an agent is logged on to a particular media type, regardless of the number of DN's or queues to which the agent logs on. By default, agent activity for all media types is included in the tables, but you can exclude certain media types by setting the applicable **populate-sm-<media type>-resource-activity** option in the [\[gim-etl-populate\] configuration section](#) to false. Starting with release 8.5.002, the SM_MEDIA_NEUTRAL_STATE_FACT table stores the

summarized states for each agent across all media for which Genesys Info Mart stores agent activity data.

The media-specific summarized tables are populated based on the start and end time taken from corresponding IDB fields of the date format, in order to achieve precision in scenarios with very short agent states.

- For voice, the start and end times are taken in milliseconds, and this precision is used in internal calculations for summary voice agent states, reasons, and sessions. This ensures, for example, the proper alignment of multiple agent states that occur within the same second. The time values that result from calculations, including durations, are converted to a second format when stored in the Info Mart database.
- For multimedia, the start and end times are taken in seconds, which is the precision currently available from the data source. Although agent states, reasons, and sessions for agents handling multimedia interactions are calculated in milliseconds, the initial input has a one-second precision. The time values that result from calculations, including durations, are stored in the Info Mart database in seconds.
- The `SM_MEDIA_NEUTRAL_STATE_FACT` table is based on media-specific data in the `SM_RES_STATE_FACT` table and does not record subsecond states.

Important

The **populate-sm-<media type>-resource-activity** configuration options control which media types are populated in the summary resource tables. GCXI reports require these tables to be populated. Be aware that disabling population of voice data (in other words, setting `populate-sm-voice-resource-activity` to `false`) also affects population of `INTERACTION_RESOURCE_FACT` columns related to agent states—for example, ACW metrics.

The `SM_RES_SESSION_FACT` table

This table provides a summary of resource sessions by agent and media type. Genesys Info Mart 8.5 always populates this table.

Each row of this table summarizes the login session(s) of all DNs and places that are associated with an agent relative to a given media type. The grain of the fact is an accumulating snapshot that represents the duration of the summary session.

A summary session represents the contiguous duration that an agent resource is logged on for a given media type, irrespective of the number of DNs and/or queues to which the agent resource logs on.

- For voice, a summary session starts when an agent resource first logs on to any voice DN-queue combination. The session continues, irrespective of how many other voice DNs and/or queues the agent logs on to. The session ends when the agent resource logs off all voice DNs and queues.
- For multimedia, a session is first created when the agent resource adds a media type to their login session or logs onto a DN that supports this media. The login session continues until the agent resource removes the media type from the last login session that includes this media type, or logs out of the last DN that includes this media type.

Start and end dates and times are stored as facts in UTC time. Start and end date and times are also

stored as a dimension reference for DATE_TIME. Both active and completed sessions are populated.

Important

In some multimedia scenarios, an agent can process interactions for a particular media type without logging into the media (that is, without adding the media type to a place). In this scenario, Genesys Reporting does not see agent states related to the processing of interactions for the media type that is not added to the agent's place. Therefore, to ensure correct reporting, Genesys recommends that agents take care to add a media to a place before handling interactions of this media type.

The SM_RES_STATE_FACT table

Each row of this table describes a summarized agent resource state relative to a given media type. The grain of the fact is an accumulating snapshot that represents the duration of the summarized state. Genesys Info Mart 8.5 always populates this table.

A summary state represents the contiguous duration that an agent resource is logged on with a particular state for a given media type, irrespective of the number of DNs, places, and/or queues to which the agent resource logs on. The summary state is chosen from among the concurrent states of all DNs to which the agent is logged on, based on the configured state priority list. For multimedia, there are no DNs, so that the summarized state represents the state of the agent relative to the media type.

This table is sourced from IDB. The following states are recorded:

- Unknown (the agent is logged on, but the agent state is unknown)
- Busy
- Ready
- NotReady
- AfterCallWork (voice media only)

The start and end dates and times are stored as facts in UTC time. The start date and time are also stored as dimension references for the DATE_TIME dimension.

Whether the NotReady or AfterCallWork (voice media only) states can be interrupted by interactions that the agent initiates or receives while in these states depends on the configuration of the underlying ICON application.

Do-Not-Disturb is optionally factored into resource states in this table, based on the configuration of the underlying Switch object (see [Including Do-Not-Disturb data in summary tables](#)).

The SM_RES_STATE_REASON_FACT table

Each row of this table describes a summarized agent resource state reason and workmode relative to a given media type. The grain of the fact is an accumulating snapshot that represents the duration of the summarized state reason. Genesys Info Mart 8.5 always populates this table.

Important

You must set the ICON configuration option **gls-active-reason-codes** (in the **[callconcentrator]** section) to the mandatory value of `true`. This ensures that the `SM_RES_STATE_REASON_FACT` table is consistent in situations in which the reason code state ends after the transformation of the interval in which this reason code started. If this option is not set to `true`, the Genesys Info Mart configuration checker will log the problem and prevent any jobs from starting.

A summary state reason represents the contiguous duration for which an agent resource is in some state with a particular state reason for a given media type, irrespective of the number of DNAs and/or queues to which the agent resource logs on. A reason code state that is written into this table should have a highest priority among all concurrent agent states. This means the same state (without reason) will occur in the `SM_RES_STATE_FACT` table.

The `SM_RES_STATE_REASON_FACT` table is sourced from IDB. Reasons are recorded for the following states:

- Ready
- NotReady
- AfterCallWork (voice media only)

The start and end dates and times are stored as facts in UTC time. The start date and time are also stored as dimension references for the `DATE_TIME` dimension.

Genesys Info Mart does not provide a default reason for the NotReady state. Whether the NotReady or AfterCallWork (voice media only) states can be interrupted by interactions that the agent initiates or receives while in these states depends on the configuration of the underlying ICON application.

Do-Not-Disturb is optionally factored into summary state reasons with the predefined reason code key `DND_On` and no reason value, based on the configuration of the underlying Switch object (see [Including Do-Not-Disturb data in summary tables](#)). All reasons that are associated with the current highest priority state of the agent are recorded.

When multiple reason codes occur simultaneously for one agent, Genesys Info Mart chooses one of them to record in the `SM_RES_STATE_REASON_FACT` table based on the following considerations:

- A software reason code takes priority over hardware.
- If the keys are different, the higher-value string takes priority.
- If the keys are the same, the key with the higher string value (not the higher numeric value) takes priority (using case-insensitive alphabetical comparison).
- The `DND_on` reason takes the lowest priority with respect to other reason keys.
- Among two identical software reason codes with identical keys the priority is given to the state with the larger case-insensitive alphabetical reason code value.

Important

Reason code values are ranked alphabetically because ICON provides no data-type information to Genesys Info Mart that would identify whether the values are alphabetic, numerical, or mixed. As a result, some codes that occur in parallel may be ranked counterintuitively (5 > 45, for example)

When a reason-code state has a lower priority than some other concurrent agent state without a reason, this reason code state is not recorded in the `SM_RES_STATE_REASON_FACT` table.

Detailed information on all of the simultaneous reason codes is available in the `GIDB_G_AGENT_STATE_RC_V`, `GIDB_G_AGENT_STATE_RC_MM`, `GIDB_G_AGENT_STATE_A_V`, and `GIDB_G_AGENT_STATE_A_MM` tables. Note that the `GIDB_G_AGENT_STATE_RC_V` and `GIDB_G_AGENT_STATE_RC_MM` tables may contain multiple records for a single interaction, differing in their ending timestamp, if a reason-code state starts in one extract interval and ends in another extract interval.

The ignored-reason-codes configuration option enables you to filter out reason codes that are not useful for reporting, so that they do not interfere with the priority rankings. Any hardware or software reason code keys specified by this option will not appear in the `RESOURCE_STATE_REASON` and `SM_RES_STATE_REASON_FACT` tables. For example, by default, Genesys Info Mart will ignore the `INTERACTION_WORKSPACE` key that Genesys License Reporting Manager (LRM) attaches to interactions to indicate that Genesys Workspace Desktop Edition (formerly known as Interaction Workspace [IWS]) is being used.

The `SM_MEDIA_NEUTRAL_STATE_FACT` table

This table, which was introduced in release 8.5.002, is populated when the `populate-media-neutral-sm-facts` configuration option is set to `true`.

Each row of this table describes a summarized state of an agent resource across all media. Using media-specific `SM_RES_STATE_FACT` data as the source, the media-neutral state is the highest-priority state in effect for any of the agent's media for which Genesys Info Mart has been configured to populate summarized states. The priority is based on the configured state priority list.

A new row is inserted whenever there is the possibility that a new media-neutral summarized state was entered, such as when a summarized state begins in any media session for the resource, or when a summarized session for the resource ends. Because of the way the rows are populated, there may be multiple sequential rows for an agent with the same media-neutral state. There will never be more than one media-neutral state for an agent in the same second.

The `SM_MEDIA_NEUTRAL_STATE_FACT` table is populated up to the point where summarized state data is available for activity from both voice and multimedia data sources. Because evaluation of the highest media-neutral state can occur only after the media-specific summarized states have been transformed, population of the `SM_MEDIA_NEUTRAL_STATE_FACT` table is commonly one ETL cycle behind the `SM_RES_STATE_FACT` table.

The `STUCK_FLAG` indicates whether the highest-priority media-neutral state was determined based on data from only one of the data domains (voice or multimedia) — for example, because one of the

data domains was lagging significantly behind the other, or because there is only one data domain in the deployment.

The start and end dates and times are stored as facts in UTC time. The start date and time are also stored as dimension references for the DATE_TIME dimension. The start and end times result from calculation of the media-neutral summarized resource state and do not necessarily match the values in the underlying GIDB table(s) or the SM_RES_STATE_FACT table.

How is summarized data processed?

Genesys Info Mart combines information from ICON for the same agent and media type from the ICON GX_SESSION_ENDPOINT table to form summarized media type sessions.

For both voice and multimedia, Genesys Info Mart combines information for the same agent and media type from the GX_SESSION_ENDPOINT, G_LOGIN_SESSION, G_AGENT_STATE_HISTORY, G_AGENT_STATE_RC, G_AGENT_STATE_RC_A, and G_DND_HISTORY tables in IDB to form summarized states and reasons, which optionally have Do-Not-Disturb status factored into them.

In addition, for voice, a configurable state priority list is used to determine which DN's state is considered to be the winning state if the agent is logged on to more than one voice DN at a time.

Important

The timestamps for the start and end time in summarized tables may not match times in the IDB tables. END_TS in summarized tables means the beginning of the second by which the state has ended.

The difference in stored times becomes greater in complex scenarios with multiple simultaneous states for the same agent.

Moreover, the state sequence order may be incorrect in deployments with multiple Interaction Concentrator instances, because of time synchronization errors between the hosts.

Special considerations for long-duration sessions or states

Given usual contact-center organization and policies, Genesys reporting does not expect agent login sessions or states to be very long-lasting. However, in practice, agent sessions and states might last indefinitely — for example, if agents never log out.

From the point of view of Genesys Info Mart operations, long-lasting agent sessions and states negatively affect transformation performance. From the point of view of data quality, very long-lasting agent sessions or states can yield misleading reporting results — for example, if shift reporting (perhaps used for agent compensation) is based on unrealistic agent-activity data.

For these reasons, Genesys Info Mart provides functionality to apply timeouts to agent login sessions and states that exceed configurable maximum durations. By default, Genesys Info Mart allows a maximum duration of 24 hours for login sessions and 4 hours for each instance of an agent state within a login session. You can change the respective maximum durations by adjusting the settings for the max-session-duration-in-hours and max-state-duration options.

Detecting session inactivity

The timeout implementation enables Genesys Info Mart to detect when a session has gone inactive.

Genesys Info Mart will end the session when all states have ended, even if the end of the session has not been extracted and the session has not yet timed out. For example, if a state is timed out by **max-state-duration** and there are no other active states, then Genesys Info Mart deems the session to be inactive and terminates it.

Recognition of sessions that have gone inactive can provide more useful reporting on situations in which agents forget to log out. The smaller the value of **max-state-duration**, the sooner Genesys Info Mart will detect the session inactivity.

Handling resumed session activity

If a state transition occurs in a session that Genesys Info Mart previously timed out or ended because of inactivity, Genesys Info Mart creates a new session beginning with the new state. The new session continues until the first of the following occurs:

- All states in the new session have ended or have timed out.
- The new session times out after **max-session-duration-in-hours**.

Important

After a state has been timed out by **max-state-duration**, if there is a new resource state reason for that state, the reason will not be associated with any state or session:

- `SM_RES_STATE_REASON_FACT.SM_RES_SESSION_FACT_KEY = -1`
- `SM_RES_STATE_REASON_FACT.SM_RES_STATE_FACT_KEY = -1`

Special case with no contact center activity

In the rare event that there is no call or interaction activity in the contact center, agent states are updated only after some delay. You can minimize this delay by setting an appropriate value for an ICON configuration option, **dss-no-data-tout**. The default value is 300 seconds. As a result, by default there is a five-minute (300 second) delay before Info Mart sees that the agents have no interaction states. Genesys recommends that you reduce the delay to 60 seconds.

Obtaining uninterrupted voice AfterCallWork and NotReady data

To obtain uninterrupted ACW and NOT_READY data, set the **gls-enable-acw-busy** configuration option, which is located in the **[gts]** section on the **Annex** tab of the Switch configuration object, to 0 (the default setting is 1). This setting affects the agent model for parallel states.

Regardless of the configured priority list for parallel agent states in Genesys Info Mart, if `gls-enable-acw-busy=0` and an agent goes into the ACW or NOT_READY state and then makes some calls on the same switch during ACW or NOT_READY, ICON considers such calls to be a part of the ACW or NOT_READY state.

This means that, even if the default priority list is changed to have BUSY take first precedence over ACW and NOT_READY, but ICON is configured not to interrupt ACW and NOT_READY states, the BUSY state is not recorded when it happens during uninterrupted ACW and NOT_READY states.

Including Do-Not-Disturb data in summary tables

Do-Not-Disturb data is optionally factored into states and reasons in the summarized SM_RES_STATE_FACT and SM_RES_STATE_REASON_FACT tables for all media types. Inclusion of DND data is controlled by the `factor-dnd-into-sm-resource-states` configuration option, which is located in the **[gim-etl]** section on the **Annex** tab of each switch. The default setting is `true` for eServices/Multimedia switches and `false` for voice switches.

For eServices/Multimedia, Do-Not-Disturb is treated as a global NotReady for all media types to which an agent is logged on at a given place.

DND states are treated as NotReady with a reason that indicates DND on. The following table describes how DND state is calculated for the default state priority list (AfterCallWork, NOT_READY, BUSY, READY, UNKNOWN). The logic might be different for a user-configured state priority list, specified by the `sm-resource-state-priority` configuration option.

Calculating DND Status

Conditions	Resulting DND Status
DND is turned <i>on</i> and the declared state is currently Ready.	The resource is considered to be in a NotReady state with a reason that indicates DND On.
DND is turned <i>off</i> and the declared state was previously Ready.	The resource returns to Ready with whatever reasons were originally attached to the Ready request.
DND is turned <i>on</i> and the declared state is currently AfterCallWork.	The resource stays in the AfterCallWork state. If AfterCallWork ends before DND is turned back off, the resource becomes NotReady, and the reason is DND On. If DND is turned on and off during AfterCallWork, the resource state is never shown as NotReady. Note: AfterCallWork applies only to non-multimedia media types.
The resource is in NotReady state and DND is turned <i>on</i> or <i>off</i> .	Any NotReady reasons that are currently in effect are not interrupted. If an existing NotReady state had no reasons, a new NotReady reason state with the key DND On is added.
The resource is in Busy state and DND is turned <i>on</i> .	The resource immediately enters the NotReady state with DND On as the reason, and the Busy state is closed.

Technical Descriptors

Understanding when interaction resource facts (IRFs) and mediation segment facts (MSFs) are created can help you to determine which types of interaction resources and mediation segments to include in, or exclude from, your queries. The TECHNICAL_DESCRIPTOR dimension is a combination of attributes — resource roles, role reasons, technical results, and technical result reasons — that describe how interactions arrive at and depart from resources.

This page describes the technical descriptor combinations that are applicable for IRFs and MSFs for voice and multimedia. Some technical descriptors apply only to IRFs, some apply only to MSFs, and some apply to both. Similarly, some technical descriptors apply only to voice interactions, some apply only to multimedia interactions, and some apply to both. Whether a particular resource role or technical result applies to IRFs or MSFs for various media types depends on the type of resource.

After you understand the resource roles and technical results described on this page, go to:

- [Validated Voice Call Flows](#) for diagrams that depict the IRFs that result from typical voice interaction flows
- [Validated Multimedia Interaction Flows](#) for diagrams that depict the IRFs that result from typical multimedia interaction flows

Important

The TECHNICAL_DESCRIPTOR dimension table includes some combinations of resource roles, role reasons, technical results, and technical result reasons that Genesys Info Mart does not use. This page does not describe these combinations.

Resource Roles

The resource role of the interaction-handling or mediation resource depends on how the interaction arrives at the resource.

The [Resource Roles](#) table below describes the resource roles that Genesys Info Mart uses for resources that are the subjects of IRF or MSF records. Except where specified otherwise, all resource roles apply to both voice and multimedia interactions.

The number of potential resource roles for mediation resources is limited. For an ACD queue, virtual queue, multimedia interaction queue, or multimedia workbin, each row in the MSF table has a resource role of Received or ReceivedConsult.

For a list of the available combinations of resource roles with the other technical-descriptor attributes, see [Technical Descriptor Combinations](#).

Resource Roles and Role Reasons

Resource Role	Description	Comments
DivertedTo	Denotes an interaction that was delivered to the resource via an ACD queue.	Applies to: IRF (voice) A resource role of DivertedTo paired with a technical result of Conferenced indicates the initiator of a conference call.
InConference	Denotes that the IRF was created for a resource as the result of a conference call in which the resource joined the conference.	Applies to: IRF A resource role of InConference paired with a technical result of Conferenced indicates that, after joining the conference, the joining resource was the initiator of a subsequent conference.
Initiated	Denotes that the resource in the IRF row initiated either an internal interaction or an outbound interaction.	Applies to: IRF A resource role of Initiated paired with a technical result of Conferenced indicates that the resource initiated a call and was the initiator of a conference call.
InitiatedConsult	In the separate IRF record that is created when an agent or IVR initiates a consultation, denotes that the subject of the IRF initiated the consultation.	Applies to: IRF This resource role indicates that the subject of the IRF initiated a consultation, mute transfer, two-step transfer, or two-step conference to another resource.
Puller	Denotes that the resource pulled the multimedia interaction from an Interaction Queue or Interaction Workbin.	Applies to: IRF (multimedia)
Received	For IRFs, denotes that the resource received an inbound interaction without the benefit of prior distribution devices moving the call to it. This is typical for internal call types that are dialed directly to the resource. For MSFs, this resource role applies to all nonconsultation interactions that are received into a queue.	Applies to: IRF and MSF A resource role of Received paired with a technical result of Conferenced in the IRF context indicates the initiator of a conference call.
ReceivedConsult	Denotes that the IRF or MSF was created for a resource as the result of a consultation only (the resource did not receive a transfer, or was not joined into a conference). This enables counting of consultations that are received by a resource.	Applies to: IRF (voice and multimedia) and MSF (voice) <ul style="list-style-type: none"> A resource role of ReceivedConsult paired with a technical result of Conferenced represents the unlikely event that a resource receives a consultation, consults another resource, and then creates a conference call between the resources. This combination

Resource Role	Description	Comments
		<p>in the IRF context indicates the initiator of a conference call.</p> <ul style="list-style-type: none"> For MSF records, this resource role indicates that the interaction arrived in the mediation resource as the result of a consultation between contact center resources and was still in consultation when the interaction was diverted by the mediation resource.
ReceivedTransfer	<p>Denotes that the IRF was created as a result of the interaction being transferred to the IRF resource by a resource other than a nonself-service IVR, either directly or indirectly through an intermediate redirecting resource.</p>	<p>Applies to: IRF</p> <p>A resource role of ReceivedTransfer paired with a technical result of Conferenced indicates the initiator of a conference call.</p> <p>For voice interactions, a resource role of ReceivedTransfer paired with a role reason of IntroducedTransfer indicates that an interaction that would otherwise appear as a conference qualified as an introduced transfer, as defined by the introduced-transfer-threshold configuration option.</p>
RedirectedTo	<p>An interaction has been returned to the queue from which it was pulled.</p> <p>Note: An IRF is created for a queue only if the interaction ended in the queue — for example, if the technical result was CustomerAbandoned.</p>	<p>Applies to: IRF (multimedia)</p> <p>An interaction is redirected back to a queue if:</p> <ul style="list-style-type: none"> A routing strategy pulled the interaction from the queue and offered it to an agent, but the agent did not accept the invitation into the interaction. The interaction has been assigned to an agent for longer than the handling timeout that is configured in Interaction Server. The interaction has been assigned to a routing strategy for longer than the routing timeout that is configured in Interaction Server.
RoutedTo	<p>Denotes an interaction that was delivered to the resource via a routing point.</p>	<p>Applies to: IRF</p> <p>For voice interactions, a resource role of RoutedTo paired with a technical result of</p>

Resource Role	Description	Comments
		Conferenced indicates the initiator of a conference call.
Unknown	Genesys Info Mart does not have sufficient information to determine the resource role.	Applies to: IRF and MSF

Technical Results

The technical result and technical result reason of the IRF or MSF depend on how the interaction leaves the resource.

The **Technical Results** table below describes the technical results and technical result reasons that Genesys Info Mart uses for resources that are the subjects of IRF or MSF records. Except where specified otherwise, all technical results and technical result reasons apply to both voice and multimedia interactions.

For a list of the available combinations of technical results with the other technical-descriptor attributes, see **Technical Descriptor Combinations**.

Technical Results and Technical Result Reasons

Technical Result	Result Reason	Comment
Abandoned		Denotes that processing of the interaction by the resource did not complete normally.
	AbandonedWhileQueued	Applies to: IRF and MSF The interaction was abandoned while in the queue.
	Redirected	Applies to: IRF (voice) and MSF (voice) In the IRF context, processing of the voice interaction by the resource that is the subject of the IRF row was abandoned, and the interaction was redirected to another resource. In the MSF context, processing of the voice interaction by a target handling resource was abandoned, and the interaction was redirected to another resource.
	Rejected	Applies to: IRF (multimedia) and MSF (multimedia). A handling resource, which was an agent (or a place), was invited into the interaction but rejected the invitation. As a result, processing of the interaction was abandoned.

Technical Result	Result Reason	Comment
		<p>In the IRF context, the resource that rejected the invitation is the subject of the IRF record. In the MSF context, the resource that rejected the invitation is a target handling resource.</p>
	Revoked	<p>Applies to: IRF (multimedia) and MSF (multimedia).</p> <p>A handling resource, which was an agent (or a place), was invited into the interaction, but the invitation was revoked when the resource did not accept the invitation before the handling-timeout that is configured in Interaction Server. As a result, processing of the interaction was abandoned.</p> <p>In the IRF context, the resource that did not accept the invitation in time is the subject of the IRF record. In the MSF context, the resource that did not accept the invitation in time is a target handling resource.</p>
	Unspecified	<p>Applies to: IRF and MSF</p> <p>In MSF records with a resource role of ReceivedConsult:</p> <ul style="list-style-type: none"> For virtual queues, either the consultation was abandoned or a consultation was retrieved while in the virtual queue. For ACD queues, the consultation mediation attempt through this ACD queue was abandoned or retrieved while waiting for service.
AbnormalStop	<p>(Multimedia only)</p> <p>Denotes that the interaction was stopped by an entity (for example, Interaction Server or a Media Server) that was not a party to the interaction, in situations in which no other technical result applies. For example, AbnormalStop would not apply if the Media Server stops the interaction with a reason system name of Abandoned, because the technical result of CustomerAbandoned would apply to that scenario. The STOP_ACTION field in the last IRF for the interaction is 0.</p>	
	AbnormalStopWhileQueued	<p>Applies to: IRF and MSF</p> <p>The interaction was stopped while in the virtual queue, interaction queue, or workbin.</p>
	AbnormalStopWhileRinging	<p>Applies to: IRF</p>
	Unspecified	<p>Applies to: IRF and MSF</p>

Technical Result	Result Reason	Comment
Cleared	<p>Denotes that the interaction was cleared from a queue.</p> <p>Applies to: MSF</p>	
	DefaultRoutedByStrategy	<p>(Virtual queues only)</p> <p>The interaction was routed by URS to the default destination, as defined by the URS configuration options.</p>
	DefaultRoutedBySwitch	<p>(Voice virtual queues only)</p> <p>The switch default-routed the interaction.</p>
	PulledBack	<p>(Multimedia only)</p> <p>The routing strategy was unable to route the interaction successfully before the expiration of the routing-timeout that was configured in Interaction Server. As a result, the routing was considered to be a failure and the interaction was taken from the routing strategy and placed back into the interaction queue from which it came.</p>
	RoutedFromAnotherVQ	<p>(Virtual queues only)</p> <p>The interaction was added to this virtual queue as well as to a parallel virtual queue. It was routed from the parallel virtual queue to the target destination, and it was cleared from this virtual queue.</p>
	Stopped	<p>(Multimedia only)</p> <p>The interaction was stopped while in mediation, in situations in which neither CustomerAbandoned nor AbnormalStop applies.</p>
	StuckCall	<p>(Virtual queues only)</p> <p>An interaction that ICON identified as a stuck call was cleared from the virtual queue. (ICON determines that an interaction is stuck in a virtual queue if ICON received an event that indicates that the interaction entered the virtual queue, but ICON did not receive the event that indicates that the interaction exited the virtual queue, and URS has stopped sending status updates for that interaction.)</p> <p>Note: To calculate durations from virtual queue data accurately, Genesys recommends that rows that have this technical result and reason not be used.</p>
	Targets Cleared	<p>(Virtual queues only)</p> <p>The interaction was cleared from the</p>

Technical Result	Result Reason	Comment
		virtual queue by the URS strategy Clear Target function.
	Unspecified	<p>For virtual queues, usually indicates that the interaction was cleared from the virtual queue because no target was found.</p> <p>For ACD queues, usually indicates that the interaction was parallel queued and was not diverted from this ACD queue to another contact center resource.</p>
Completed	<p>Denotes that processing of the interaction by the resource completed normally.</p> <p>Applies to: IRF</p>	
	Archived	<p>(Multimedia only)</p> <p>The interaction was placed into an Interaction Queue that, based on the value of the completed-queues configuration option, Genesys Info Mart identifies as an archive queue for completed interactions.</p> <p>This Result Reason improves reporting in Genesys intelligent Workload Distribution (iWD) or other scenarios in which interactions are placed into “archiving” queues, instead of being terminated immediately after processing.</p>
	Canceled	<p>(Multimedia only)</p> <p>The interaction was placed into an Interaction Queue that, based on the value of the canceled-queues configuration option, Genesys Info Mart identifies as an archive queue for canceled interactions.</p> <p>This Result Reason improves reporting in iWD or other scenarios in which interactions are placed into “archiving” queues, instead of being terminated immediately after processing.</p>
	Unspecified	
Conferenced	<p>Denotes that the interaction resulted in a conference.</p> <p>See comments in the Resource Roles table, above, for the meaning of specific combinations of the Conferenced technical result with various resource roles.</p> <p>Applies to: IRF (voice)</p>	
	Unspecified	
CustomerAbandoned		Denotes that the customer initiated termination of the interaction, or the strategy initiated termination while the customer was present.

Technical Result	Result Reason	Comment
	<p>Note: In order for Genesys Info Mart to report that a multimedia interaction has been abandoned by the customer, the Media Server must operate in compatibility mode (with the Chat Server stop-abandoned-interaction configuration option set to true). For the reason for this requirement, see Abandoned in the discussion of Multimedia Stop Reason system names.</p>	
	AbandonedFromHold	<p>Applies to: IRF (voice)</p> <p>The handling resource placed the interaction on hold, and the customer abandoned the interaction.</p>
	AbandonedWhileQueued	<p>Applies to: IRF and MSF</p> <p>In MSF records, this technical result combination indicates that:</p> <ul style="list-style-type: none"> • For virtual queues, interaction queues, or workbins, the interaction was abandoned while in the mediation resource. • For ACD queues, the mediation attempt through this ACD queue was abandoned while waiting for service.
	AbandonedWhileRinging	Applies to: IRF
	AnsweredByOther	<p>Applies to: IRF (voice)</p> <p>For interactions that end in a nonself-service IVR, this technical result combination indicates that the customer abandoned the interaction before service could be provided.</p>
	Unspecified	Applies to: IRF and MSF
Deferred	<p>Denotes that the interaction was released because handling was deferred for some reason, not because it was abandoned by the customer. For example, the customer accepted a callback, instead of waiting on the line.</p> <p>Applies to: IRF</p>	
	CallbackAccepted	The customer accepted the callback offer.
DestinationBusy	<p>Denotes that the interaction did not reach the target resource because the destination was busy.</p> <p>Applies to: IRF (voice)</p>	
	Unspecified	
Diverted	Denotes that the mediation resource diverted the interaction to a target resource.	

Technical Result	Result Reason	Comment
	Applies to: MSF	
	AbandonedWhileRinging	<p>The interaction was abandoned before the target resource could answer it.</p> <p>For voice interactions, the target was a handling resource (Agent, IVR or ACD position DN) that had a talk count = 0, and re-route on no answer (RONA) did not occur.</p>
	AbnormalStopWhileRinging	<p>(Multimedia only)</p> <p>Before the target resource answered, the interaction was stopped by an entity that was not a party to the interaction (for example, by a Media Server).</p>
	AnsweredByAgent	<p>The target resource was an agent, and the agent answered the interaction.</p> <p>For voice interactions, the target resource was an agent who had a talk count > 0.</p>
	AnsweredByOther	<p>The target resource was not an agent, and it answered the interaction.</p> <p>For multimedia interactions, the target resource was a place, but no agent was logged in to that place.</p> <p>For voice interactions, the target was a resource, other than an agent, that had a talk count > 0 (typically an IVR or ACD Position DN).</p>
	Redirected	<p>The target resource did not answer the interaction; as a result, the interaction was routed to another resource.</p> <p>For voice interactions, the target was a resource that was re-routed on no answer (RONA'd) or that forwarded the interaction elsewhere.</p>
	Rejected	<p>(Multimedia only)</p> <p>The target resource was an agent (or a place). The agent (or place) was invited into the interaction, but the invitation was rejected. As a result, the interaction is placed back into the interaction queue from which it came.</p>
	Revoked	(Multimedia only)

Technical Result	Result Reason	Comment
		The target resource was an agent (or a place) that was invited into the interaction, but the invitation was not accepted before the delivering-timeout that was configured in Interaction Server. As a result, the interaction was placed back into the interaction queue from which it came.
	RoutedToOther	The target was a mediation resource that was not the subject of the IRF.
	RouteOnNoAnswer	(Voice only) The target resource was an agent; the call rang at the handling resource, was not answered, and was deflected to another resource.
	Unspecified	
Incomplete	Denotes that a callback media attempt did not complete successfully. Applies to: IRF	
	Unspecified	
OutboundStopped	An outbound interaction was created and stopped without being sent. Applies to: IRF (multimedia)	
	Unspecified	
Pulled	Denotes that the interaction was pulled from an Interaction Queue or Interaction Workbin. Applies to MSF (Multimedia)	
	Unspecified	
Redirected	Denotes that an interaction was redirected to another resource. Applies to: IRF	
	PulledBack	(Multimedia only) The agent did not handle the interaction before the handling-timeout that is configured in Interaction Server. As a result, the interaction was placed back into the interaction queue from which it came. When paired with a resource role of InConference, identifies the uncommon scenario in which an agent who was invited into a chat conference became the only remaining agent in the chat (in other words, the inviting agent left the chat), and then the remaining agent left the chat abnormally (for example, because the agent logged out while the

Technical Result	Result Reason	Comment
		interaction was still open, or the agent's desktop application terminated unexpectedly while the interaction was still open). As a result, Interaction Server pulled the interaction back from the agent and placed the interaction in a queue.
	Rejected	(Multimedia only) The target resource was an agent (or a place) that was invited into the interaction, but the invitation was rejected. As a result, the interaction was placed back into the interaction queue from which it came.
	Revoked	(Multimedia only) The target resource was an agent (or a place) that was invited into the interaction, but the invitation was not accepted before the delivering-timeout that was configured in Interaction Server. As a result, the interaction was placed back into the interaction queue from which it came.
	RouteOnNoAnswer	(Voice only) The interaction was diverted from an agent or IVR to another contact center resource as the result of a ring no answer. Starting with release 8.5.004, in scenarios when multiple attempts are made to route a call in deployments with the SIP Server configuration option divert-on-ringing set to false, a technical result of Redirected/RouteOnNoAnswer is reported for all but the last routing attempt, provided that SIP Server and ICON meet Genesys Info Mart requirements to support reporting on multiple routing attempts.
	Unspecified	For voice interactions, the interaction was diverted from an agent when forwarded to another resource, such as voice mail.
Transferred	Denotes that the resource completed a transfer of the interaction to another resource. Applies to: IRF	
	IntroducedTransfer	(Voice only) The transfer was actually accomplished via a short conference, during which the transferring agent introduced the customer to the receiving agent. The

Technical Result	Result Reason	Comment
		transferring agent (the subject of the IRF) then left the conference within the time limit specified by the introduced-transfer-threshold configuration option, while the receiving agent continued on the call.
	Unspecified	

Multimedia Stop Reason System Names

One of the reporting event attributes captured by eServices Interaction Server is the reason system name (`attr_reason_system_name`) associated with a request. The reason system name associated with a Stop Processing request is of particular significance and is captured by ICON in the `G_STOP_REASON` column of the `GM_L_USERDATA` table. There are certain Stop Processing reason names which are meaningful to Genesys Info Mart to correctly report the Technical Result:

Abandoned

In Media Server compatibility mode (described in the information on the Chat Server configuration option, `stop-abandoned-interaction`, in the eServices documentation), a chat interaction is stopped with a reason system name of Abandoned when it is abandoned by the customer. Genesys Info Mart uses this stop reason to determine if a chat interaction has been abandoned.

Sent

When an outbound-sending e-mail strategy sends an e-mail outside of the contact center, by convention, as illustrated in the Interaction Workflow Samples, the Strategy stops the outbound e-mail interaction with a reason system name of Sent. Genesys Info Mart relies upon this convention, and uses this stop reason to determine if an outbound e-mail was actually sent.

Normal

A stop reason of Normal may be used in a large variety of contexts, but there is only one scenario where its use affects Genesys Info Mart processing.

When an agent transfers a chat interaction to a Chat Transcript Queue, a Chat Transcript Strategy pulls the interaction from the queue, and decides whether or not to send an e-mail transcript of the chat interaction, based upon user data attached by Genesys Agent Desktop, and, by convention, as illustrated in the Interaction Workflow Samples, stops the chat interaction with a reason system name of Normal. Genesys Info Mart relies upon this convention to determine how to represent the action of the agent that transferred the chat interaction to the Chat Transcript Queue. In this case, the agent, who transferred the interaction to the Chat Transcript Queue, is not attempting to transfer the interaction to another resource, but instead has completed the chat activity, and the transfer action is to engage follow-up workflow processing.

Technical Descriptor Combinations

The TECHNICAL_DESCRIPTOR dimension is a composite of the resource role, role reason, technical result, and technical result reason attributes of a particular INTERACTION_RESOURCE_FACT (IRF) or MEDIATION_SEGMENT_FACT (MSF) record.

The table below summarizes the combinations of attributes that constitute the available technical descriptor dimensions, arranged initially in order of the TECHNICAL_DESCRIPTOR_KEY. Click a column name to sort the table by that column; reload the page to re-sort by TECHNICAL_DESCRIPTOR_KEY. New technical descriptors are added as required to support Genesys Info Mart features, and the table does not indicate in which release a technical descriptor combination was added.

For more information about the individual technical descriptor attributes, see [Resource Roles](#) and [Technical Results](#).

Important

The TECHNICAL_DESCRIPTOR dimension table includes some combinations of attributes that Genesys Info Mart does not use.

Technical Descriptor Key	Resource Role	Role Reason	Technical Result	Technical Result Reason
0	RECEIVED	UNSPECIFIED	COMPLETED	UNSPECIFIED
1	RECEIVED	UNSPECIFIED	ABANDONED	UNSPECIFIED
2	RECEIVED	UNSPECIFIED	TRANSFERRED	UNSPECIFIED
3	RECEIVED	UNSPECIFIED	ROUTED	UNSPECIFIED
4	RECEIVED	UNSPECIFIED	DIVERTED	UNSPECIFIED
5	RECEIVEDTRANSFER	UNSPECIFIED	COMPLETED	UNSPECIFIED
6	RECEIVEDTRANSFER	UNSPECIFIED	ABANDONED	UNSPECIFIED
7	RECEIVEDTRANSFER	UNSPECIFIED	TRANSFERRED	UNSPECIFIED
8	RECEIVEDTRANSFER	UNSPECIFIED	ROUTED	UNSPECIFIED
9	RECEIVEDTRANSFER	UNSPECIFIED	DIVERTED	UNSPECIFIED
10	RECEIVEDCONSULT	UNSPECIFIED	COMPLETED	UNSPECIFIED
11	RECEIVEDCONSULT	UNSPECIFIED	ABANDONED	UNSPECIFIED
12	RECEIVEDCONSULT	UNSPECIFIED	TRANSFERRED	UNSPECIFIED
13	RECEIVEDCONSULT	UNSPECIFIED	ROUTED	UNSPECIFIED
14	RECEIVEDCONSULT	UNSPECIFIED	DIVERTED	UNSPECIFIED
15	ROUTEDTO	UNSPECIFIED	COMPLETED	UNSPECIFIED
16	ROUTEDTO	UNSPECIFIED	ABANDONED	UNSPECIFIED
17	ROUTEDTO	UNSPECIFIED	TRANSFERRED	UNSPECIFIED
18	ROUTEDTO	UNSPECIFIED	ROUTED	UNSPECIFIED
19	ROUTEDTO	UNSPECIFIED	DIVERTED	UNSPECIFIED
20	DIVERTEDTO	UNSPECIFIED	COMPLETED	UNSPECIFIED
21	DIVERTEDTO	UNSPECIFIED	ABANDONED	UNSPECIFIED
22	DIVERTEDTO	UNSPECIFIED	TRANSFERRED	UNSPECIFIED
23	DIVERTEDTO	UNSPECIFIED	ROUTED	UNSPECIFIED

Technical Descriptor Key	Resource Role	Role Reason	Technical Result	Technical Result Reason
24	DIVERTEDTO	UNSPECIFIED	DIVERTED	UNSPECIFIED
25	INITIATEDCONSULT	UNSPECIFIED	COMPLETED	UNSPECIFIED
26	INITIATEDCONSULT	UNSPECIFIED	ABANDONED	UNSPECIFIED
27	INITIATEDCONSULT	UNSPECIFIED	TRANSFERRED	UNSPECIFIED
28	INITIATEDCONSULT	UNSPECIFIED	CONFERENCED	UNSPECIFIED
29	INCONFERENCE	UNSPECIFIED	COMPLETED	UNSPECIFIED
30	INCONFERENCE	UNSPECIFIED	ABANDONED	UNSPECIFIED
31	INCONFERENCE	UNSPECIFIED	TRANSFERRED	UNSPECIFIED
32	INITIATED	UNSPECIFIED	COMPLETED	UNSPECIFIED
33	INITIATED	UNSPECIFIED	ABANDONED	UNSPECIFIED
34	INITIATED	UNSPECIFIED	TRANSFERRED	UNSPECIFIED
35	RECEIVEDREQUEST	UNSPECIFIED	COMPLETED	UNSPECIFIED
36	RECEIVED	UNSPECIFIED	CUSTOMERABANDONED	ABANDONEDWHILEQUEUED
37	RECEIVED	UNSPECIFIED	CUSTOMERABANDONED	ABANDONEDFROMHOLD
38	RECEIVED	UNSPECIFIED	CUSTOMERABANDONED	ABANDONEDWHILERINGING
39	RECEIVEDTRANSFER	UNSPECIFIED	CUSTOMERABANDONED	ABANDONEDWHILEQUEUED
40	RECEIVEDTRANSFER	UNSPECIFIED	CUSTOMERABANDONED	ABANDONEDFROMHOLD
41	RECEIVEDTRANSFER	UNSPECIFIED	CUSTOMERABANDONED	ABANDONEDWHILERINGING
42	ROUTEDTO	UNSPECIFIED	CUSTOMERABANDONED	ABANDONEDWHILEQUEUED
43	ROUTEDTO	UNSPECIFIED	CUSTOMERABANDONED	ABANDONEDFROMHOLD
44	ROUTEDTO	UNSPECIFIED	CUSTOMERABANDONED	ABANDONEDWHILERINGING
45	DIVERTEDTO	UNSPECIFIED	CUSTOMERABANDONED	ABANDONEDWHILEQUEUED
46	DIVERTEDTO	UNSPECIFIED	CUSTOMERABANDONED	ABANDONEDFROMHOLD
47	DIVERTEDTO	UNSPECIFIED	CUSTOMERABANDONED	ABANDONEDWHILERINGING

Technical Descriptor Key	Resource Role	Role Reason	Technical Result	Technical Result Reason
48	INITIATED	UNSPECIFIED	DESTINATIONBUSY	UNSPECIFIED
49	RECEIVED	UNSPECIFIED	PULLED	UNSPECIFIED
50	RECEIVEDTRANSFER	UNSPECIFIED	PULLED	UNSPECIFIED
51	ROUTEDTO	UNSPECIFIED	PULLED	UNSPECIFIED
52	PULLER	UNSPECIFIED	COMPLETED	UNSPECIFIED
53	PULLER	UNSPECIFIED	TRANSFERRED	UNSPECIFIED
54	PULLER	UNSPECIFIED	ROUTED	UNSPECIFIED
55	PULLER	UNSPECIFIED	ABANDONED	UNSPECIFIED
56	PULLER	UNSPECIFIED	ABANDONED	ABANDONEDWHILEQUEUED
57	PULLER	UNSPECIFIED	CUSTOMERABANDONED	UNSPECIFIED
58	PULLER	UNSPECIFIED	CUSTOMERABANDONED	ABANDONEDWHILEQUEUED
59	PULLER	UNSPECIFIED	CUSTOMERABANDONED	ABANDONEDWHILERINGING
60	REDIRECTEDTO	UNSPECIFIED	PULLED	UNSPECIFIED
61	REDIRECTEDTO	UNSPECIFIED	ABANDONED	UNSPECIFIED
62	REDIRECTEDTO	UNSPECIFIED	CUSTOMERABANDONED	UNSPECIFIED
63	REDIRECTEDTO	UNSPECIFIED	CUSTOMERABANDONED	ABANDONEDWHILEQUEUED
64	RECEIVED	UNSPECIFIED	CLEARED	UNSPECIFIED
65	RECEIVED	UNSPECIFIED	CLEARED	STUCKCALL
66	UNKNOWN	UNSPECIFIED	NONE	UNSPECIFIED
67	INCONFERENCE	CONFERENCEINITIATOR	COMPLETED	UNSPECIFIED
68	INCONFERENCE	CONFERENCEJOINED	COMPLETED	UNSPECIFIED
69	INITIATED	UNSPECIFIED	ROUTED	UNSPECIFIED
70	RECEIVED	UNSPECIFIED	NONE	UNSPECIFIED
71	RECEIVEDTRANSFER	UNSPECIFIED	NONE	UNSPECIFIED

Technical Descriptor Key	Resource Role	Role Reason	Technical Result	Technical Result Reason
72	RECEIVEDCONSULT	UNSPECIFIED	NONE	UNSPECIFIED
73	ROUTEDTO	UNSPECIFIED	NONE	UNSPECIFIED
74	DIVERTEDTO	UNSPECIFIED	NONE	UNSPECIFIED
75	INITIATEDCONSULT	UNSPECIFIED	NONE	UNSPECIFIED
76	INCONFERENCE	UNSPECIFIED	NONE	UNSPECIFIED
77	INITIATED	UNSPECIFIED	NONE	UNSPECIFIED
78	RECEIVEDREQUEST	UNSPECIFIED	NONE	UNSPECIFIED
79	PULLER	UNSPECIFIED	NONE	UNSPECIFIED
80	REDIRECTEDTO	UNSPECIFIED	NONE	UNSPECIFIED
82	INCONFERENCE	CONFERENCEJOINED	ABANDONED	UNSPECIFIED
83	INCONFERENCE	UNSPECIFIED	CUSTOMERABANDONED	ABANDONEDWHILERINGING
84	INCONFERENCE	CONFERENCEJOINED	CUSTOMERABANDONED	ABANDONEDWHILERINGING
85	INITIATEDCONSULT	UNSPECIFIED	DESTINATIONBUSY	UNSPECIFIED
86	RECEIVED	UNSPECIFIED	DIVERTED	ANSWEREDBYAGENT
87	RECEIVED	UNSPECIFIED	DIVERTED	ANSWEREDBYOTHER
88	RECEIVED	UNSPECIFIED	DIVERTED	REDIRECTED
89	RECEIVED	UNSPECIFIED	DIVERTED	ABANDONEDWHILERINGING
90	RECEIVED	UNSPECIFIED	REDIRECTED	ROUTEONNOANSWER
91	ROUTEDTO	UNSPECIFIED	REDIRECTED	ROUTEONNOANSWER
92	DIVERTEDTO	UNSPECIFIED	REDIRECTED	ROUTEONNOANSWER
93	RECEIVEDCONSULT	UNSPECIFIED	REDIRECTED	ROUTEONNOANSWER
94	RECEIVEDTRANSFER	UNSPECIFIED	REDIRECTED	ROUTEONNOANSWER
95	INCONFERENCE	UNSPECIFIED	REDIRECTED	ROUTEONNOANSWER
96	RECEIVED	UNSPECIFIED	REDIRECTED	UNSPECIFIED

Technical Descriptor Key	Resource Role	Role Reason	Technical Result	Technical Result Reason
97	ROUTEDTO	UNSPECIFIED	REDIRECTED	UNSPECIFIED
98	DIVERTEDTO	UNSPECIFIED	REDIRECTED	UNSPECIFIED
99	RECEIVEDCONSULT	UNSPECIFIED	REDIRECTED	UNSPECIFIED
100	RECEIVEDTRANSFER	UNSPECIFIED	REDIRECTED	UNSPECIFIED
101	INCONFERENCE	UNSPECIFIED	REDIRECTED	UNSPECIFIED
102	RECEIVED	UNSPECIFIED	CLEARED	ROUTEDFROMANOTHERVQ
103	RECEIVED	UNSPECIFIED	CLEARED	DEFAULTROUTEDBYSTRATEGY
104	RECEIVED	UNSPECIFIED	CLEARED	DEFAULTROUTEDBYSWITCH
105	RECEIVED	UNSPECIFIED	CLEARED	TARGETSCLEARED
106	RECEIVED	UNSPECIFIED	CONFERENCED	UNSPECIFIED
107	RECEIVEDTRANSFER	UNSPECIFIED	CONFERENCED	UNSPECIFIED
108	ROUTEDTO	UNSPECIFIED	CONFERENCED	UNSPECIFIED
109	DIVERTEDTO	UNSPECIFIED	CONFERENCED	UNSPECIFIED
110	INCONFERENCE	UNSPECIFIED	CONFERENCED	UNSPECIFIED
111	RECEIVEDCONSULT	UNSPECIFIED	DIVERTED	ABANDONEDWHILERINGING
112	RECEIVEDCONSULT	UNSPECIFIED	DIVERTED	ANSWEREDBYAGENT
113	RECEIVEDCONSULT	UNSPECIFIED	DIVERTED	ANSWEREDBYOTHER
114	RECEIVEDCONSULT	UNSPECIFIED	DIVERTED	REDIRECTED
115	RECEIVEDCONSULT	UNSPECIFIED	DIVERTED	ROUTEONNOANSWER
116	ROUTEDTO	UNSPECIFIED	REDIRECTED	REJECTED
117	ROUTEDTO	UNSPECIFIED	REDIRECTED	REVOKED
118	RECEIVEDTRANSFER	UNSPECIFIED	ABANDONED	REJECTED
119	RECEIVEDCONSULT	UNSPECIFIED	ABANDONED	REJECTED
120	INCONFERENCE	UNSPECIFIED	ABANDONED	REJECTED

Technical Descriptor Key	Resource Role	Role Reason	Technical Result	Technical Result Reason
121	RECEIVEDTRANSFER	UNSPECIFIED	ABANDONED	REVOKED
122	RECEIVEDCONSULT	UNSPECIFIED	ABANDONED	REVOKED
123	INCONFERENCE	UNSPECIFIED	ABANDONED	REVOKED
124	INITIATED	UNSPECIFIED	REDIRECTED	PULLEDBACK
125	PULLER	UNSPECIFIED	REDIRECTED	PULLEDBACK
126	REDIRECTEDTO	PULLEDBACK	NONE	UNSPECIFIED
127	REDIRECTEDTO	PULLEDBACK	ABANDONED	UNSPECIFIED
128	REDIRECTEDTO	PULLEDBACK	CUSTOMERABANDONED	UNSPECIFIED
129	REDIRECTEDTO	PULLEDBACK	CUSTOMERABANDONED	ABANDONEDWHILEQUEUED
130	REDIRECTEDTO	PULLEDBACK	PULLED	UNSPECIFIED
131	RECEIVED	UNSPECIFIED	CUSTOMERABANDONED	ANSWEREDBYOTHER
132	RECEIVEDTRANSFER	UNSPECIFIED	CUSTOMERABANDONED	ANSWEREDBYOTHER
133	ROUTEDTO	UNSPECIFIED	CUSTOMERABANDONED	ANSWEREDBYOTHER
134	DIVERTEDTO	UNSPECIFIED	CUSTOMERABANDONED	ANSWEREDBYOTHER
135	RECEIVED	UNSPECIFIED	CLEARED	PULLEDBACK
136	RECEIVED	UNSPECIFIED	CLEARED	STOPPED
137	RECEIVED	UNSPECIFIED	DIVERTED	REVOKED
138	RECEIVED	UNSPECIFIED	DIVERTED	REJECTED
139	RECEIVED	UNSPECIFIED	DIVERTED	ROUTEDTOOTHER
140	INCONFERENCE	CONFERENCEJOINED	REDIRECTED	ROUTEONNOANSWER
141	INCONFERENCE	CONFERENCEJOINED	REDIRECTED	UNSPECIFIED
142	INITIATED	UNSPECIFIED	CONFERENCED	UNSPECIFIED
143	PULLER	UNSPECIFIED	PULLED	UNSPECIFIED
144	INCONFERENCE	CONFERENCEINITIATOR	TRANSFERRED	UNSPECIFIED

Technical Descriptor Key	Resource Role	Role Reason	Technical Result	Technical Result Reason
145	INCONFERENCE	CONFERENCEJOINED	TRANSFERRED	UNSPECIFIED
146	RECEIVEDTRANSFER	UNSPECIFIED	REDIRECTED	REJECTED
147	RECEIVEDTRANSFER	UNSPECIFIED	REDIRECTED	REVOKED
200	RECEIVEDCONSULT	UNSPECIFIED	CONFERENCED	UNSPECIFIED
201	INITIATED	UNSPECIFIED	CUSTOMERABANDONED	ABANDONEDFROMHOLD
202	UNKNOWN	UNSPECIFIED	ABANDONED	REVOKED
203	RECEIVEDTRANSFER	UNSPECIFIED	OUTBOUNDSTOPPED	UNSPECIFIED
204	ROUTEDTO	UNSPECIFIED	OUTBOUNDSTOPPED	UNSPECIFIED
205	INITIATED	UNSPECIFIED	OUTBOUNDSTOPPED	UNSPECIFIED
206	PULLER	UNSPECIFIED	OUTBOUNDSTOPPED	UNSPECIFIED
207	UNKNOWN	UNSPECIFIED	ABANDONED	ABANDONEDWHILEQUEUED
208	UNKNOWN	UNSPECIFIED	ABANDONED	REDIRECTED
209	UNKNOWN	UNSPECIFIED	ABANDONED	UNSPECIFIED
210	UNKNOWN	UNSPECIFIED	CLEARED	DEFAULTROUTEDBYSTRATEGY
211	UNKNOWN	UNSPECIFIED	CLEARED	DEFAULTROUTEDBYSWITCH
212	UNKNOWN	UNSPECIFIED	CLEARED	PULLEDBACK
213	UNKNOWN	UNSPECIFIED	CLEARED	ROUTEDFROMANOTHERVQ
214	UNKNOWN	UNSPECIFIED	CLEARED	STOPPED
215	UNKNOWN	UNSPECIFIED	CLEARED	STUCKCALL
216	UNKNOWN	UNSPECIFIED	CLEARED	TARGETSCLEARED
217	UNKNOWN	UNSPECIFIED	CLEARED	UNSPECIFIED
218	UNKNOWN	UNSPECIFIED	COMPLETED	UNSPECIFIED
219	UNKNOWN	UNSPECIFIED	CONFERENCED	UNSPECIFIED
220	UNKNOWN	UNSPECIFIED	CUSTOMERABANDONED	ABANDONEDFROMHOLD

Technical Descriptor Key	Resource Role	Role Reason	Technical Result	Technical Result Reason
221	UNKNOWN	UNSPECIFIED	CUSTOMERABANDONED	ABANDONEDWHILEQUEUED
222	UNKNOWN	UNSPECIFIED	CUSTOMERABANDONED	ABANDONEDWHILERINGING
223	UNKNOWN	UNSPECIFIED	CUSTOMERABANDONED	ANSWEREDBYOTHER
224	UNKNOWN	UNSPECIFIED	CUSTOMERABANDONED	UNSPECIFIED
225	UNKNOWN	UNSPECIFIED	DESTINATIONBUSY	UNSPECIFIED
226	UNKNOWN	UNSPECIFIED	DIVERTED	ABANDONEDWHILERINGING
227	UNKNOWN	UNSPECIFIED	DIVERTED	ANSWEREDBYAGENT
228	UNKNOWN	UNSPECIFIED	DIVERTED	ANSWEREDBYOTHER
229	UNKNOWN	UNSPECIFIED	DIVERTED	REDIRECTED
230	UNKNOWN	UNSPECIFIED	DIVERTED	REJECTED
231	UNKNOWN	UNSPECIFIED	DIVERTED	REVOKED
232	UNKNOWN	UNSPECIFIED	DIVERTED	ROUTEDTOOTHER
233	UNKNOWN	UNSPECIFIED	DIVERTED	ROUTEONNOANSWER
234	UNKNOWN	UNSPECIFIED	DIVERTED	UNSPECIFIED
235	UNKNOWN	UNSPECIFIED	OUTBOUNDSTOPPED	UNSPECIFIED
236	UNKNOWN	UNSPECIFIED	PULLED	UNSPECIFIED
237	UNKNOWN	UNSPECIFIED	REDIRECTED	PULLEDBACK
238	UNKNOWN	UNSPECIFIED	REDIRECTED	REJECTED
239	UNKNOWN	UNSPECIFIED	REDIRECTED	REVOKED
240	UNKNOWN	UNSPECIFIED	REDIRECTED	ROUTEONNOANSWER
241	UNKNOWN	UNSPECIFIED	REDIRECTED	UNSPECIFIED
242	UNKNOWN	UNSPECIFIED	ROUTED	UNSPECIFIED
243	UNKNOWN	UNSPECIFIED	TRANSFERRED	UNSPECIFIED
244	INCONFERENCE	UNSPECIFIED	CUSTOMERABANDONED	ABANDONEDWHILEQUEUED

Technical Descriptor Key	Resource Role	Role Reason	Technical Result	Technical Result Reason
245	RECEIVEDCONSULT	UNSPECIFIED	CLEARED	UNSPECIFIED
246	RECEIVEDCONSULT	UNSPECIFIED	CLEARED	STUCKCALL
247	RECEIVEDCONSULT	UNSPECIFIED	CLEARED	ROUTEDFROMANOTHERVQ
248	RECEIVEDCONSULT	UNSPECIFIED	CLEARED	DEFAULTROUTEDBYSTRATEGY
249	RECEIVEDCONSULT	UNSPECIFIED	CLEARED	DEFAULTROUTEDBYSWITCH
250	RECEIVEDCONSULT	UNSPECIFIED	CLEARED	TARGETSCLEARED
251	RECEIVEDCONSULT	UNSPECIFIED	CLEARED	PULLEDBACK
252	RECEIVEDCONSULT	UNSPECIFIED	CLEARED	STOPPED
253	UNKNOWN	UNSPECIFIED	ABNORMALSTOP	UNSPECIFIED
254	RECEIVED	UNSPECIFIED	ABNORMALSTOP	UNSPECIFIED
255	RECEIVEDTRANSFER	UNSPECIFIED	ABNORMALSTOP	UNSPECIFIED
256	ROUTEDTO	UNSPECIFIED	ABNORMALSTOP	UNSPECIFIED
257	INCONFERENCE	UNSPECIFIED	ABNORMALSTOP	UNSPECIFIED
258	INITIATED	UNSPECIFIED	ABNORMALSTOP	UNSPECIFIED
259	PULLER	UNSPECIFIED	ABNORMALSTOP	UNSPECIFIED
260	REDIRECTEDTO	UNSPECIFIED	ABNORMALSTOP	UNSPECIFIED
261	UNKNOWN	UNSPECIFIED	ABNORMALSTOP	ABNORMALSTOPWHILEQUEUED
262	UNKNOWN	UNSPECIFIED	ABNORMALSTOP	ABNORMALSTOPWHILERINGING
263	RECEIVED	UNSPECIFIED	ABNORMALSTOP	ABNORMALSTOPWHILEQUEUED
264	RECEIVED	UNSPECIFIED	DIVERTED	ABNORMALSTOPWHILERINGING
265	RECEIVEDTRANSFER	UNSPECIFIED	ABNORMALSTOP	ABNORMALSTOPWHILEQUEUED
266	RECEIVEDTRANSFER	UNSPECIFIED	ABNORMALSTOP	ABNORMALSTOPWHILERINGING
267	ROUTEDTO	UNSPECIFIED	ABNORMALSTOP	ABNORMALSTOPWHILEQUEUED
268	ROUTEDTO	UNSPECIFIED	ABNORMALSTOP	ABNORMALSTOPWHILERINGING

Technical Descriptor Key	Resource Role	Role Reason	Technical Result	Technical Result Reason
269	INCONFERENCE	UNSPECIFIED	ABNORMALSTOP	ABNORMALSTOPWHILERINGING
270	PULLER	UNSPECIFIED	ABNORMALSTOP	ABNORMALSTOPWHILEQUEUED
271	REDIRECTEDTO	UNSPECIFIED	ABNORMALSTOP	ABNORMALSTOPWHILEQUEUED
272	UNKNOWN	UNSPECIFIED	COMPLETED	ARCHIVED
273	RECEIVED	UNSPECIFIED	COMPLETED	ARCHIVED
274	RECEIVEDTRANSFER	UNSPECIFIED	COMPLETED	ARCHIVED
275	ROUTEDTO	UNSPECIFIED	COMPLETED	ARCHIVED
276	INITIATED	UNSPECIFIED	COMPLETED	ARCHIVED
277	PULLER	UNSPECIFIED	COMPLETED	ARCHIVED
278	REDIRECTEDTO	UNSPECIFIED	COMPLETED	ARCHIVED
279	UNKNOWN	UNSPECIFIED	COMPLETED	CANCELED
280	RECEIVED	UNSPECIFIED	COMPLETED	CANCELED
281	RECEIVEDTRANSFER	UNSPECIFIED	COMPLETED	CANCELED
282	ROUTEDTO	UNSPECIFIED	COMPLETED	CANCELED
283	INITIATED	UNSPECIFIED	COMPLETED	CANCELED
284	PULLER	UNSPECIFIED	COMPLETED	CANCELED
285	REDIRECTEDTO	UNSPECIFIED	COMPLETED	CANCELED
286	INCONFERENCE	UNSPECIFIED	REDIRECTED	PULLEDBACK
287	ROUTEDTO	UNSPECIFIED	REDIRECTED	PULLEDBACK
288	RECEIVEDTRANSFER	UNSPECIFIED	REDIRECTED	PULLEDBACK
289	RECEIVED	UNSPECIFIED	REDIRECTED	PULLEDBACK
290	REDIRECTEDTO	UNSPECIFIED	REDIRECTED	PULLEDBACK
291	RECEIVED	UNSPECIFIED	DEFERRED	CALLBACKACCEPTED
292	ROUTEDTO	UNSPECIFIED	DEFERRED	CALLBACKACCEPTED

Technical Descriptor Key	Resource Role	Role Reason	Technical Result	Technical Result Reason
293	DIVERTEDTO	UNSPECIFIED	DEFERRED	CALLBACKACCEPTED
294	RECEIVEDTRANSFER	UNSPECIFIED	DEFERRED	CALLBACKACCEPTED
295	REDIRECTEDTO	UNSPECIFIED	DEFERRED	CALLBACKACCEPTED
296	RECEIVED	UNSPECIFIED	INCOMPLETE	UNSPECIFIED
297	INITIATED	UNSPECIFIED	INCOMPLETE	UNSPECIFIED
298	RECEIVED	UNSPECIFIED	ABANDONED	ABANDONEDWHILEQUEUED
299	INCONFERENCE	UNSPECIFIED	REDIRECTED	REVOKED
300	INCONFERENCE	UNSPECIFIED	REDIRECTED	REJECTED
301	RECEIVEDCONSULT	UNSPECIFIED	REDIRECTED	REVOKED
302	RECEIVEDCONSULT	UNSPECIFIED	REDIRECTED	REJECTED
303	RECEIVED	UNSPECIFIED	TRANSFERRED	INTRODUCEDTRANSFER
304	RECEIVEDTRANSFER	UNSPECIFIED	TRANSFERRED	INTRODUCEDTRANSFER
305	RECEIVEDCONSULT	UNSPECIFIED	TRANSFERRED	INTRODUCEDTRANSFER
306	ROUTEDTO	UNSPECIFIED	TRANSFERRED	INTRODUCEDTRANSFER
307	DIVERTEDTO	UNSPECIFIED	TRANSFERRED	INTRODUCEDTRANSFER
308	INITIATEDCONSULT	UNSPECIFIED	TRANSFERRED	INTRODUCEDTRANSFER
309	INCONFERENCE	UNSPECIFIED	TRANSFERRED	INTRODUCEDTRANSFER
310	INITIATED	UNSPECIFIED	TRANSFERRED	INTRODUCEDTRANSFER
311	UNKNOWN	UNSPECIFIED	TRANSFERRED	INTRODUCEDTRANSFER
312	RECEIVEDTRANSFER	INTRODUCEDTRANSFER	COMPLETED	UNSPECIFIED
313	RECEIVEDTRANSFER	INTRODUCEDTRANSFER	ABANDONED	UNSPECIFIED
314	RECEIVEDTRANSFER	INTRODUCEDTRANSFER	ROUTED	UNSPECIFIED
315	RECEIVEDTRANSFER	INTRODUCEDTRANSFER	DIVERTED	UNSPECIFIED
316	RECEIVEDTRANSFER	INTRODUCEDTRANSFER	CUSTOMERABANDONED	ABANDONEDWHILEQUEUED

Technical Descriptor Key	Resource Role	Role Reason	Technical Result	Technical Result Reason
317	RECEIVEDTRANSFER	INTRODUCEDTRANSFER	CUSTOMERABANDONED	ABANDONEDFROMHOLD
318	RECEIVEDTRANSFER	INTRODUCEDTRANSFER	CUSTOMERABANDONED	ABANDONEDWHILERINGING
319	RECEIVEDTRANSFER	INTRODUCEDTRANSFER	NONE	UNSPECIFIED
320	RECEIVEDTRANSFER	INTRODUCEDTRANSFER	REDIRECTED	ROUTEONNOANSWER
321	RECEIVEDTRANSFER	INTRODUCEDTRANSFER	REDIRECTED	UNSPECIFIED
322	RECEIVEDTRANSFER	INTRODUCEDTRANSFER	CONFERENCED	UNSPECIFIED
323	RECEIVEDTRANSFER	INTRODUCEDTRANSFER	ABANDONED	REJECTED
324	RECEIVEDTRANSFER	INTRODUCEDTRANSFER	CUSTOMERABANDONED	ANSWEREDBYOTHER
325	RECEIVEDTRANSFER	INTRODUCEDTRANSFER	DEFERRED	CALLBACKACCEPTED
326	RECEIVEDTRANSFER	INTRODUCEDTRANSFER	TRANSFERRED	INTRODUCEDTRANSFER
327	RECEIVEDTRANSFER	INTRODUCEDTRANSFER	TRANSFERRED	UNSPECIFIED
328	INCONFERENCE	UNSPECIFIED	COMPLETED	ARCHIVED
329	INCONFERENCE	CONFERENCEINITIATOR	COMPLETED	ARCHIVED
330	INCONFERENCE	CONFERENCEJOINED	COMPLETED	ARCHIVED
331	INITIATEDCONSULT	UNSPECIFIED	COMPLETED	ARCHIVED
332	RECEIVEDCONSULT	UNSPECIFIED	COMPLETED	ARCHIVED
333	RECEIVEDREQUEST	UNSPECIFIED	COMPLETED	ARCHIVED
334	INCONFERENCE	UNSPECIFIED	COMPLETED	CANCELED
335	INCONFERENCE	CONFERENCEINITIATOR	COMPLETED	CANCELED
336	INCONFERENCE	CONFERENCEJOINED	COMPLETED	CANCELED
337	INITIATEDCONSULT	UNSPECIFIED	COMPLETED	CANCELED
338	RECEIVEDCONSULT	UNSPECIFIED	COMPLETED	CANCELED
339	RECEIVEDREQUEST	UNSPECIFIED	COMPLETED	CANCELED
340	ROUTEDTO	UNSPECIFIED	CUSTOMERABANDONED	UNSPECIFIED

Technical Descriptor Key	Resource Role	Role Reason	Technical Result	Technical Result Reason
341	INCONFERENCE	UNSPECIFIED	CUSTOMERABANDONED	ANSWEREDBYOTHER
342	INCONFERENCE	UNSPECIFIED	DIVERTED	UNSPECIFIED

Validated Voice Call Flows

This page summarizes the recognized, validated voice interactions that have been tested and that are supported by Genesys Info Mart. The validated interactions are premise-based flows that involve one or more of the deployed Genesys solutions.

The call flows that are described in this document are intended as examples that you can modify for your environment. However, Genesys does not guarantee results for modified interaction flows.

Important

Voice interactions that are generated by other supported Genesys solutions might yield call flows in Genesys Info Mart that do not directly translate to the call flows that are described in this document. Voice interactions that involve Genesys solutions and are not supported by Genesys Info Mart might yield unpredictable results.

The table below summarizes the validated call flows, organized according to the types of solution that might be deployed in your contact center.

Solution	Validated Call Flows
<p>Framework only</p> <p>Based on the dialed number, voice interactions that arrive at the switch are queued to an ACD queue that represents a requested skill, service type, or customer segment. Agents who are logged into the ACD queues handle the interactions.</p>	<p>[+] Inbound</p> <ul style="list-style-type: none"> • Inbound to agent via ACD queue • Inbound to agent directly • Mute transfer to ACD queue • Mute transfer to agent • Consult to agent via ACD queue, and then retrieve • Consult to agent, and then retrieve • Consult to agent via ACD queue, and then transfer • Consult to agent directly, and then transfer • Consult to agent via ACD queue, and then conference • Consult to agent directly, and then conference • Consult and transfer of a conference — Customer present throughout • Consult and transfer of a conference — Customer leaves • Consult and conference of a conference —

Solution	Validated Call Flows
	<p>Customer present throughout</p> <ul style="list-style-type: none"> • Consult and conference of a conference — Customer leaves • Introduced transfer <p>[+] Outbound</p> <ul style="list-style-type: none"> • Agent dials outbound call <p>[+] Internal</p> <ul style="list-style-type: none"> • Internal to agent via ACD queue • Internal to agent directly • Mute transfer to ACD queue • Mute transfer to agent • Consult to agent via ACD queue, and then retrieve • Consult to agent, and then retrieve • Consult to agent via ACD queue, and then transfer • Consult to agent, and then transfer • Consult to agent via ACD queue, and then conference • Consult to agent, and then conference
<p>IVR in front of switch</p> <p>Voice interactions arrive at an IVR that is visible to the IVR Server’s virtual T-Server. The focus of the IVR application can be either self-service or simple front-end identification and segmentation. If the IVR application cannot completely handle the voice interaction, the interaction can be transferred to an ACD queue behind the switch that represents a requested skill, service type, or customer segment. Agents logged in to the ACD queues handle the interactions.</p>	<ul style="list-style-type: none"> • Inbound to IVR DN • IVR transfer to ACD queue • IVR transfer to agent
<p>IVR behind switch</p> <p>Voice interactions that arrive at the switch are queued to an ACD queue, where the ACD positions are actually IVR DNs. The focus of the IVR application can be either self-service or simple front-end identification and segmentation. If the IVR application cannot completely handle the voice interaction, the interaction can be transferred to an ACD queue that represents a requested skill, service type, or customer segment. Agents who are logged in to the ACD queues handle the interactions.</p>	<ul style="list-style-type: none"> • Inbound to IVR via ACD queue • Inbound to IVR directly • Mute transfer to ACD queue • Mute transfer to agent

Solution	Validated Call Flows
<p>Universal Routing</p> <p>Voice interactions that arrive at the switch are delivered to a Routing Point. Universal Routing Server (URS) uses criteria such as ANI, DNIS, and the date and time of day to collect information and select an appropriate routing target. Basic targets are ACD queues and individual DNIS; more advanced targets are agent groups, place groups, and skill expressions.</p>	<ul style="list-style-type: none"> • Inbound interaction — Routing Point routes to ACD queue • Inbound interaction — Routing Point routes to agent
<p>Universal Routing assisted by IVR behind switch</p> <p>Voice interactions that arrive at the switch are queued to an ACD queue, where the ACD positions are actually IVR DNIS. The IVR application collects digits and information about the caller, and transfers the call to a Routing Point. Universal Routing uses the collected information to select an appropriate routing target. Basic targets are ACD queues and individual DNIS. More advanced targets are agent groups, place groups, and skill expressions.</p>	<ul style="list-style-type: none"> • Inbound call — Routing Point routes to ACD queue • Inbound call — Routing Point routes to agent • Inbound call to ACD and parallel IVR
<p>IVR in front of switch assisted by Universal Routing</p> <p>Voice interactions arrive at an IVR that is visible to the IVR Server's virtual T-Server. Through a Routing Point in the IVR Server's virtual T-Server, the IVR application invokes a Universal Routing strategy. Universal Routing instructs the IVR application to play applications or collect information. Universal Routing uses the collected information to return an appropriate target. The IVR application hook-flash transfers the call to that target.</p>	<ul style="list-style-type: none"> • Inbound interaction — IVR transfers to ACD queue • Inbound interaction — IVR transfers to agent
<p>IVR behind switch assisted by Universal Routing</p> <p>Voice interactions that arrive at the switch are queued to an ACD queue, where the ACD positions are actually IVR DNIS. Through a virtual routing point in the premise T-Server, the IVR application invokes a Universal Routing strategy. Universal Routing instructs the IVR application to play applications or collect information. Universal Routing uses the collected information to return an appropriate target. The IVR application mute transfers the call to that target.</p>	<ul style="list-style-type: none"> • Inbound call flow — IVR transfers to ACD queue • Inbound call flow — IVR transfers to agent

Diagram Conventions

The interaction flow diagrams in this guide use the following conventions:

- Dotted shading indicates customer wait time.
- Diagonal shading indicates customer handle time.

The following abbreviations are used for simplicity:

- IRF—Interaction Resource Fact
- MSF—Mediation Segment Fact
- SS IVR—Self-service IVR (considered to be a handling resource or resource of interest with regard to IRF data collection)
- nonSS IVR—Nonself-service IVR (considered not to be a handling resource or resource of interest with regard to IRF data collection)

Call Flow Legend

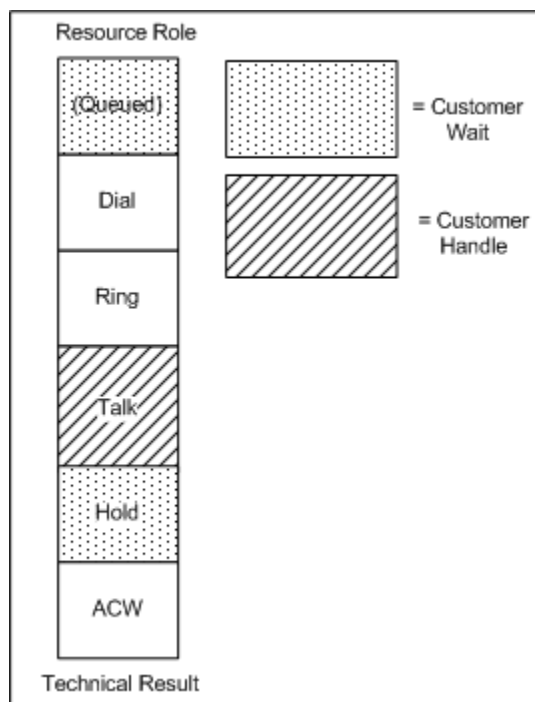

To show the interaction flow, the diagrams depict the media-specific states in sequence.

Sample call flow

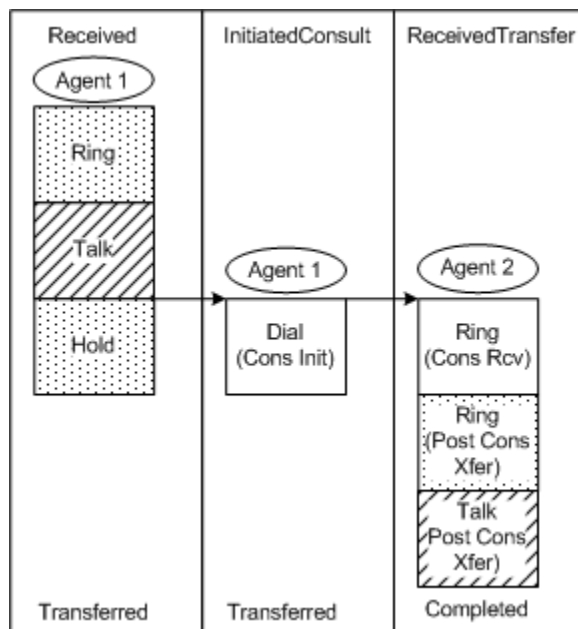

Notes on the interaction-flow diagrams

The diagrams represent the resources that participate in the interaction and their states.

- The circled resource in the diagram represents the resource that is the subject of the IRF record (the resource of interest).
- Vertical lines indicate separate IRF rows.
- The resources of interest are handling resources, which are the resources that have the greatest interest for reporting — agents, self-service IVRs, and DNs without an agent. Nonhandling resources include mediation resources such as queues, routing points, and nonself-service IVRs.
- The diagrams also show with which portion of the call each resource's state is associated (such as received consult, post-consult transfer, and post-consult conference). The resource role is shown above the IRF and the technical result below it.
- The accompanying descriptions summarize the resource role(s) and technical result(s) illustrated in the diagrams. All role reasons and technical result reasons are "Unspecified" except where indicated in square brackets.
- As described in the [Inbound to agent via ACD queue](#) call flow, all diagrams that illustrate the use of ACD queues apply to SIP Server hunt groups. For more information about how Genesys Info Mart represents hunt group activity, see [Hunt groups](#).

For notes about additional conventions for the multimedia interaction-flow diagrams, see [Multimedia diagram conventions](#).

Framework-Only Call Flows: Inbound

This page illustrates inbound call flows that Genesys Info Mart supports in deployments with a basic, Framework-only solution.

Based on the dialed number, voice interactions that arrive at the switch are queued to an ACD queue that represents a requested skill, service type, or customer segment. Agents who are logged into the ACD queues handle the interactions.

The following inbound call flows are supported:

- [Inbound to agent via ACD queue](#)
- [Inbound to agent directly](#)
- [Mute transfer to ACD queue](#)
- [Mute transfer to agent](#)
- [Consult to agent via ACD queue, and then retrieve](#)
- [Consult to agent, and then retrieve](#)
- [Consult to agent via ACD queue, and then transfer](#)
- [Consult to agent directly, and then transfer](#)
- [Consult to agent via ACD queue, and then conference](#)
- [Consult to agent directly, and then conference](#)
- [Consult and transfer of a conference — Customer present throughout](#)
- [Consult and transfer of a conference — Customer leaves](#)
- [Consult and conference of a conference — Customer present throughout](#)
- [Consult and conference of a conference — Customer leaves](#)
- [Introduced transfer](#)

For other supported call flows, see [Validated Voice Call Flows](#).

Important

Flows that start in a diagram under one of the other solutions can resume in another diagram under this solution (for example, if a voice interaction in Universal Routing is routed to an agent, and the agent performs a two-step transfer to another agent).

Inbound to agent via ACD queue

In this call topology, an inbound call is delivered to an agent via an ACD queue. The interaction arrives at the ACD queue, and the ACD queue diverts it to an agent.

This diagram and all other diagrams that include ACD queues also illustrate how Genesys Info Mart represents the call flow when the mediation resource is a SIP Server hunt group, instead of a regular ACD queue. In the case of a hunt group with parallel call distribution, Genesys Info Mart creates an IRF for the hunt group member that answers the call; the hunt group members that do not answer the call are not represented in the interaction. For more information about how Genesys Info Mart represents hunt group activity, see [Hunt groups](#).

Technical Descriptors illustrated:

- DivertedTo/Completed

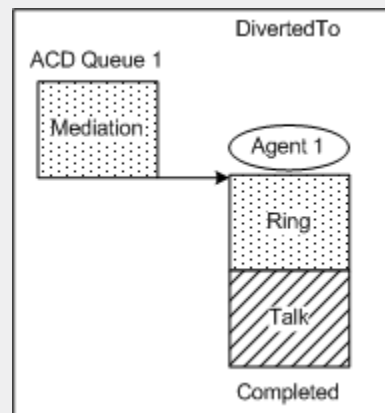

Inbound to agent directly

In this call topology, an inbound call is answered directly by an agent.

Technical Descriptors illustrated:

- Received/Completed

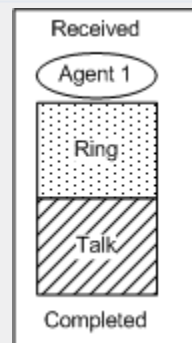

Mute transfer to ACD queue

In this call topology, an inbound call arrives at the ACD queue and is diverted to an agent. The agent then mute-transfers the call to another ACD queue.

There are three possible outcomes of a call that is mute-transferred to an ACD queue:

- The call is abandoned while it is in the second ACD queue.
- The call is abandoned while it is ringing at the second agent.
- The call is successfully transferred to the second agent.

Mute transfer to ACD queue — Abandoned in queue

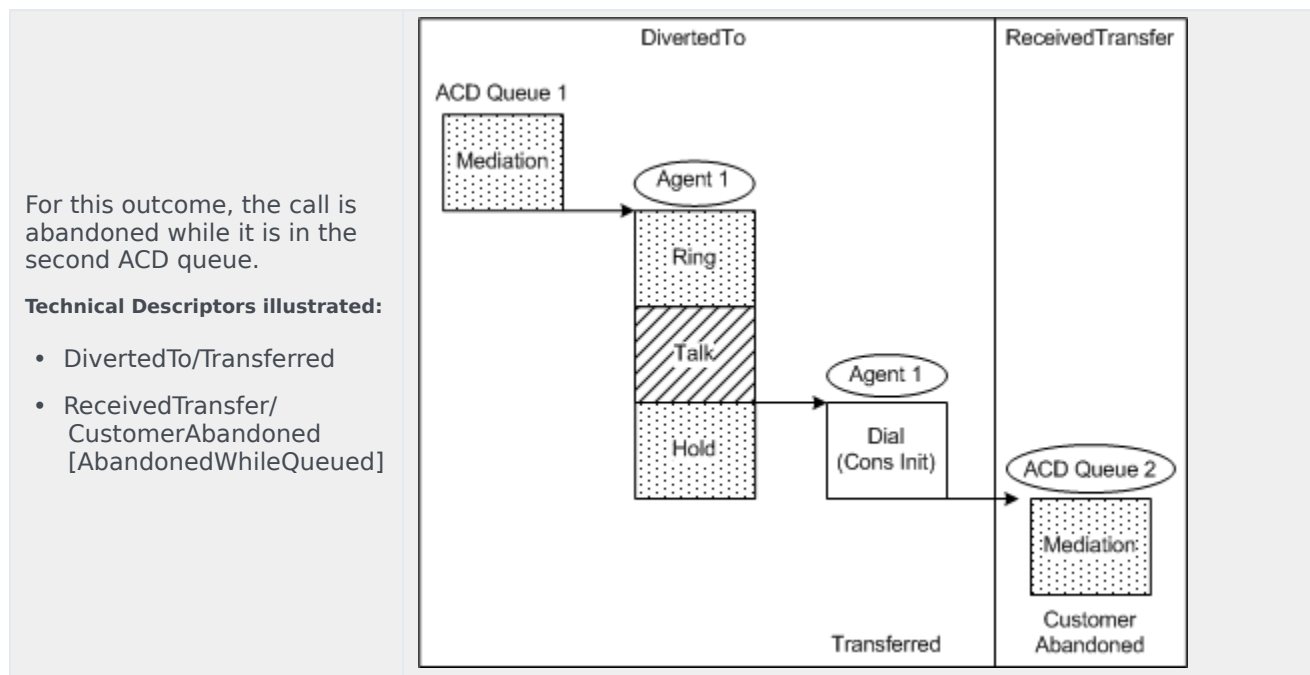

Mute transfer to ACD queue — Abandoned while ringing

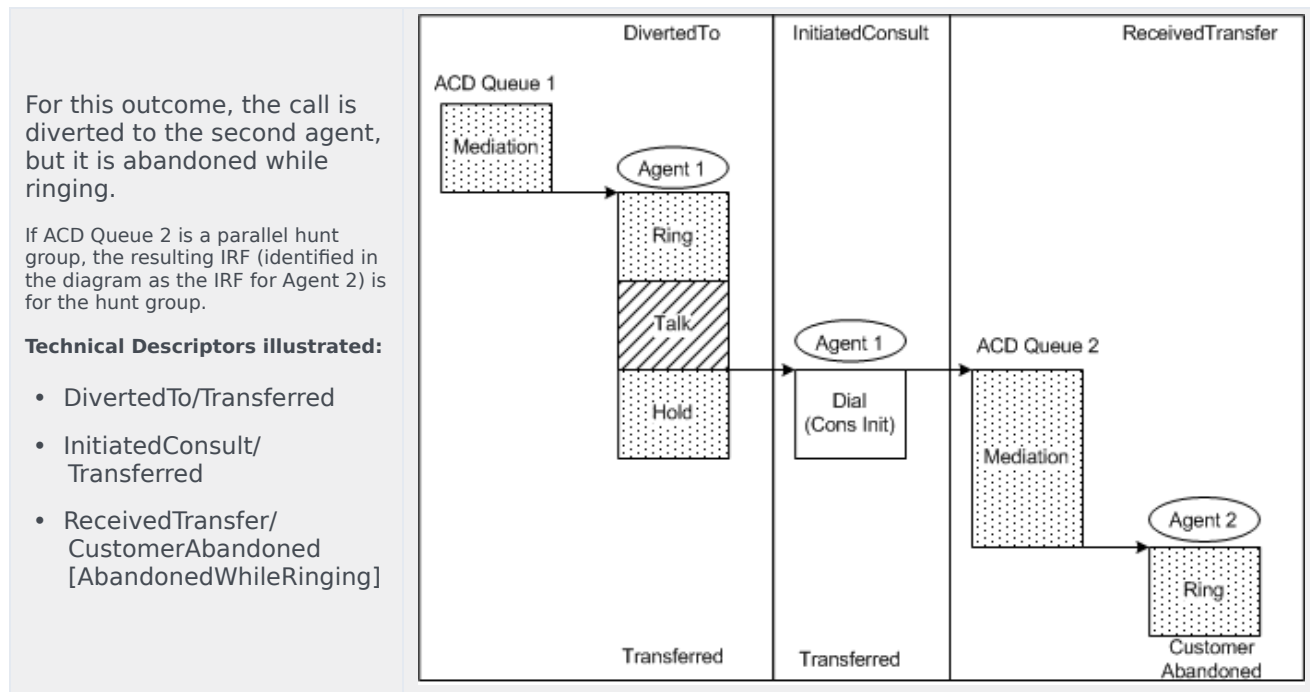

Mute transfer to ACD queue — Completed

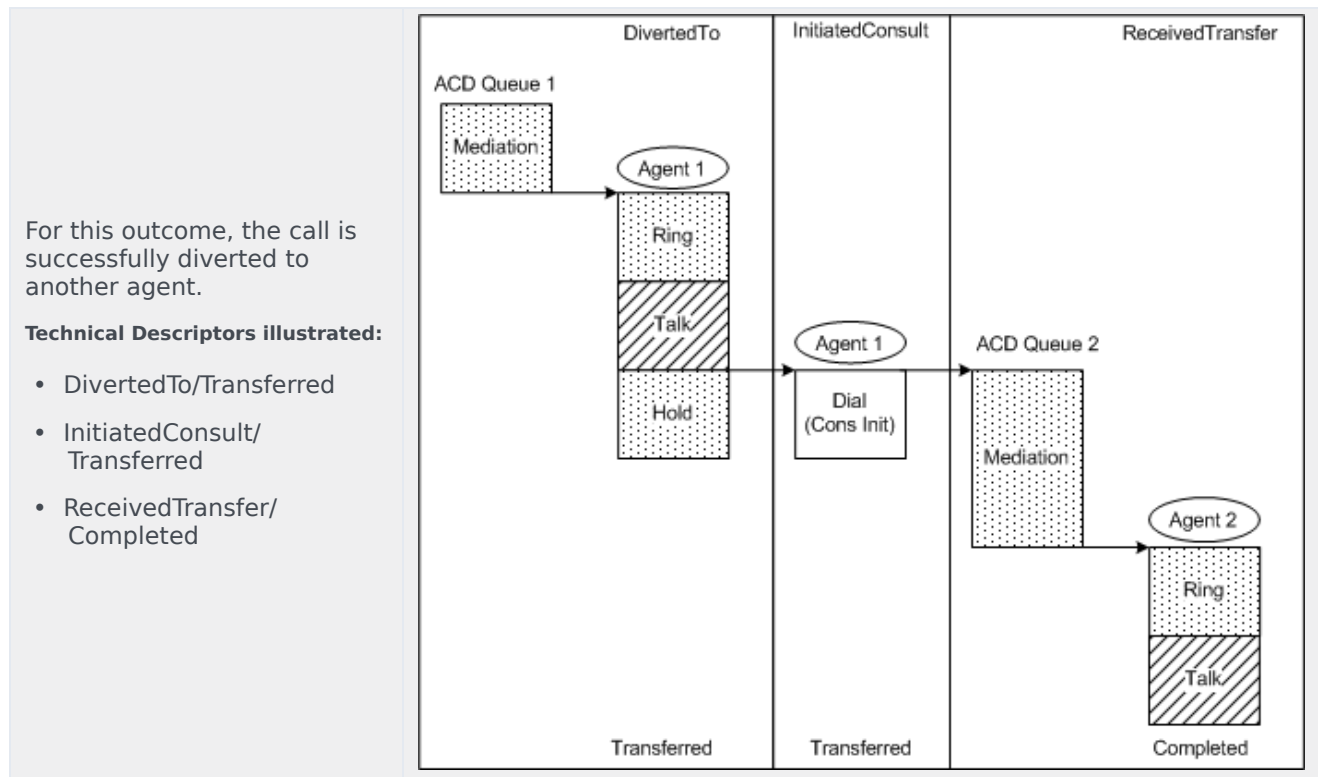

Mute transfer to agent

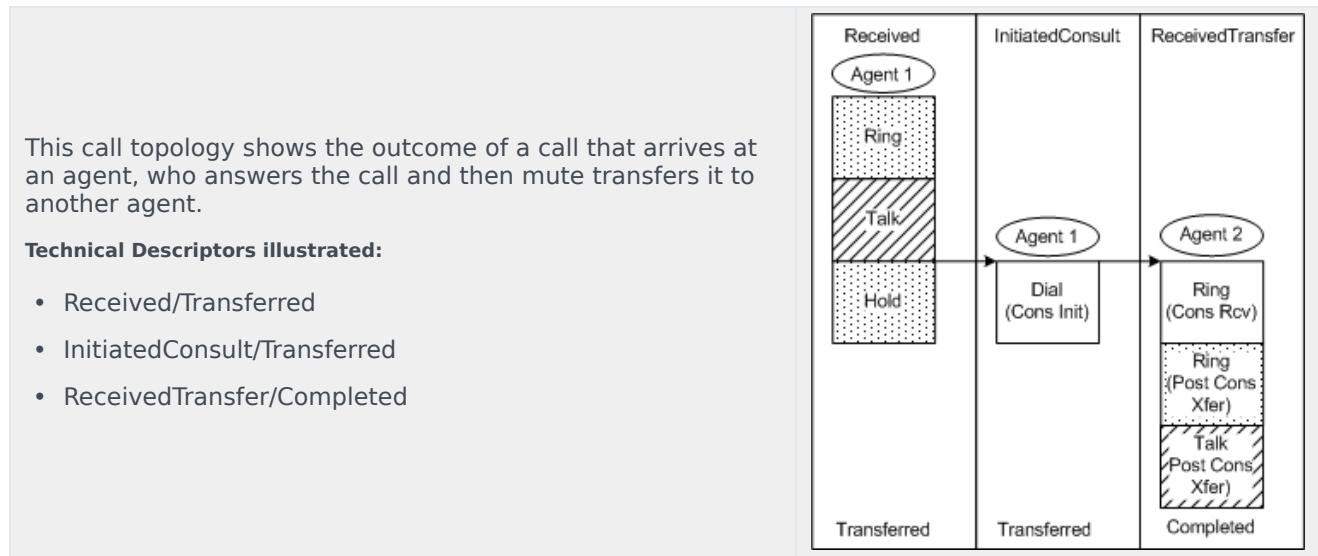

Consult to agent via ACD queue, and then retrieve

In this call topology, an inbound call arrives at the ACD queue and is diverted to an agent. The agent consults to another ACD queue, and the call is diverted to another agent. The consultation ends when the first agent retrieves the call.

There are three possible outcomes of a call that is retrieved after a consultation has been initiated:

- The call is retrieved while it is in the second queue.
- The call is retrieved while it is ringing at the second agent.
- The call is retrieved after the consultation is completed.

Consult to ACD queue — Abandoned in queue

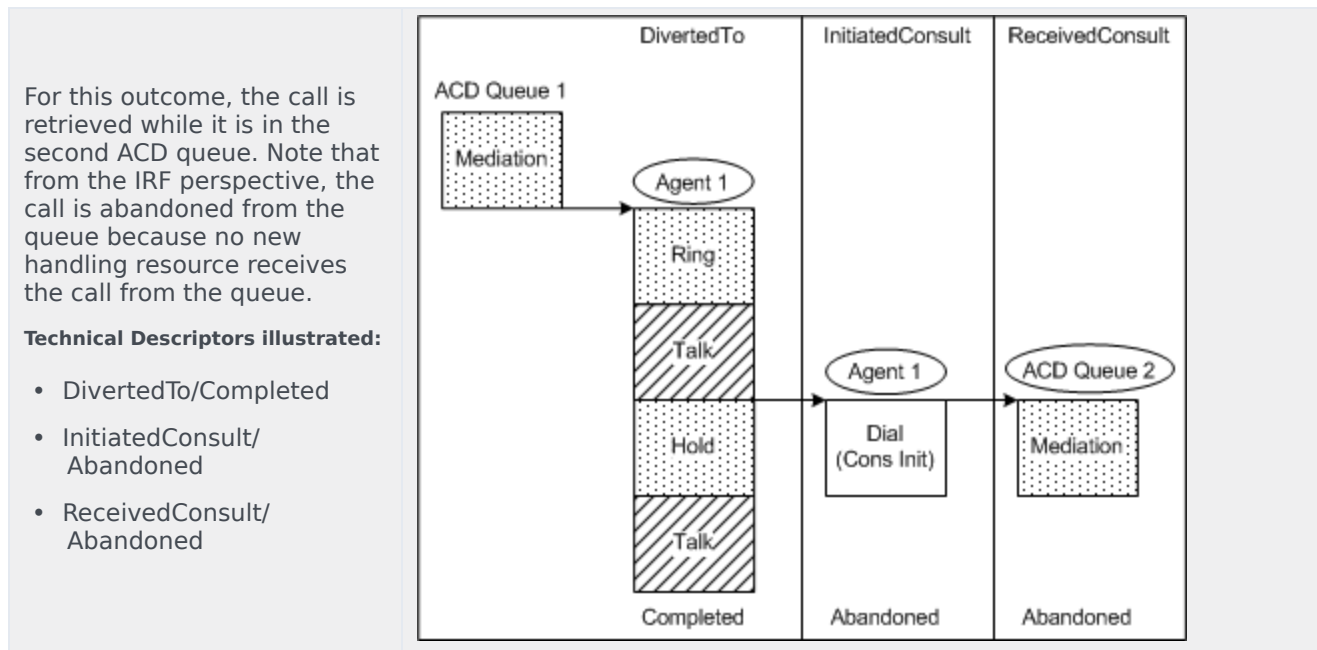

Consult to ACD queue — Abandoned while ringing

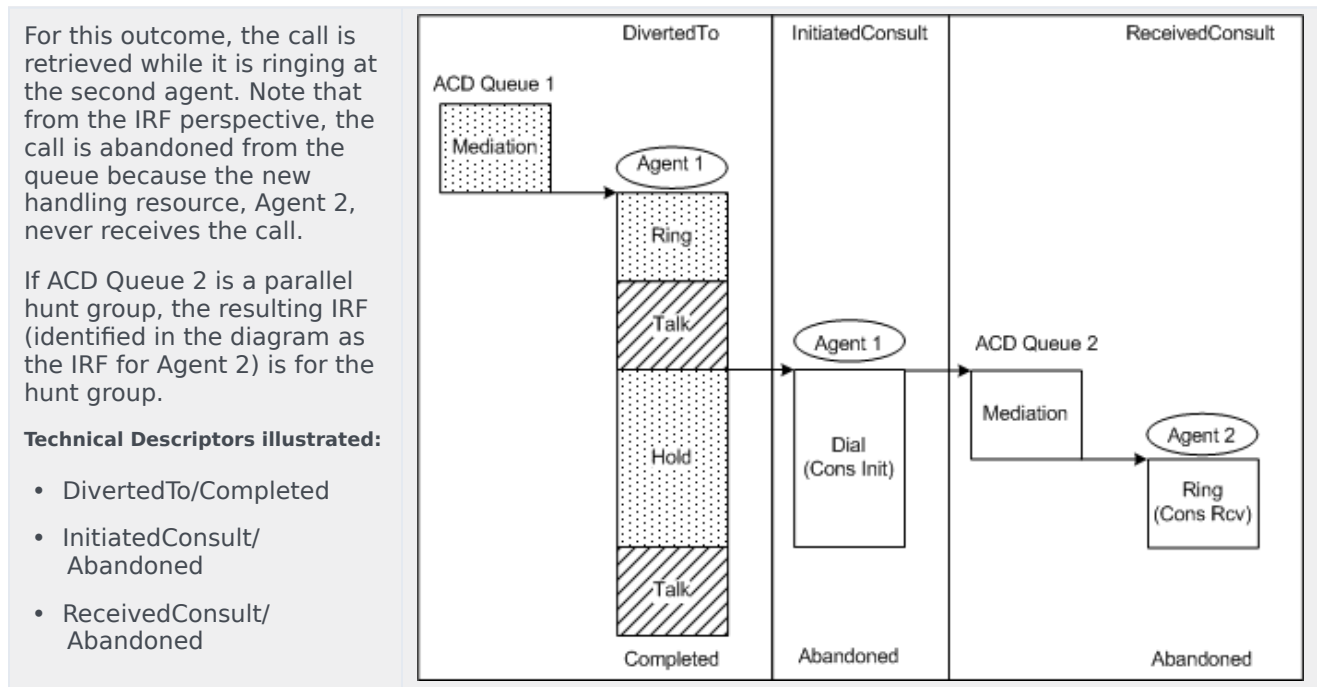

Consult to ACD queue — Completed

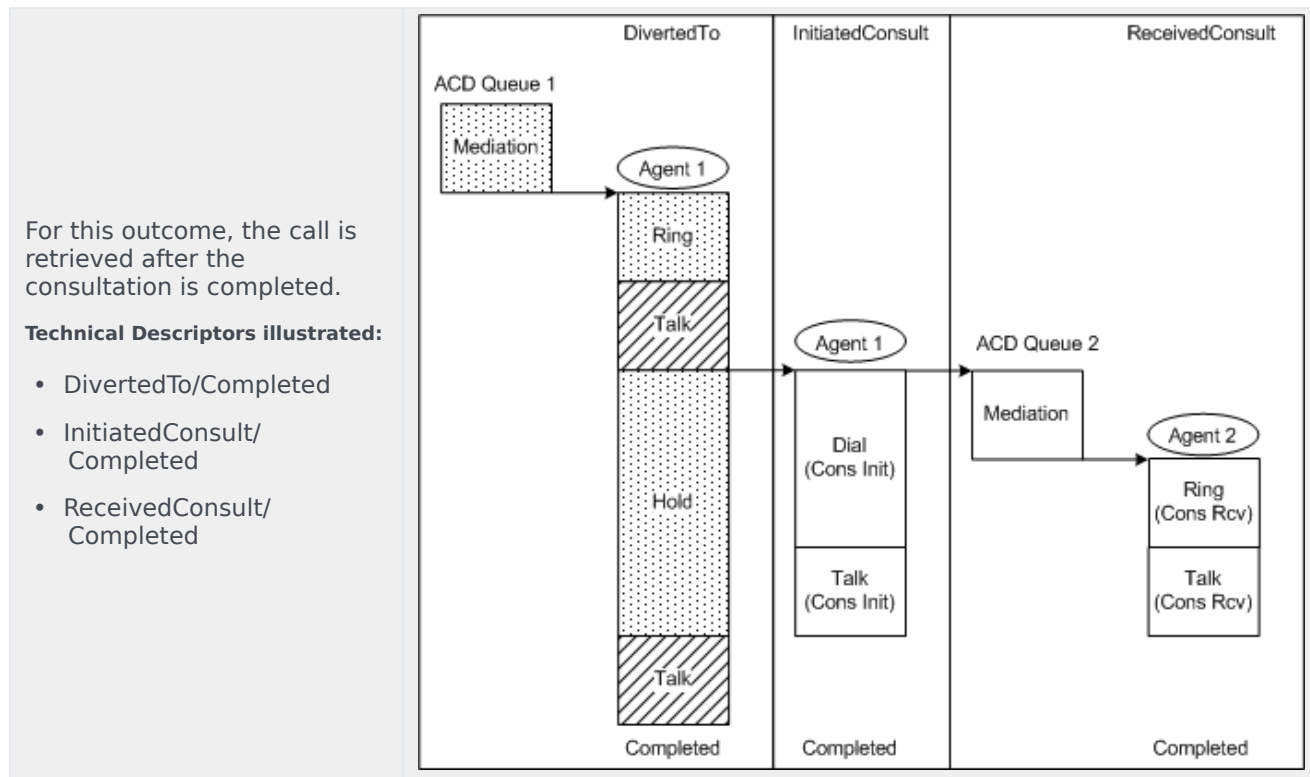

Consult to agent, and then retrieve

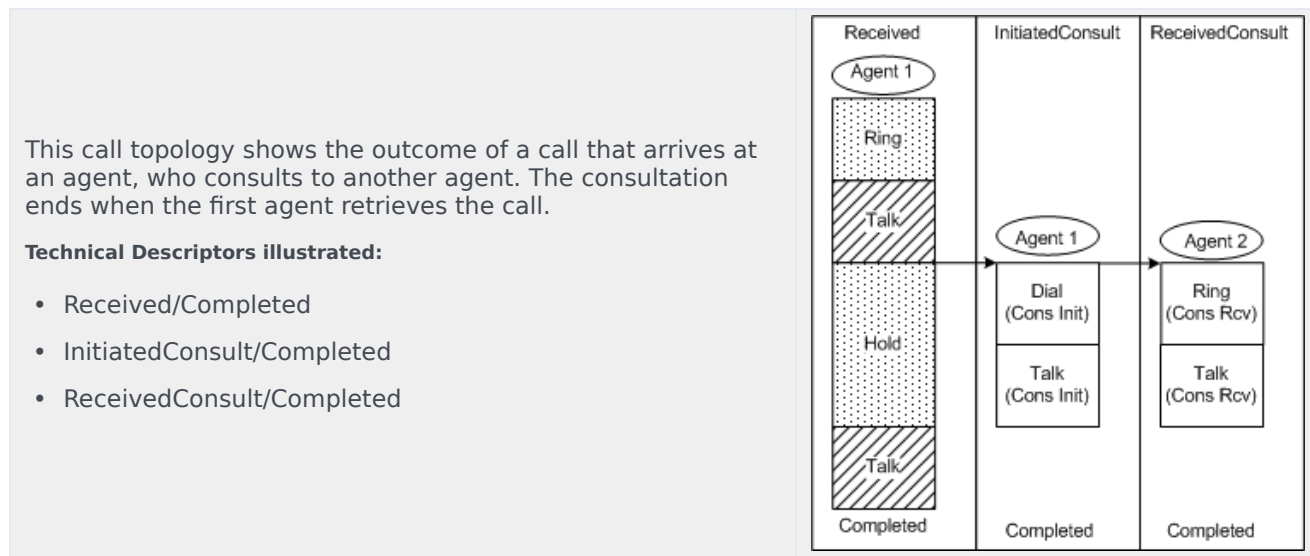

Consult to agent via ACD queue, and then transfer

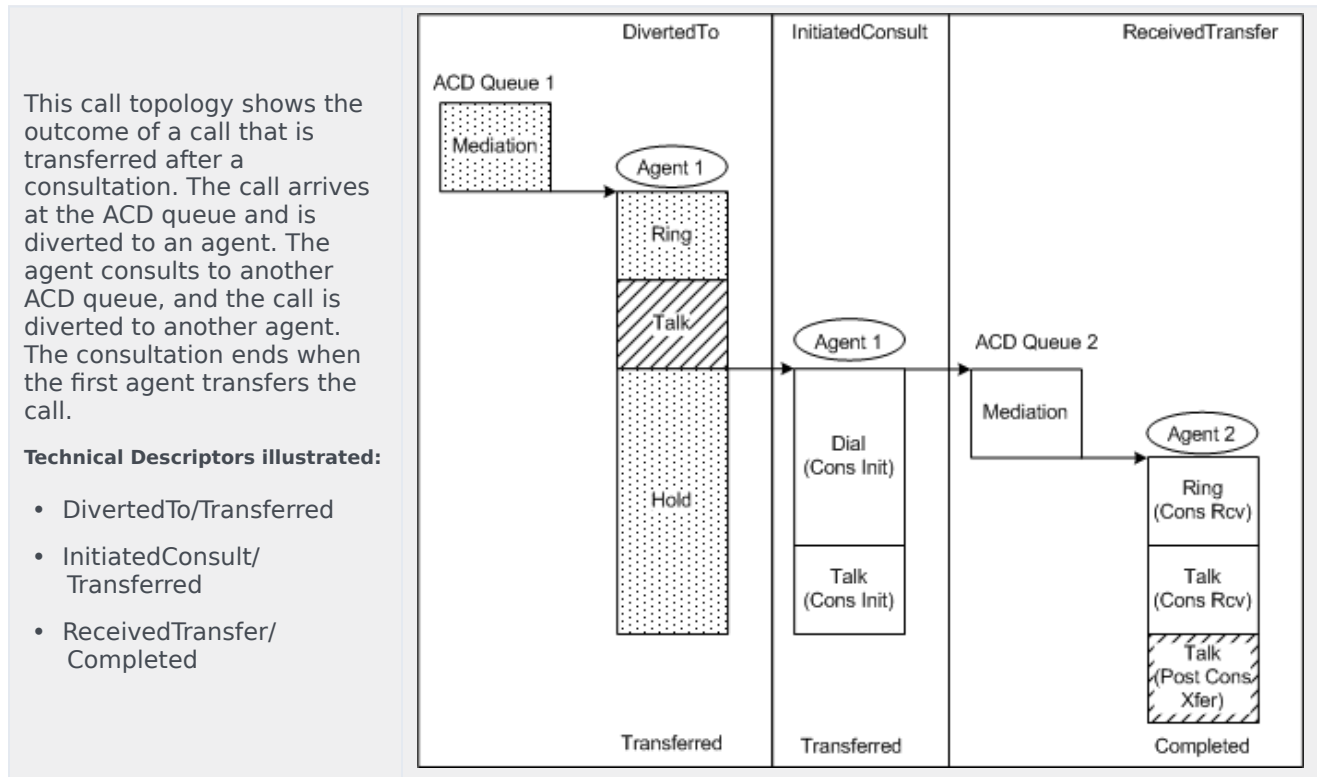

Consult to agent directly, and then transfer

This call topology shows the outcome of a call that is transferred after a consultation. The call arrives at an agent, who consults to another agent, and then transfers the call. The consultation ends when the first agent transfers the call.

Technical Descriptors illustrated:

- Received/Transferred
- InitiatedConsult/Transferred
- ReceivedTransfer/Completed

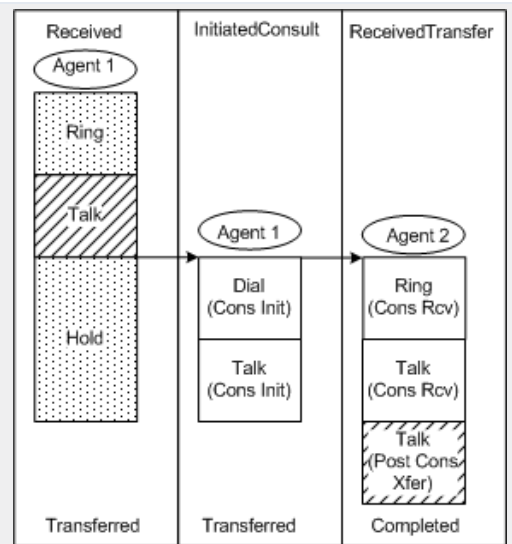

Consult to agent via ACD queue, and then conference

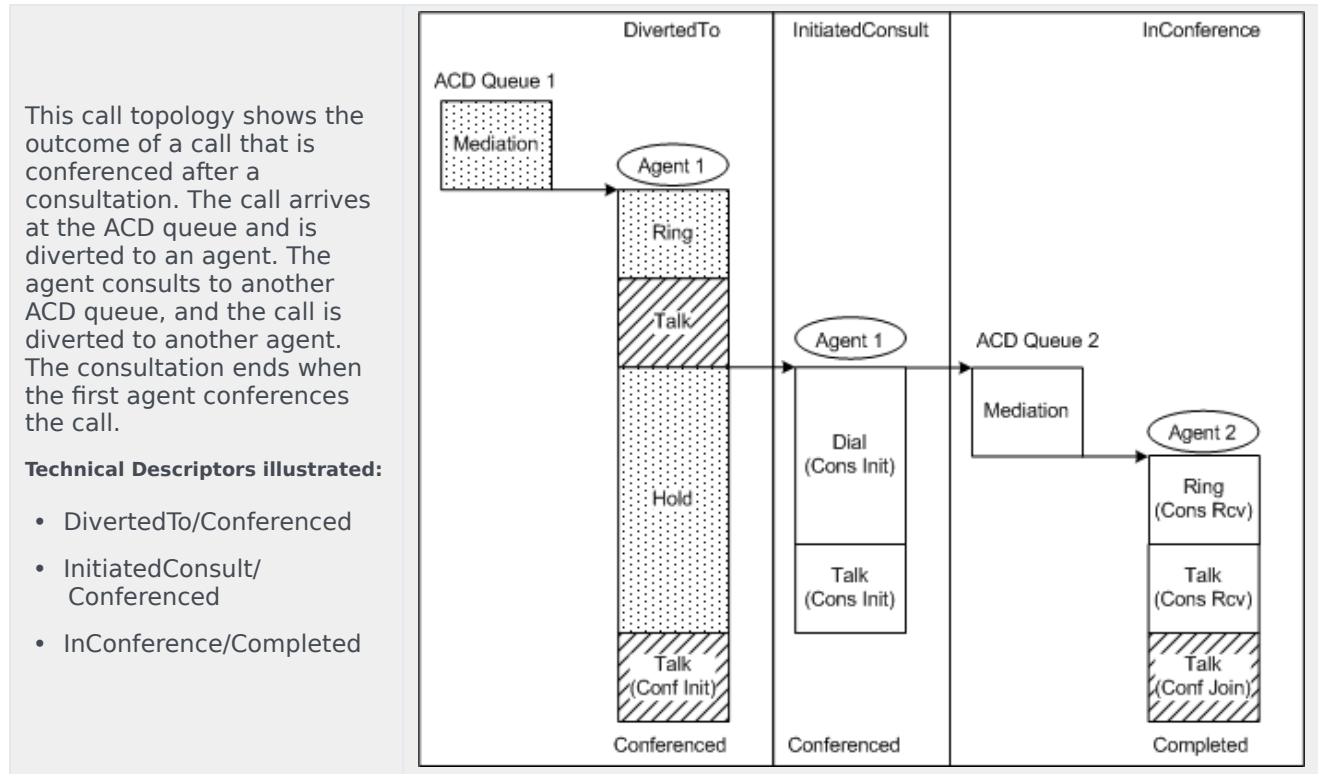

Consult to agent directly, and then conference

This call topology shows the outcome of a call that is conferenced after a consultation. The call arrives at an agent, who consults to another agent. The consultation ends when the first agent confernces the call.

Technical Descriptors illustrated:

- Received/Conferenced
- InitiatedConsult/Conferenced
- InConference/Completed

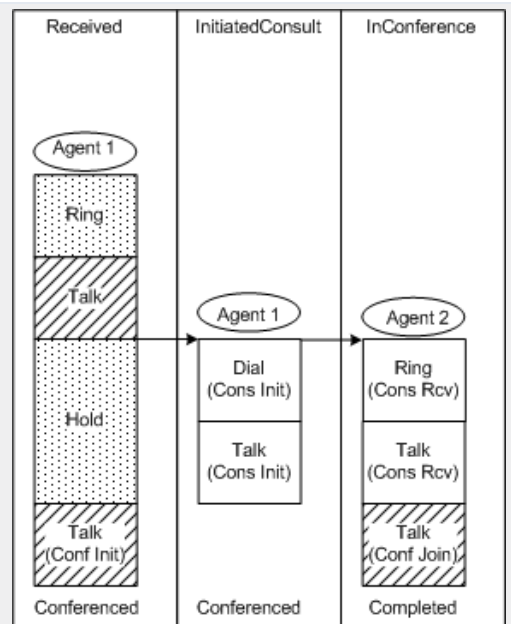

Consult and transfer of a conference – Customer present throughout

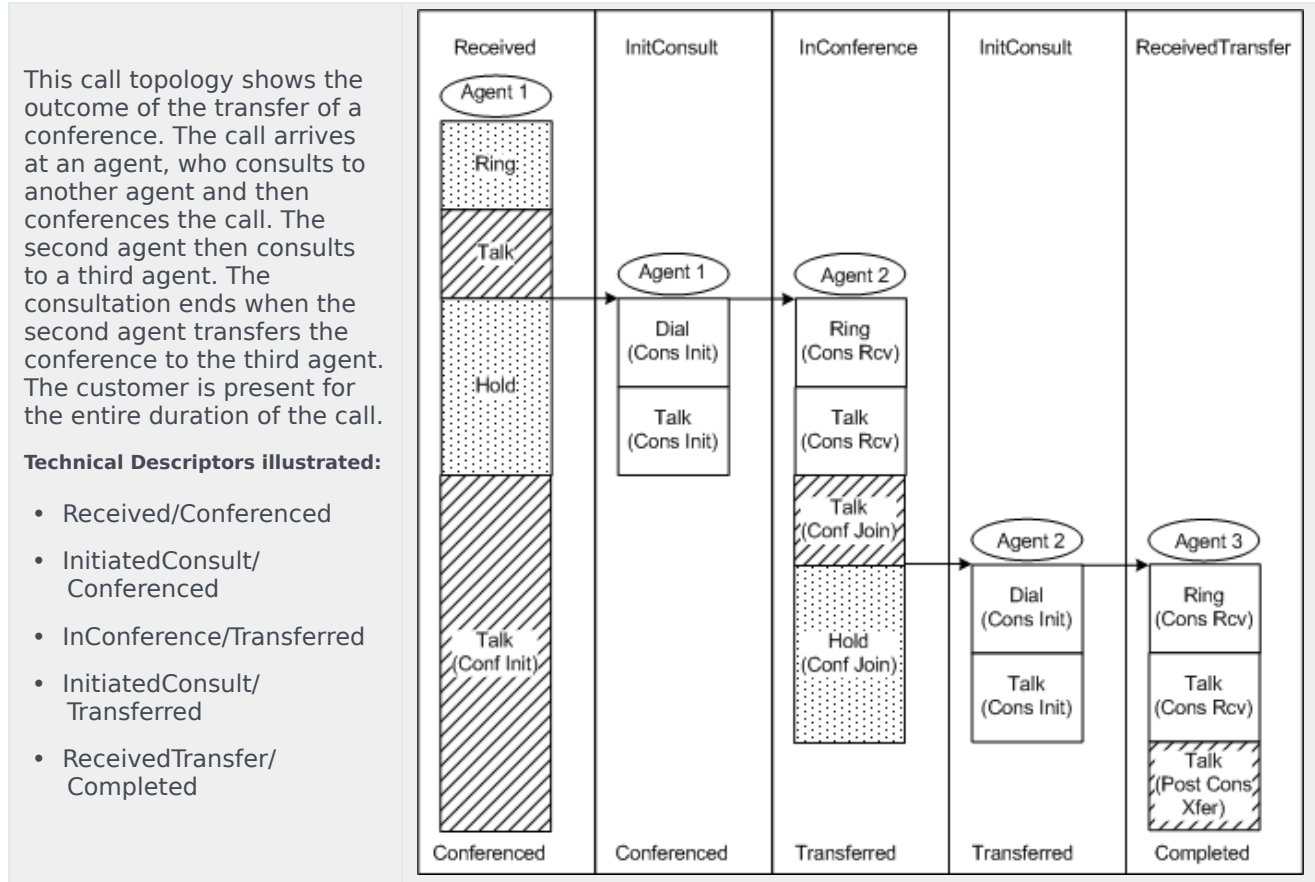

Consult and transfer of a conference — Customer leaves

This call topology shows the outcome of the transfer of a conference. The call arrives at an agent, who consults to another agent and then conferences the call. The second agent then consults to a third agent. The consultation ends when the second agent transfers the conference to the third agent. The customer leaves the call before the second agent consults the third agent.

Technical Descriptors illustrated:

- Received/Conferenced
- InitiatedConsult/Conferenced
- InConference/Transferred
- InitiatedConsult/Transferred
- ReceivedTransfer/Completed

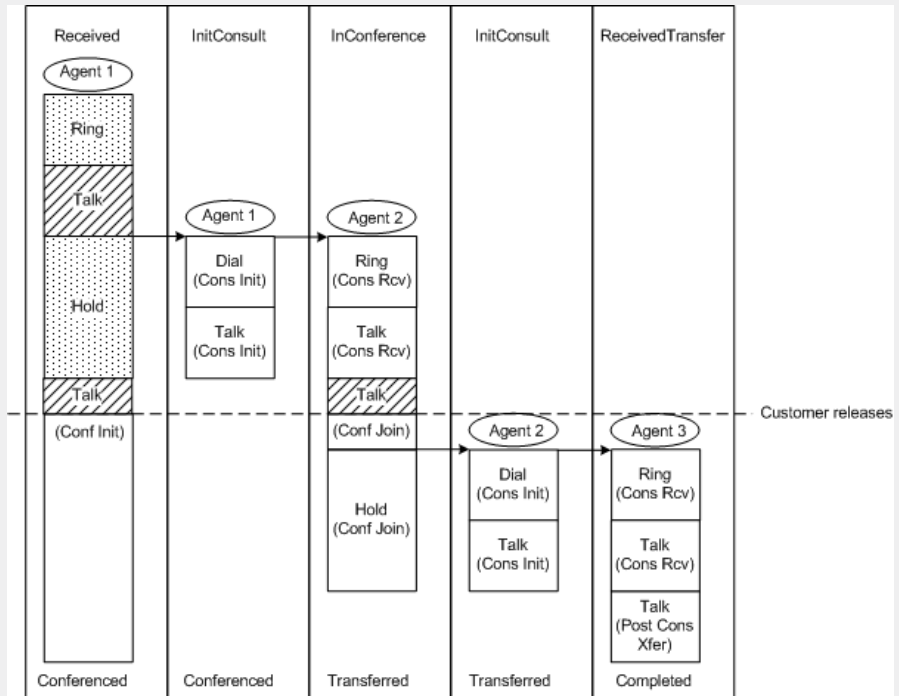

Consult and conference of a conference — Customer present throughout

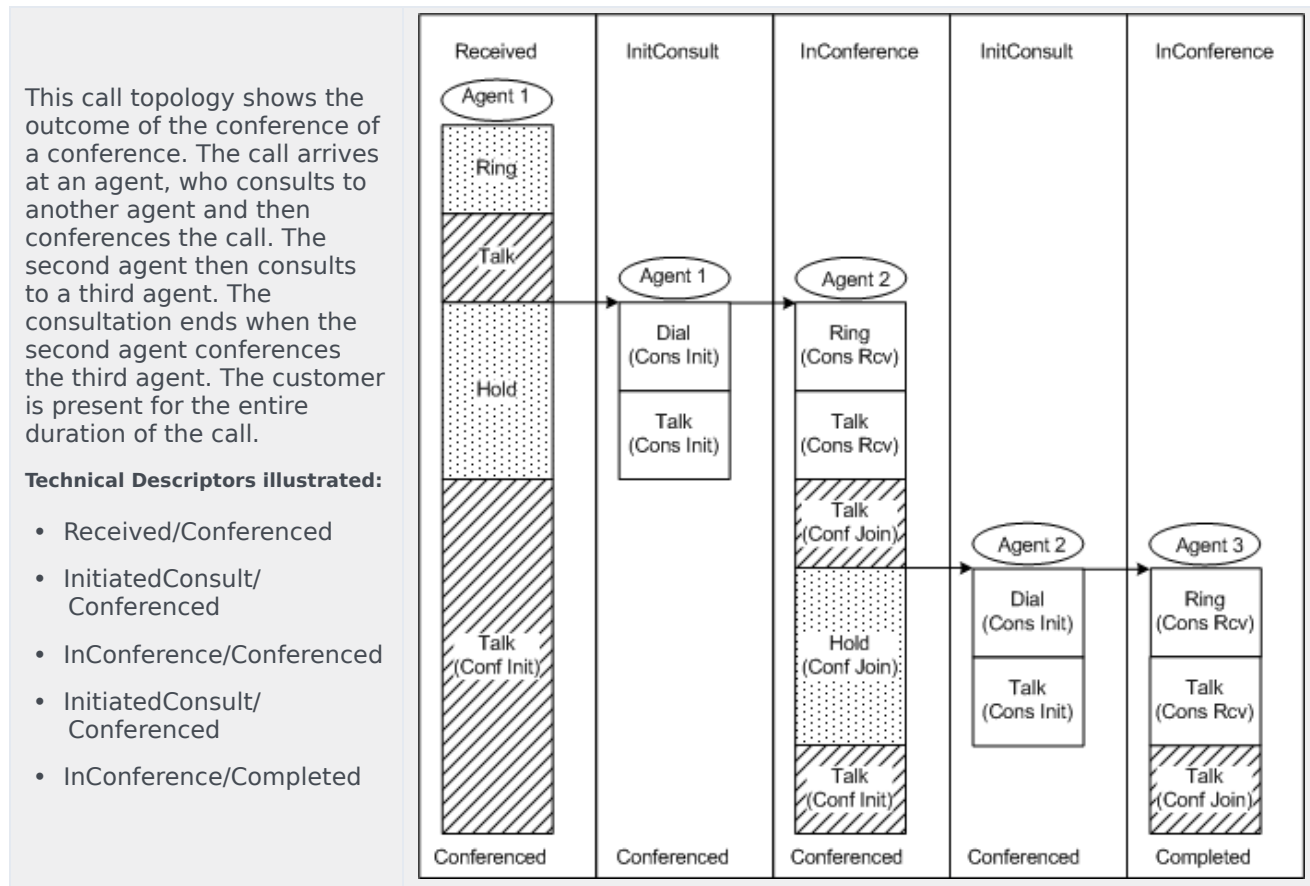

Consult and conference of a conference — Customer leaves

This call topology shows the outcome of the conference of a conference. The call arrives at an agent, who consults to another agent and then conferences the call. The second agent then consults to a third agent. The consultation ends when the second agent conferences the third agent. The customer leaves the call before the second agent consults the third agent.

Technical Descriptors illustrated:

- Received/Conferenced
- InitiatedConsult/Conferenced
- InConference/Conferenced
- InitiatedConsult/Conferenced
- InConference/Completed

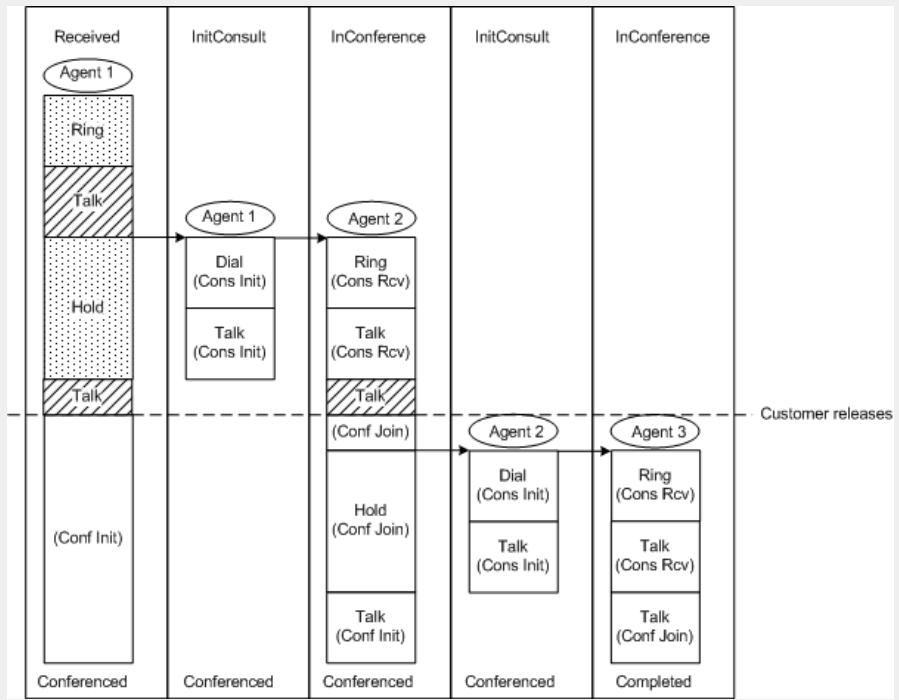

Introduced transfer

This call topology shows the reporting results for a short conference that is treated as an introduced transfer, instead of as a regular conference. An introduced transfer occurs when an agent conferences in another agent and then leaves the call before the threshold specified by the introduced-transfer-threshold configuration option is reached. The transfer is achieved through either a **two-step** or a **single-step** conference.

Two-step introduced transfer

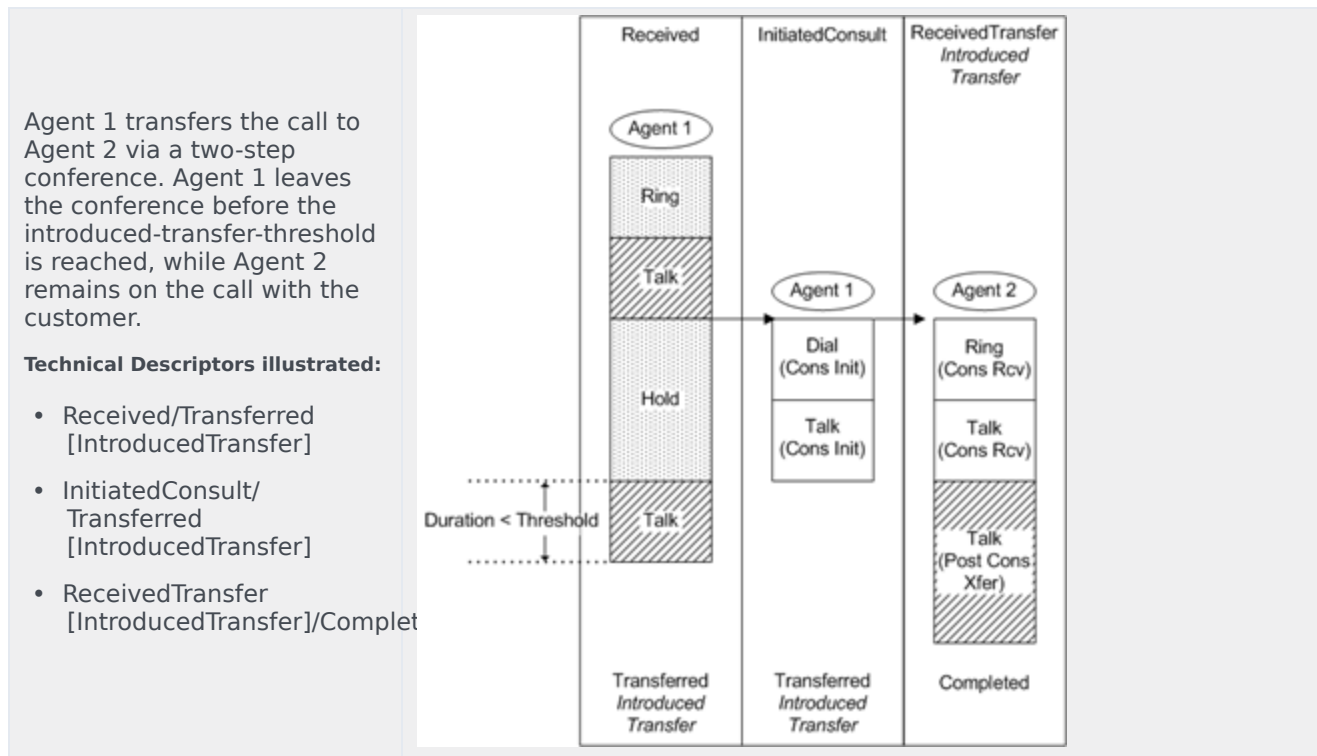

Single-step introduced transfer

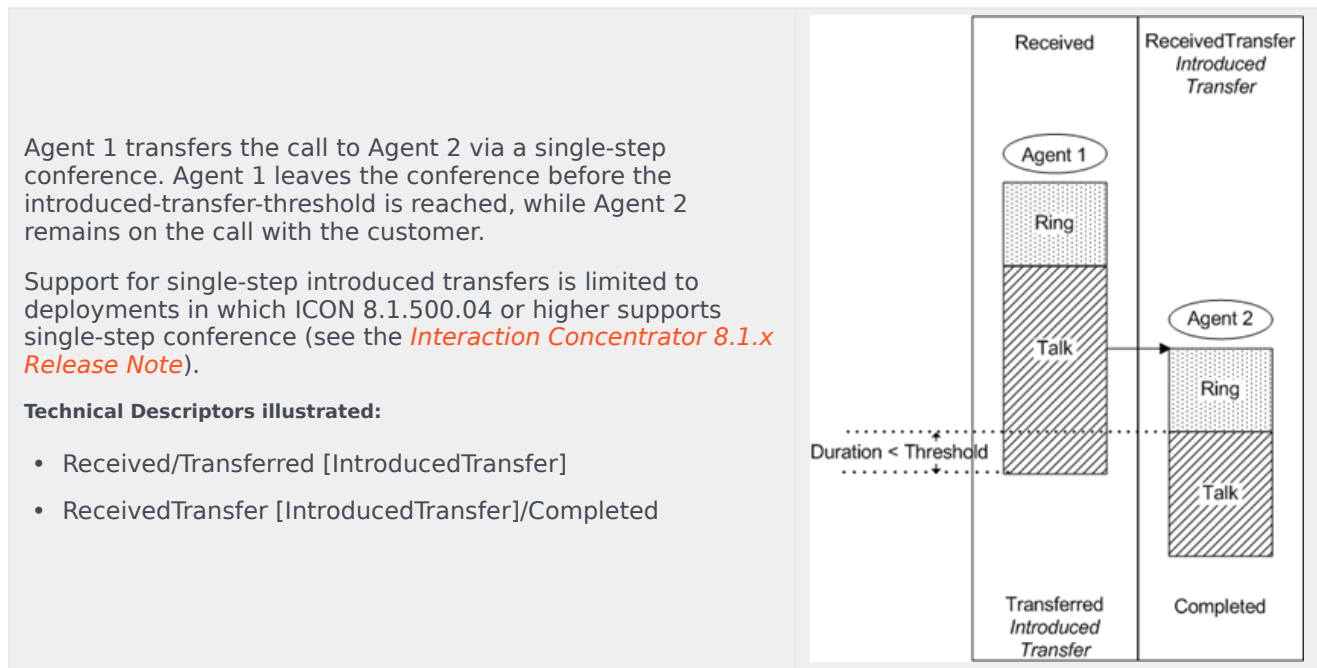

Framework-Only Call Flows: Outbound

This page illustrates outbound voice call flows that Genesys Info Mart supports in deployments with a basic, Framework-only solution. This page does not illustrate Outbound Contact calls.

The following call flows are illustrated:

- [Agent dials outbound call](#)

For other supported call flows, see [Validated Voice Call Flows](#).

Agent dials outbound call

This call topology shows a call flow example of a direct outbound call. An agent dials an off-switch number. After talking with an external party, the agent hangs up.

Technical Descriptors illustrated:

- Initiated/Completed

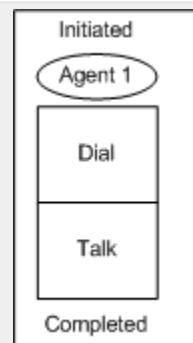

Framework-Only Call Flows: Internal

This page illustrates internal voice call flows that Genesys Info Mart supports in deployments with a basic, Framework-only solution. The following call flows are supported:

- Internal to agent via ACD queue
- Internal to agent directly
- Mute transfer to ACD queue
- Mute transfer to agent
- Consult to agent via ACD queue, and then retrieve
- Consult to agent, and then retrieve
- Consult to agent via ACD queue, and then transfer
- Consult to agent, and then transfer
- Consult to agent via ACD queue, and then conference
- Consult to agent, and then conference

For other supported call flows, see [Validated Voice Call Flows](#).

Internal to agent via ACD queue

This call topology shows the outcome of an internal call to an agent via an ACD queue. An agent initiates a call to the ACD queue, and the interaction is diverted to another agent.

Technical Descriptors illustrated:

- Initiated/Completed
- DivertedTo/Completed

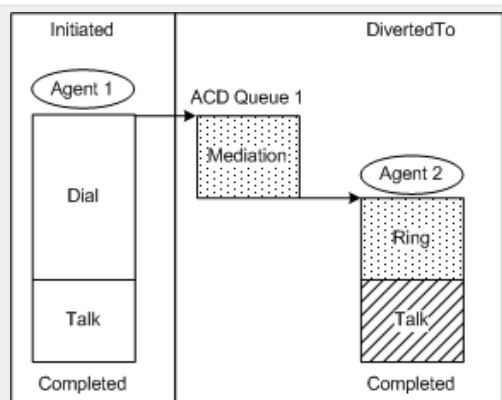

Internal to agent directly

This call topology shows the outcome of a call that an agent initiates directly to another agent.

Technical Descriptors illustrated:

- Initiated/Completed
- Received/Completed

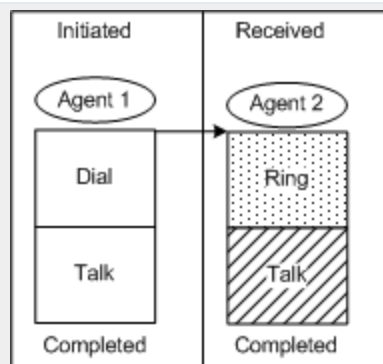

Mute transfer to ACD queue

In this call topology, an agent initiates a call to another agent. One of the agents then mute transfers the call to an ACD queue, and the interaction is diverted to another agent.

There are two possible outcomes of a call that is mute transferred to an ACD queue:

- The receiver (Agent 2) initiates the transfer.
- The initiator (Agent 1) initiates the transfer.

Mute transfer to ACD queue — Call receiver initiates transfer

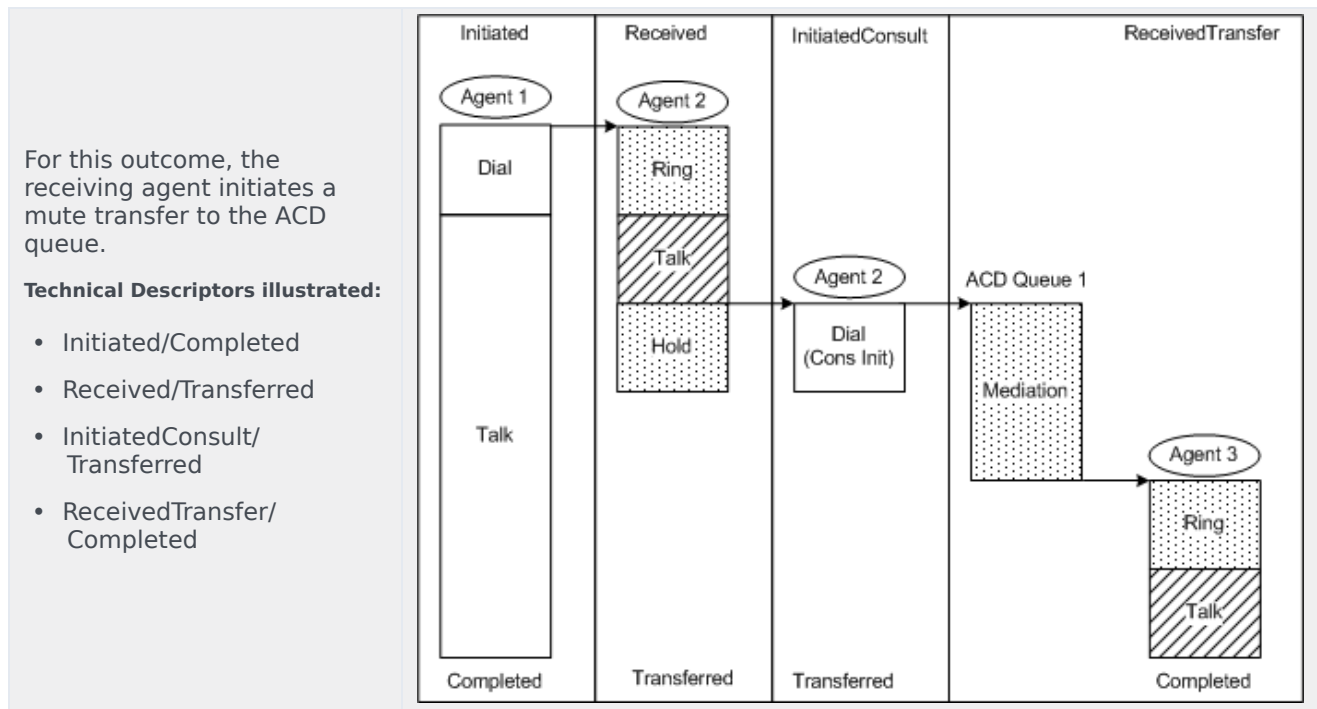

Mute transfer to ACD queue — Call initiator initiates transfer

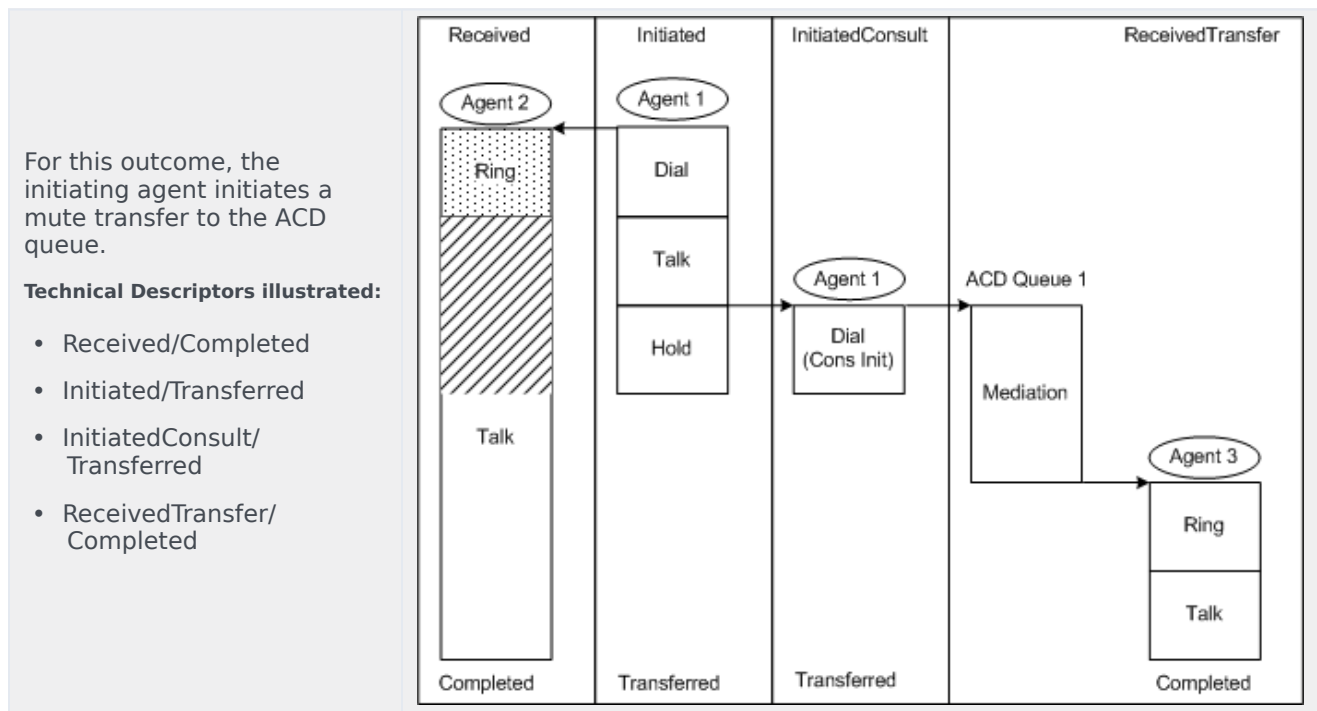

Mute transfer to agent

In this call topology, an agent initiates a call to another agent. One of the agents then mute transfers the call to another agent.

There are two possible outcomes of a call that is mute transferred directly to an agent:

- The receiver (Agent 2) initiates the transfer.
- The initiator (Agent 1) initiates the transfer.

Mute transfer to agent — Call receiver initiates transfer

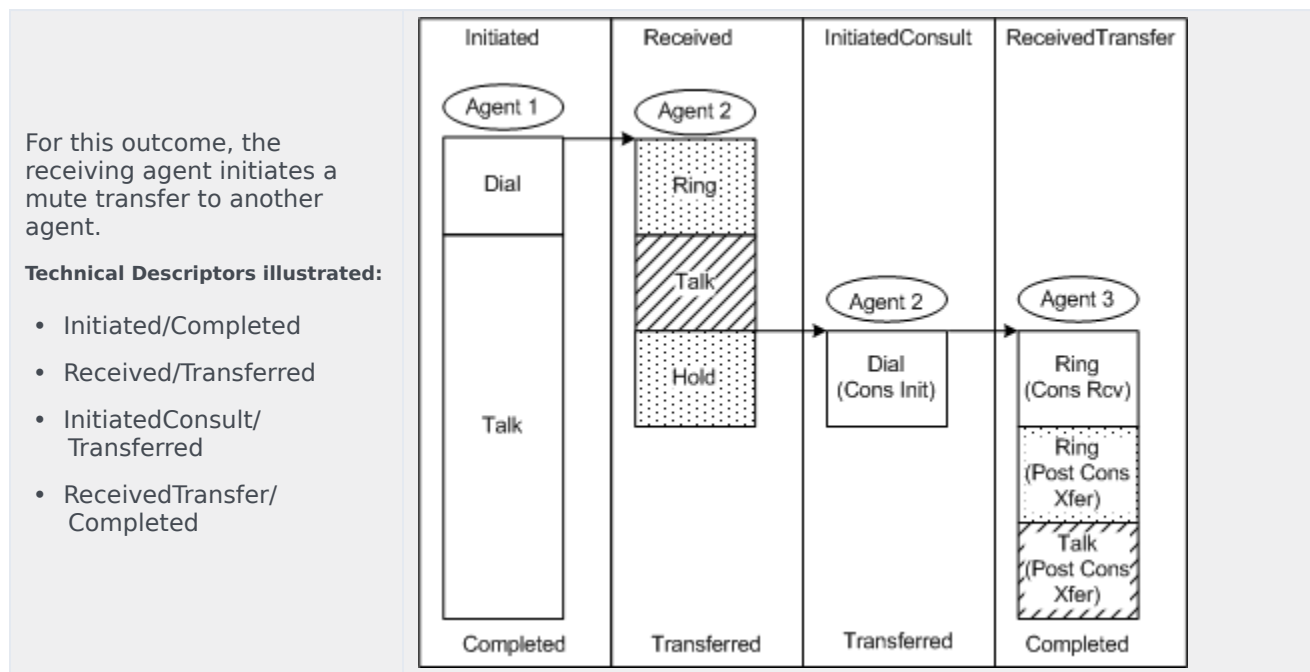

Mute transfer to agent — Call initiator initiates transfer

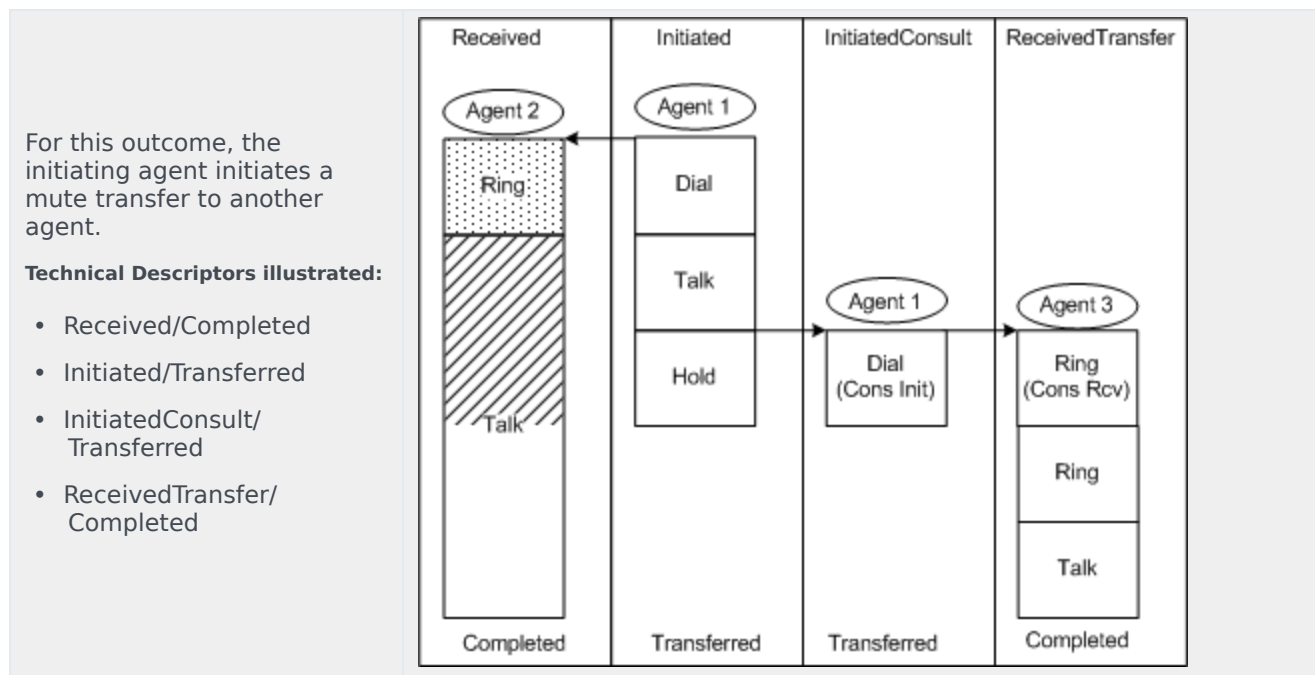

Consult to agent via ACD queue, and then retrieve

In this call topology, an agent initiates a call to another agent. One of the agents then initiates a consultation to an ACD queue, and the interaction is diverted to another agent. The consultation ends when the consulting agent retrieves the interaction.

There are two possible outcomes of a call that is retrieved after a consultation has been initiated:

- The call receiver (Agent 2) initiates the consultation.
- The call initiator (Agent 1) initiates the consultation.

Receiving agent consults to ACD queue, and then retrieves

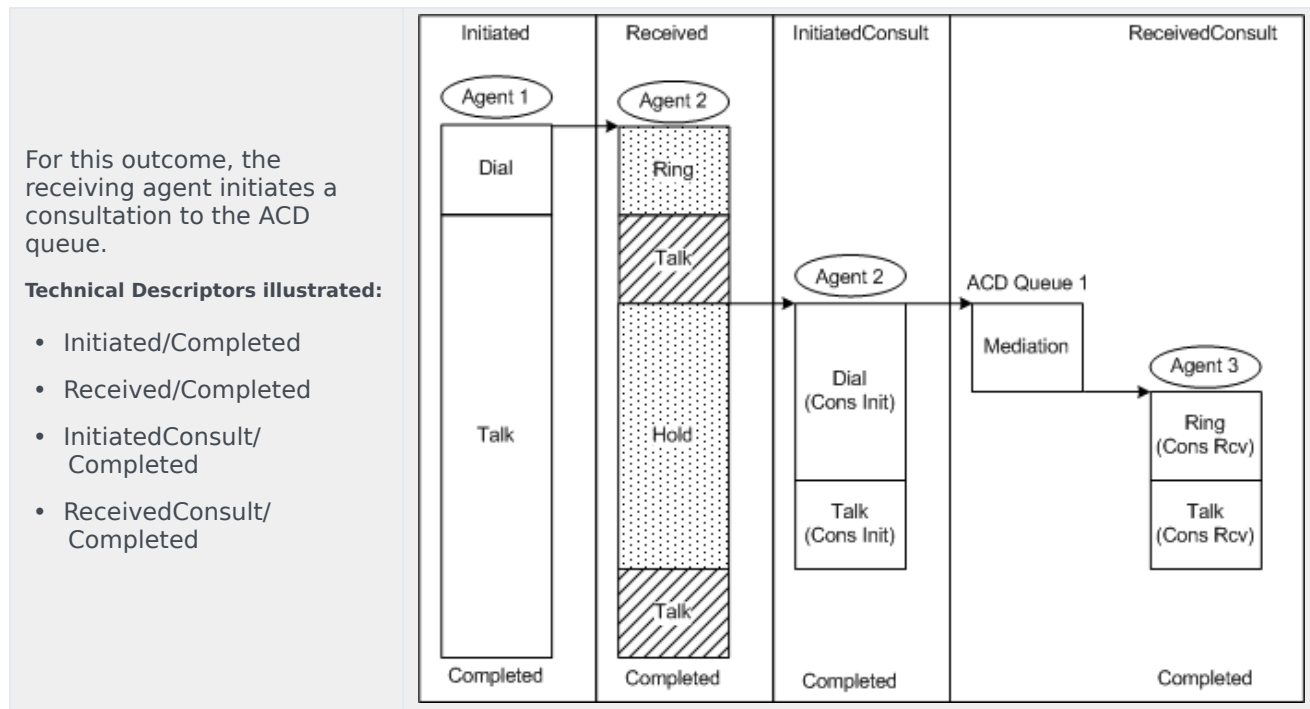

Initiating agent consults to ACD queue, and then retrieves

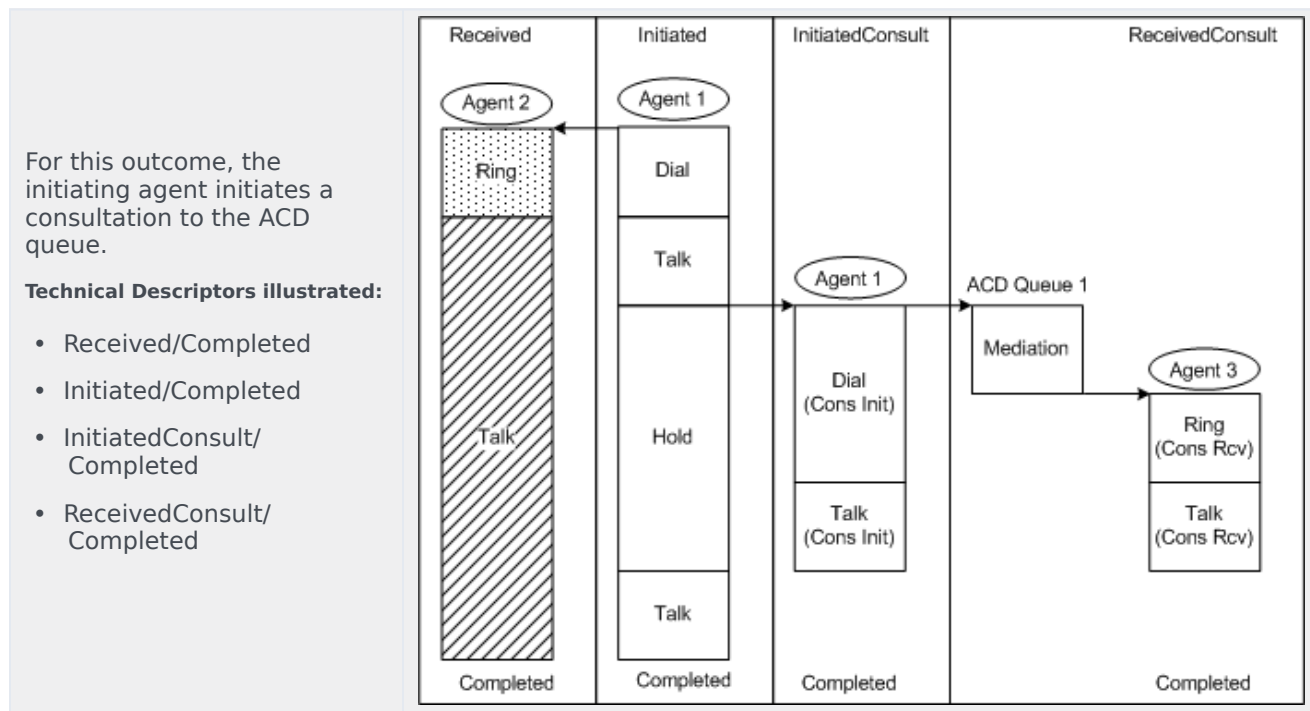

Consult to agent, and then retrieve

In this call topology, an agent initiates a call to another agent. One of the agents then initiates a consultation to a third agent. The consultation ends when the consulting agent retrieves the interaction.

There are two possible outcomes of a call that is retrieved after a consultation has been initiated:

- The call receiver (Agent 2) initiates the consultation.
- The call initiator (Agent 1) initiates the consultation.

Receiving agent consults to another agent, and then retrieves

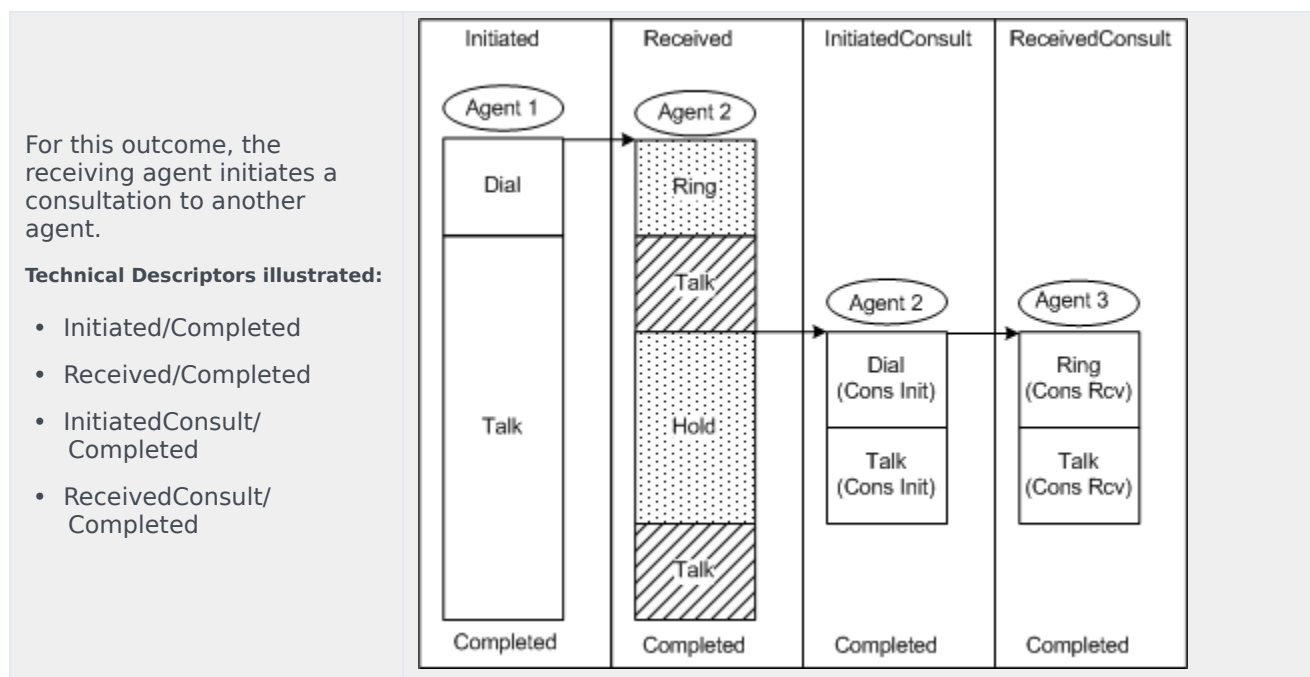

Initiating agent consults to another agent, and then retrieves

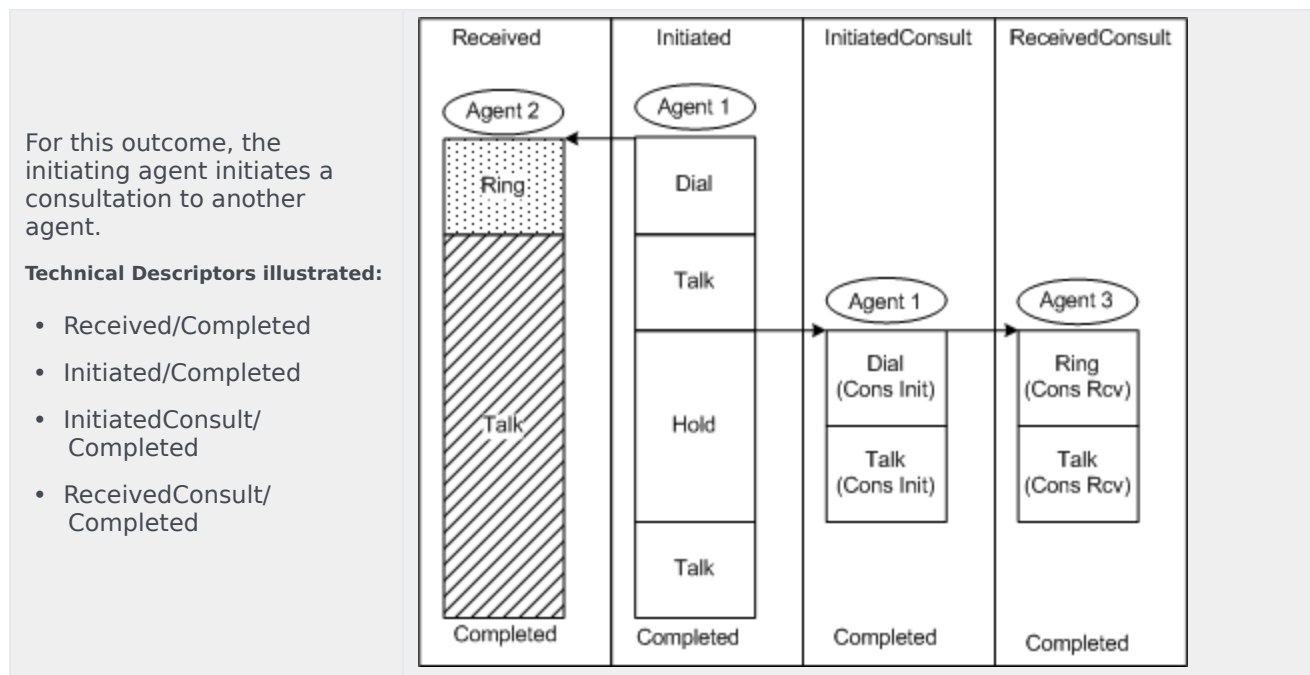

Consult to agent via ACD queue, and then transfer

In this call topology, an agent initiates a call to another agent. One of the agents then initiates a consultation to an ACD queue, and the interaction is diverted to another agent. The consultation ends when the consulting agent transfers the interaction.

There are two possible outcomes of a call that is transferred after a consultation:

- The call receiver (Agent 2) initiates the consultation.
- The call initiator (Agent 1) initiates the consultation.

Receiving agent consults to ACD queue, and then transfers

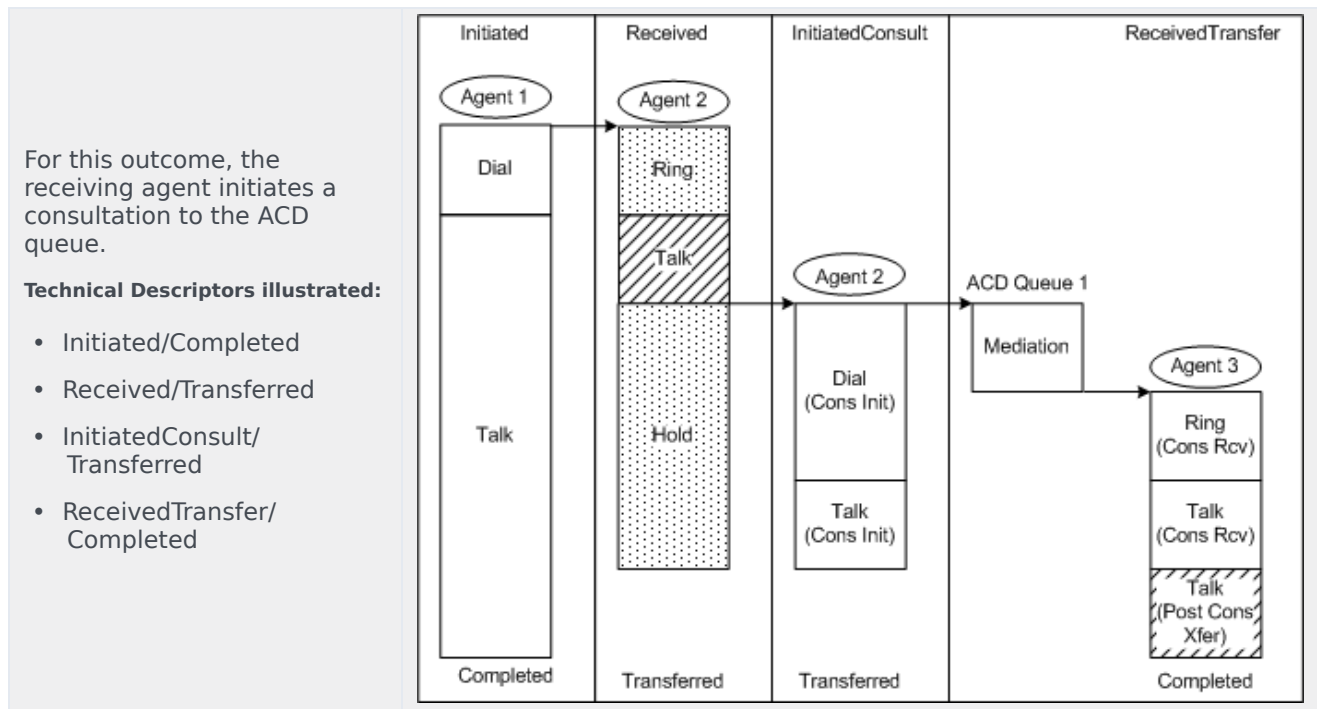

Initiating agent consults to ACD queue, and then transfers

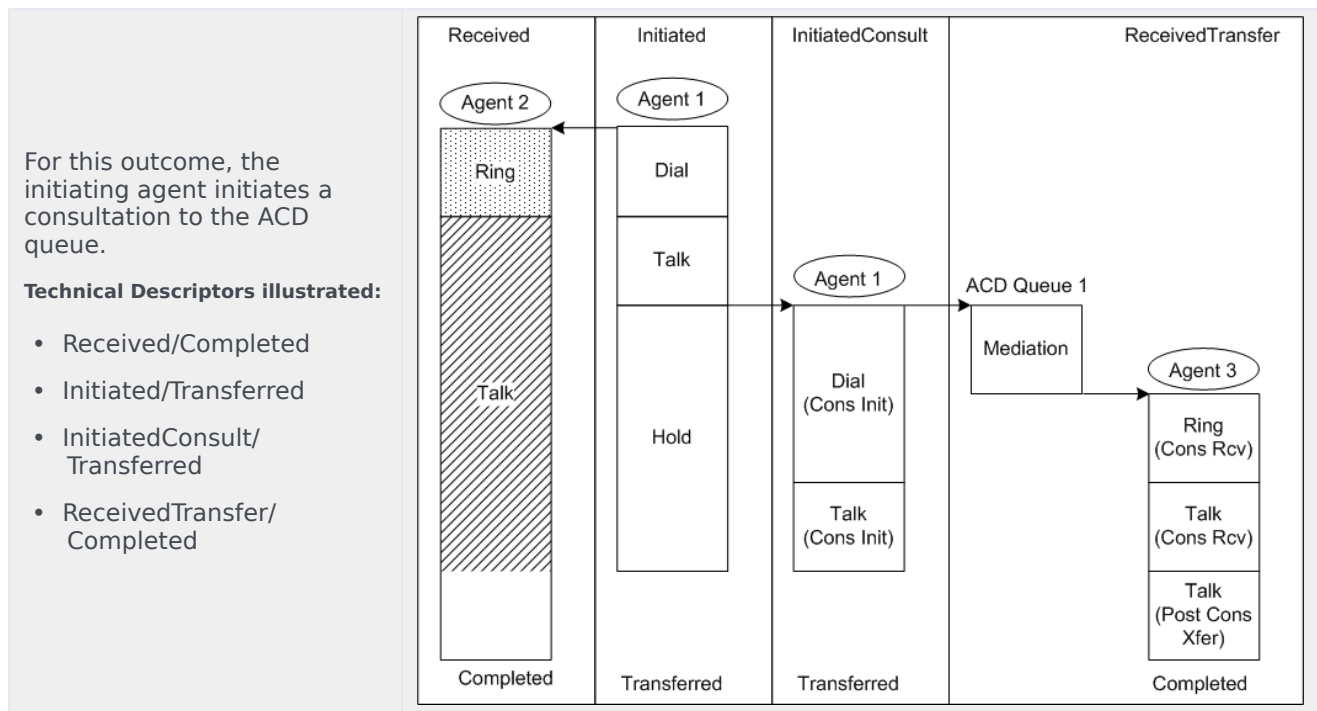

Consult to agent, and then transfer

In this call topology, an agent initiates a call to another agent. One of the agents then initiates a consultation to a third agent. The consultation ends when the consulting agent transfers the interaction.

There are two possible outcomes of a call that is transferred after a consultation has been initiated:

- The call receiver (Agent 2) initiates the consultation.
- The call initiator (Agent 1) initiates the consultation.

Receiving agent consults to another agent, and then transfers

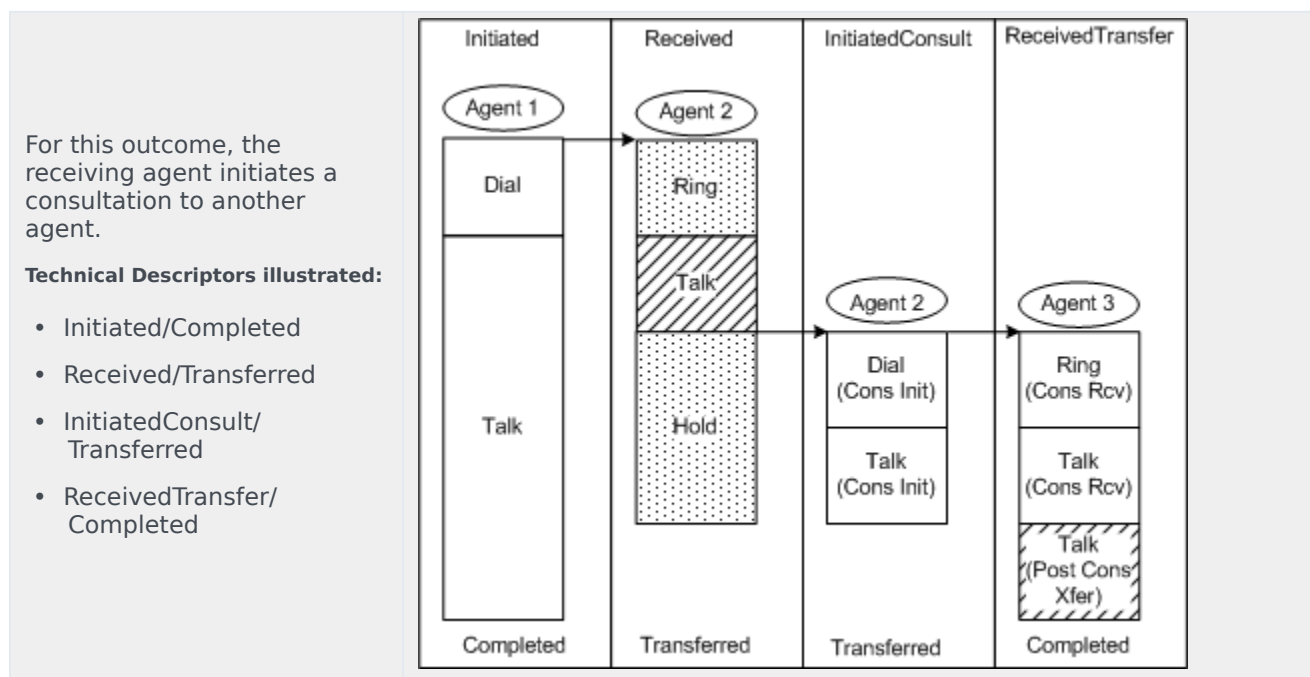

Initiating agent consults to another agent, and then transfers

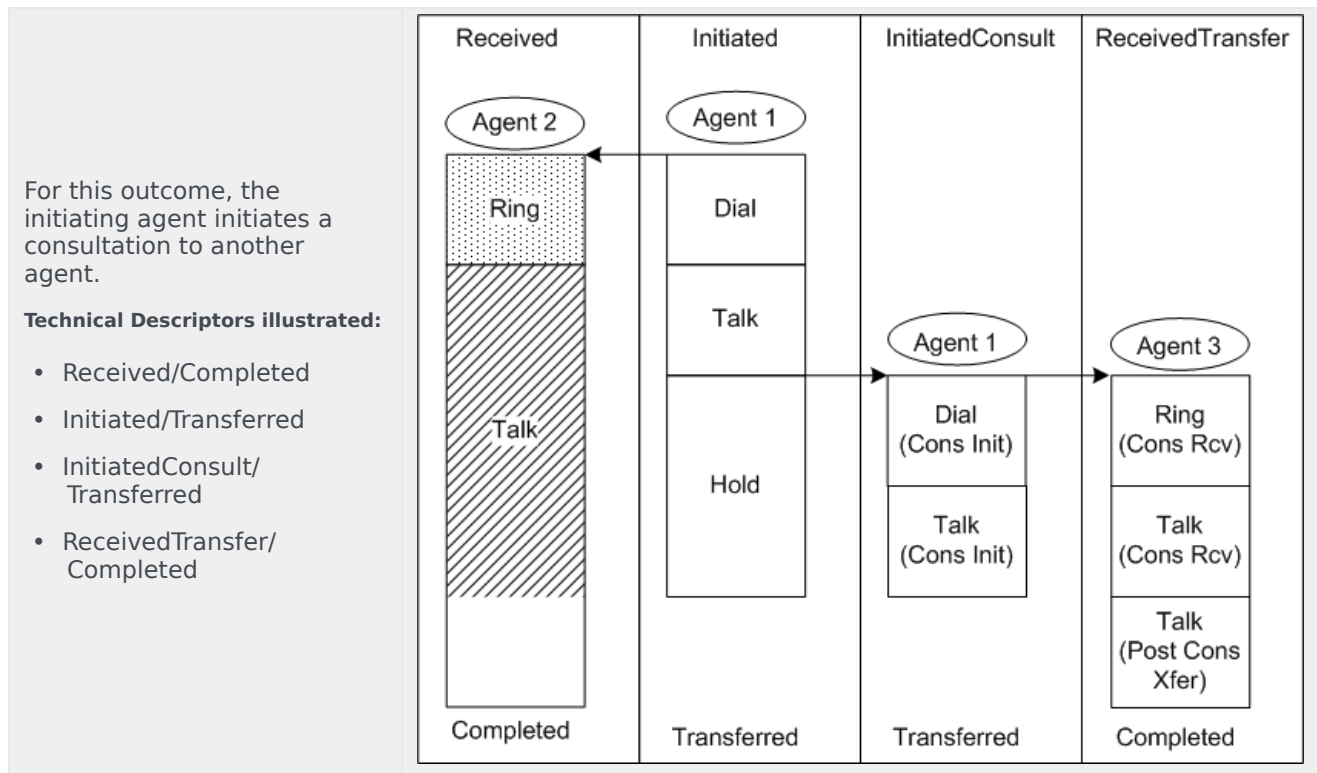

Consult to agent via ACD queue, and then conference

In this call topology, an agent initiates a call to another agent. One agent then initiates a consultation to an ACD queue, and the interaction is diverted to a third agent. The consultation ends when the consulting agent conferences the interaction.

There are two possible outcomes of a call that is conferenced after a consultation:

- The call receiver (Agent 2) initiates the consultation.
- The call initiator (Agent 1) initiates the consultation.

Receiving agent consults to ACD queue, and then conferences

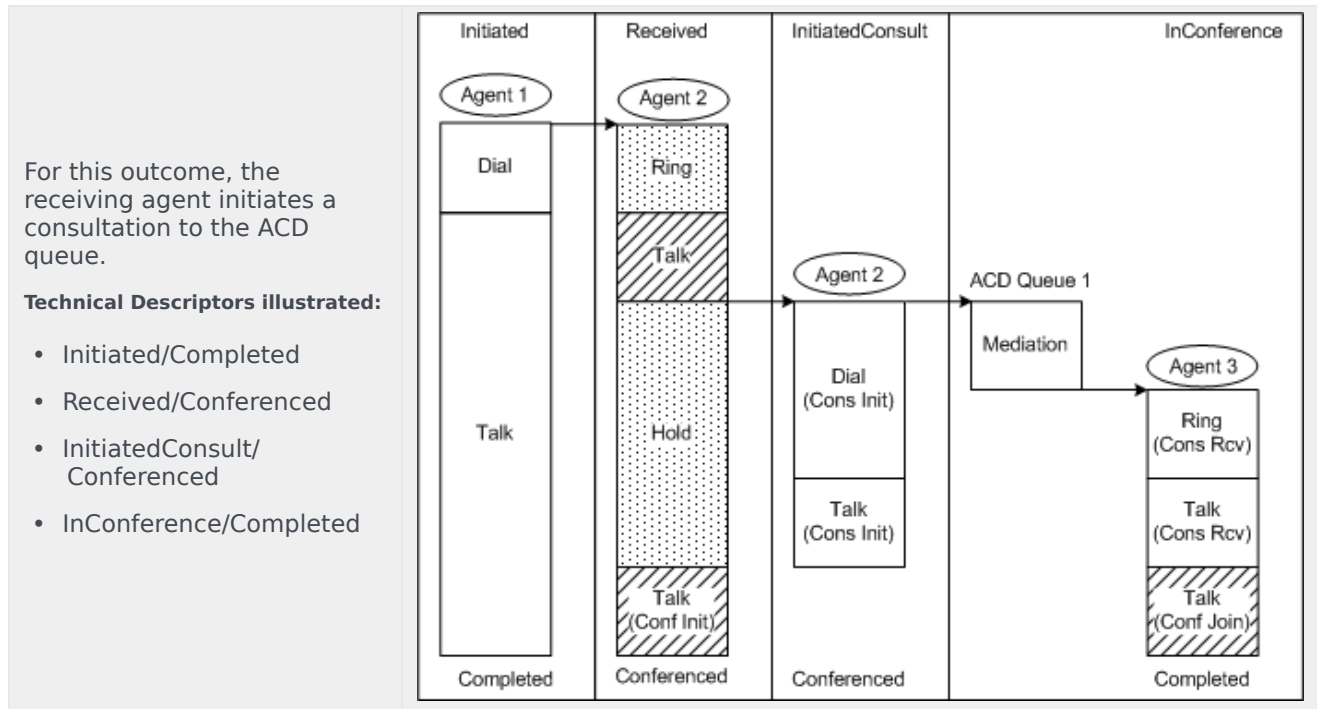

Initiating agent consults to ACD queue, and then conferences

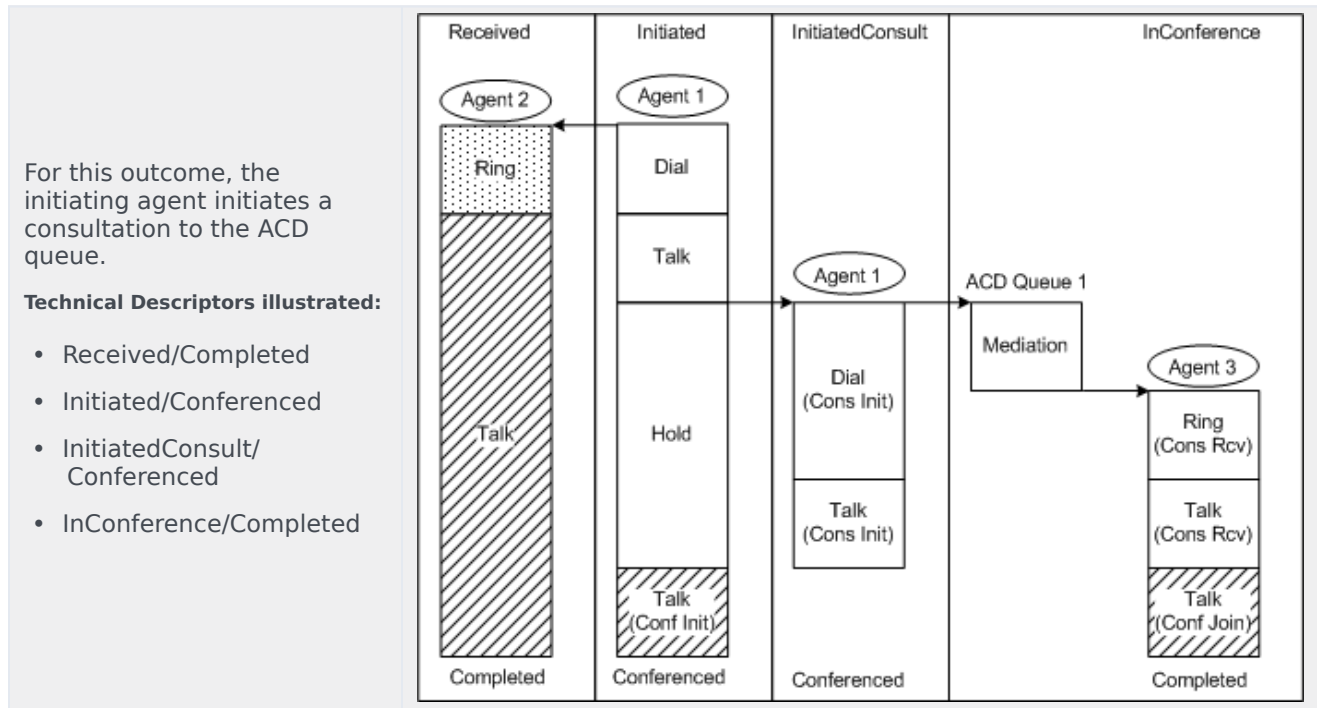

Consult to agent, and then conference

In this call topology, an agent initiates a call to another agent. One agent then initiates a consultation to a third agent. The consultation ends when the consulting agent conferences the interaction.

There are two possible outcomes of a call that is conferenced after a consultation:

- The call receiver (Agent 2) initiates the consultation.
- The call initiator (Agent 1) initiates the consultation.

Receiving agent consults to another agent, and then conferences

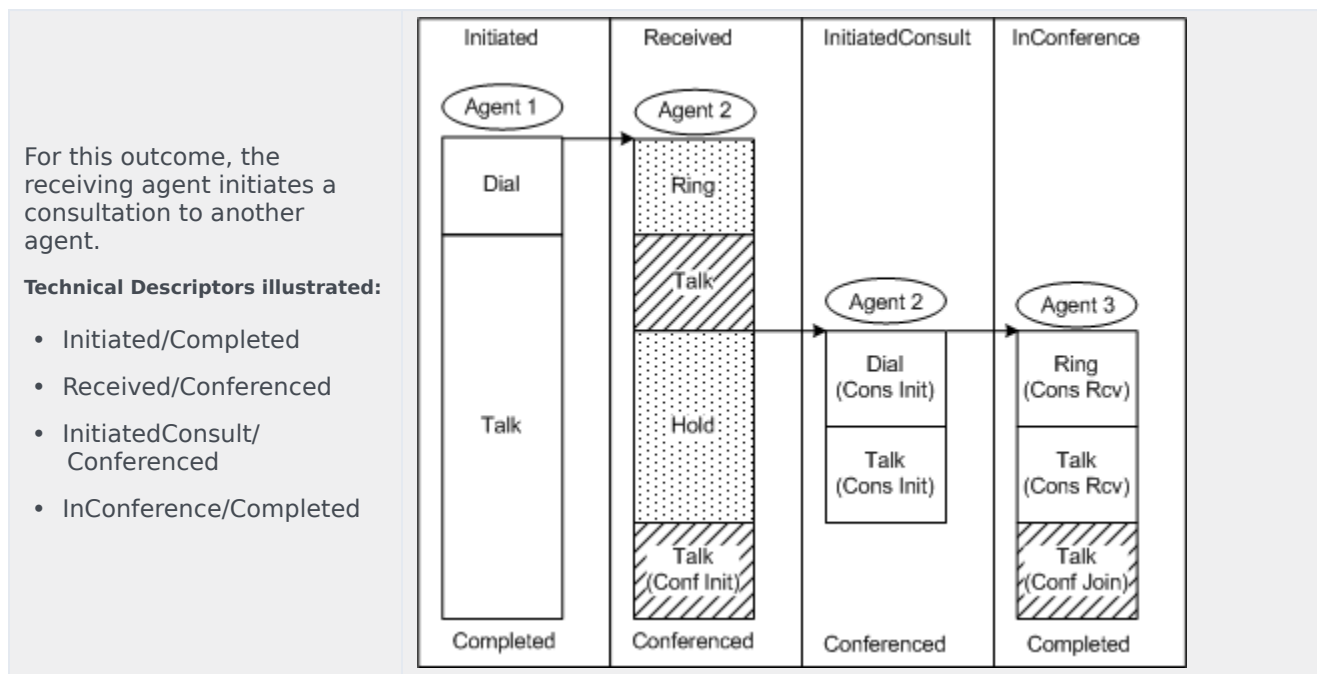

Initiating agent consults to another agent, and then conferences

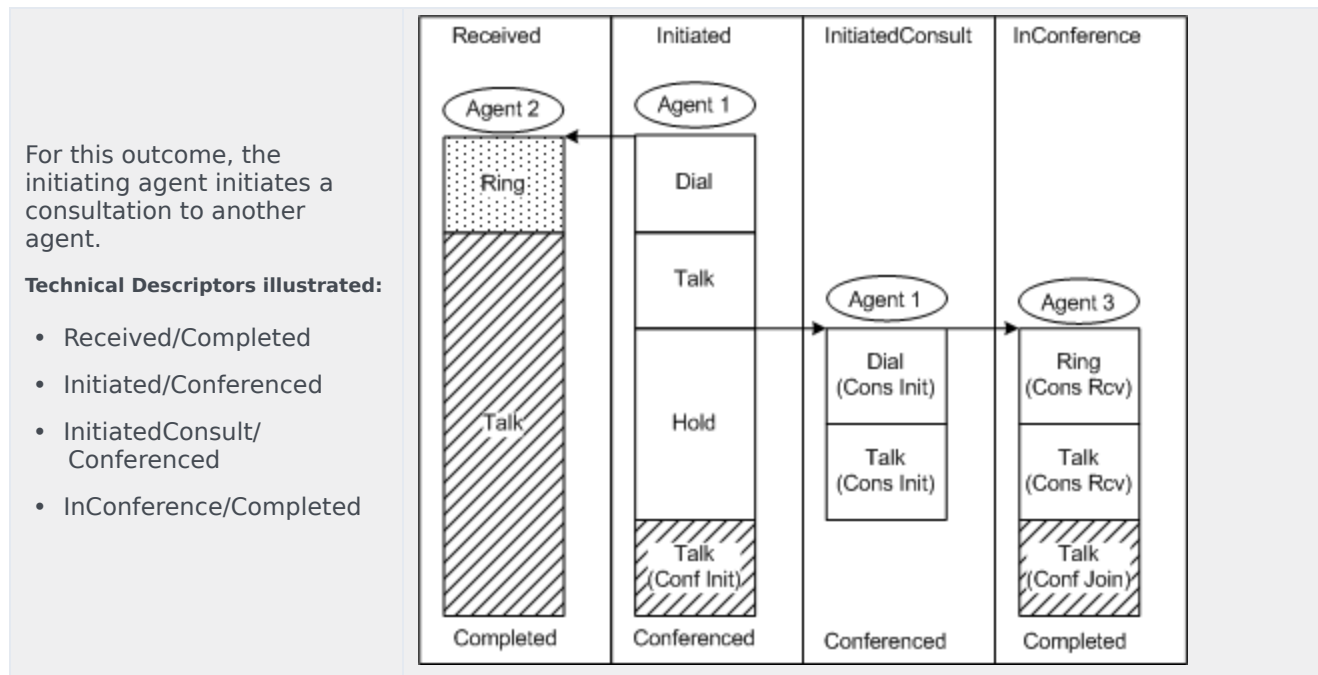

IVR-in-Front-of-Switch Call Flows

This page illustrates inbound voice call flows that are available in IVR solutions where the IVR is deployed in front of the switch.

Voice interactions arrive at an IVR that is visible to the IVR Server's virtual T-Server. Either self-service, or simply front-end identification and segmentation, can be the focus of the IVR application. If the IVR application cannot completely handle the voice interaction, the interaction can be transferred to an ACD queue behind the switch that represents a requested skill, service type, or customer segment. Agents who are logged in to the ACD queues handle the interactions. Alternatively, the interaction can be transferred directly to an agent.

The following IVR-in-front-of-switch call flows are supported:

- [Inbound to IVR DN](#)
- [IVR transfer to ACD queue](#)
- [IVR transfer to agent](#)

For other IVR-in-front-of-switch call flows, see [IVR-in-Front-of-Switch Assisted by Universal Routing Call Flows](#). See also [Validated Voice Call Flows](#).

Inbound to IVR DN

In this call topology, a call arrives at an IVR DN. The following diagrams illustrate two possible outcomes:

- [Call completes normally \(self-service IVR\)](#)
- [Call is abandoned by the customer \(nonself-service IVR\)](#)

Self-service IVR — Call completes normally

This diagram depicts the IRF representation of the call topology when the call completes normally in the case of a self-service (SS) IVR (when the IVR is in its own box).

Technical Descriptors illustrated:

- Received/Completed

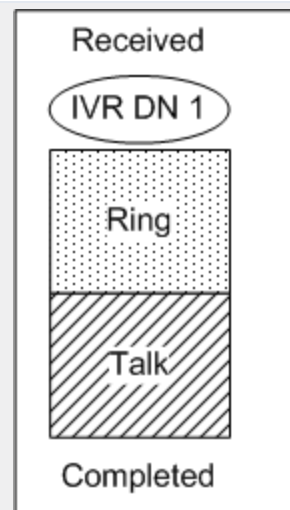

Nonself-service IVR — Call abandoned by customer

This diagram depicts the IRF representation of the call topology when the call is abandoned by the customer. This is the nonself-service (nonSS) IVR case.

Technical Descriptors illustrated:

- Received/CustomerAbandoned [AnsweredByOther]

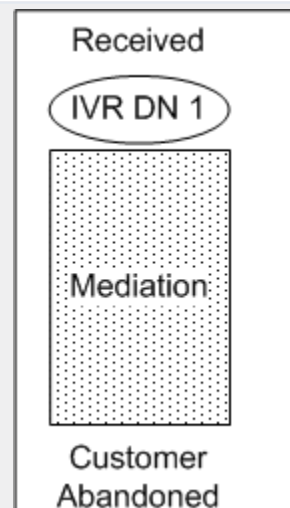

IVR transfer to ACD queue

In this call topology, a call arrives at an IVR DN, which hook-flash transfers the interaction to an ACD queue, from which the call is eventually distributed to an agent. The following diagrams illustrate two possible reporting results:

- **Transfer to ACD queue from an SS IVR**

- Transfer to ACD queue from a nonSS IVR

IVR transfer to ACD queue — Self-service IVR

This diagram depicts the IRF representation of the call topology in the case of an SS IVR (when the IVR is in its own box).

Technical Descriptors illustrated:

- Received/Transferred
- ReceivedTransfer/Completed

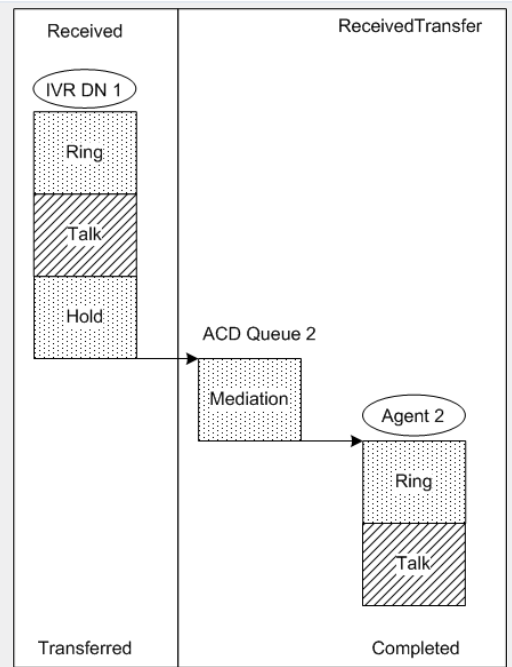

IVR transfer to ACD queue — Nonself-service IVR

This diagram depicts the IRF representation of the call topology in the case of a nonSS IVR.

Technical Descriptors illustrated:

- DivertedTo/Completed

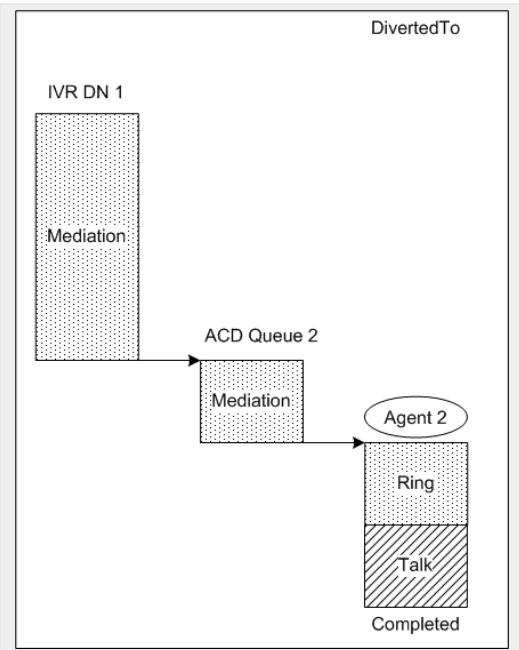

IVR transfer to agent

In this call topology, a call arrives at an IVR DN, which hook-flash transfers the interaction to an agent. The following diagrams illustrate two possible reporting results:

- [Transfer to agent from an SS IVR](#)
- [Transfer to agent from a non-SS IVR](#)

IVR transfer to agent — Self-service IVR

This diagram depicts the IRF representation of the call topology in the case of an SS IVR.

Technical Descriptors illustrated:

- Received/Transferred
- ReceivedTransfer/Completed

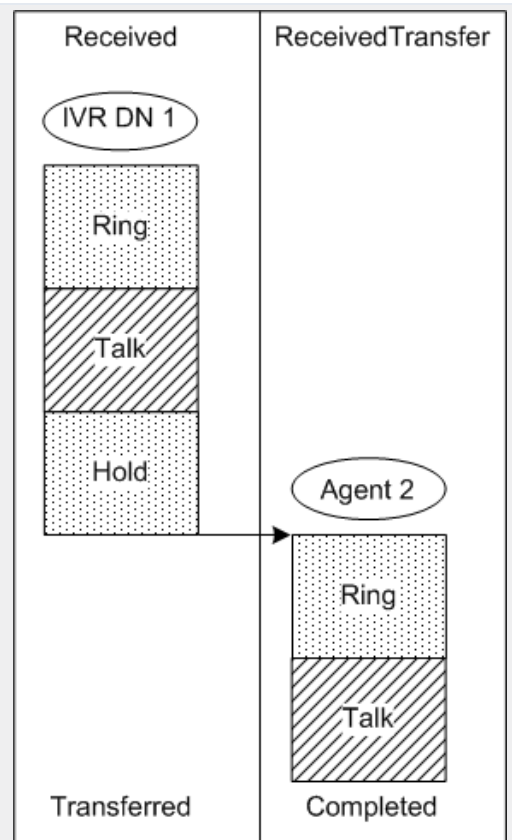

IVR transfer to agent — Nonservice IVR

This diagram depicts the IRF representation of the call topology in the case of a nonSS IVR.

Technical Descriptors illustrated:

- Received/Completed

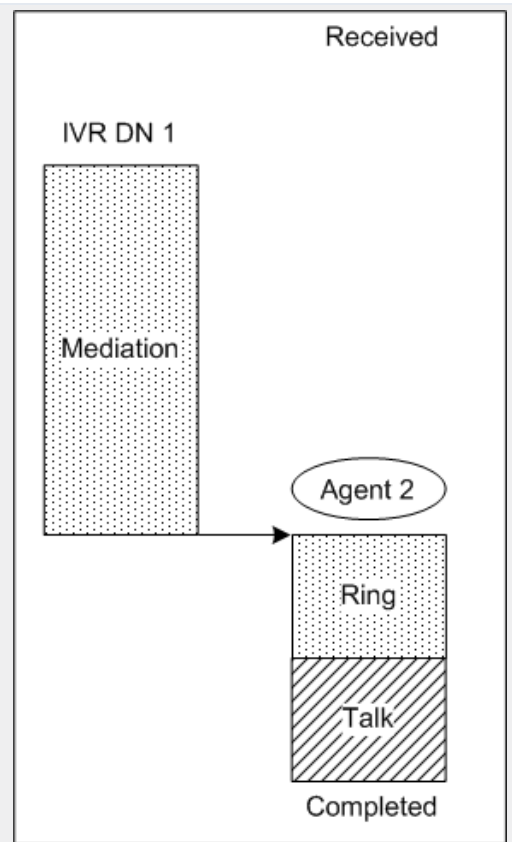

IVR-Behind-Switch Call Flows

This page illustrates inbound voice call flows that are available in IVR solutions where the IVR is deployed behind the switch.

Voice interactions that arrive at the switch are queued to an ACD queue, where the ACD positions are actually IVR DN's. Either self-service, or simply front-end identification and segmentation, can be the focus of the IVR application. If the IVR application cannot completely handle the voice interaction, the interaction can be transferred to an ACD queue that represents a requested skill, service type, or customer segment. Agents who are logged in to the ACD queues handle the interactions.

The following IVR-behind-switch call flows are supported:

- [Inbound to IVR via ACD queue](#)
- [Inbound to IVR directly](#)
- [Mute transfer to ACD queue](#)
- [Mute transfer to agent](#)

Inbound to IVR via ACD queue

In this call topology, the interaction arrives at the ACD queue and is diverted to an IVR DN. The following diagrams illustrate two possible outcomes:

- [Inbound to ACD queue completes normally \(self-service IVR\)](#)
- [Inbound to ACD queue is abandoned by the customer \(nonself-service IVR\)](#)

Inbound to ACD queue (self-service IVR) — Call completes normally

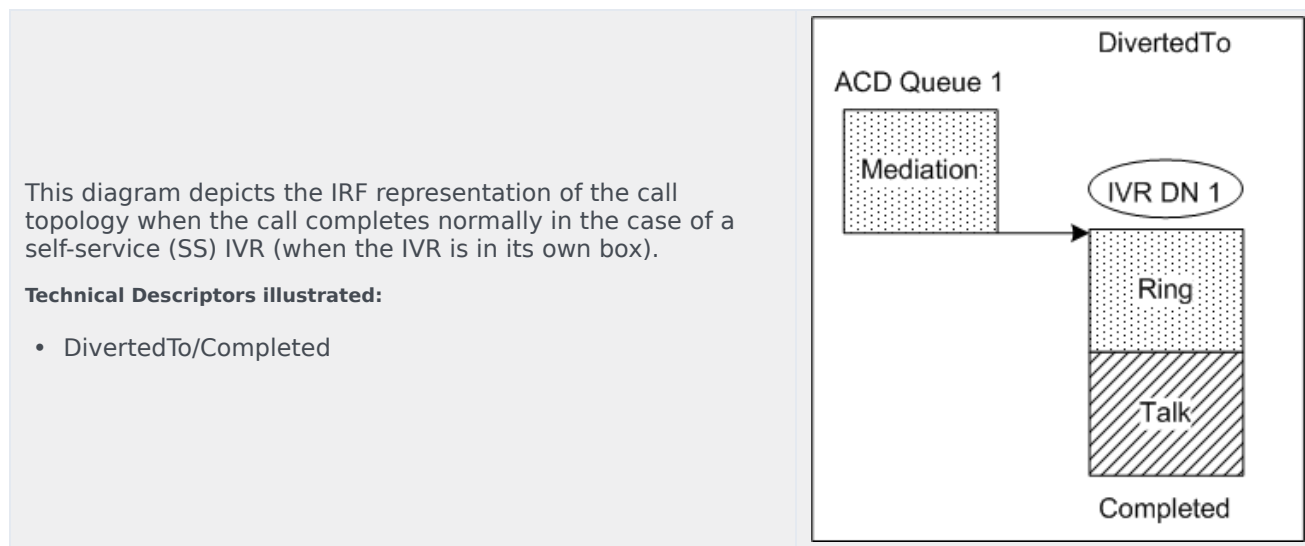

Inbound to ACD queue (nonself-service IVR) — Call abandoned by customer

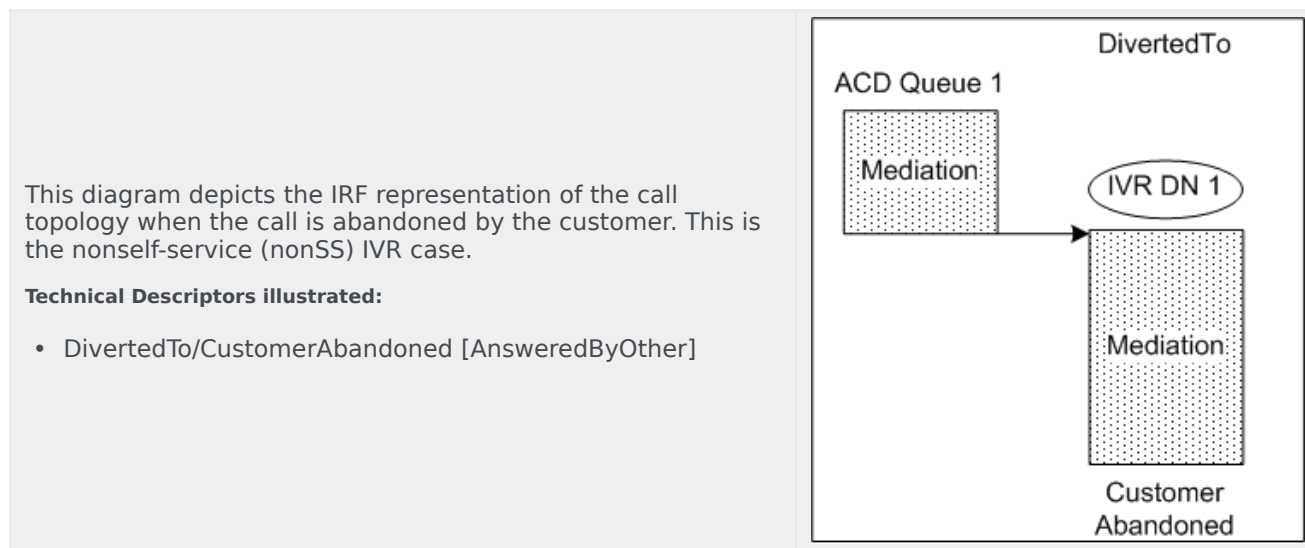

Inbound to IVR directly

In this call topology, the interaction arrives directly at an IVR DN. The following diagrams illustrate two possible outcomes:

- Inbound to IVR completes normally (self-service IVR)
- Inbound to IVR is abandoned by the customer (nonself-service IVR)

Inbound to IVR (self-service IVR) — Call completes normally

This diagram depicts the IRF representation of the call topology when the call completes normally. This is the SS IVR case (when the IVR is in its own box).

Technical Descriptors illustrated:

- Received/Completed

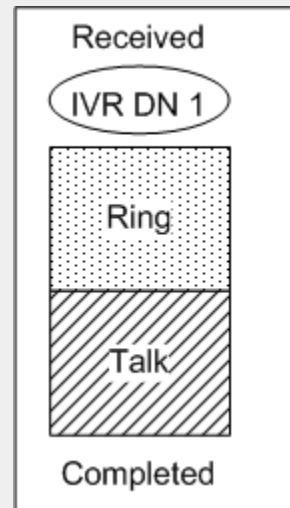

Inbound to IVR (nonself-service IVR) — Call abandoned by customer

This diagram depicts the IRF representation of the call topology when the call is abandoned by the customer. This is the nonSS IVR case.

Technical Descriptors illustrated:

- Received/CustomerAbandoned [AnsweredByOther]

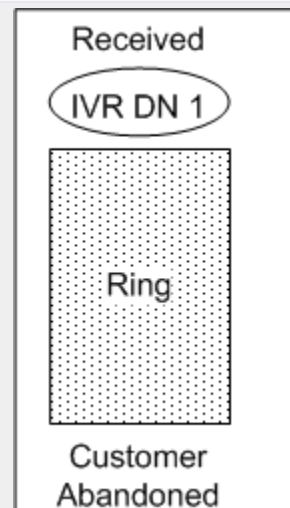

Mute transfer to ACD queue

In this call topology, the interaction is mute transferred to an agent via an ACD queue. The interaction arrives at an ACD queue and is diverted to an IVR DN. The IVR then mute transfers the call to another ACD queue. The following diagrams illustrate two possible cases:

- Mute transfer to ACD queue from a self-service IVR
- Mute transfer to ACD queue from a nonself-service IVR

Mute transfer to ACD queue — Self-service IVR

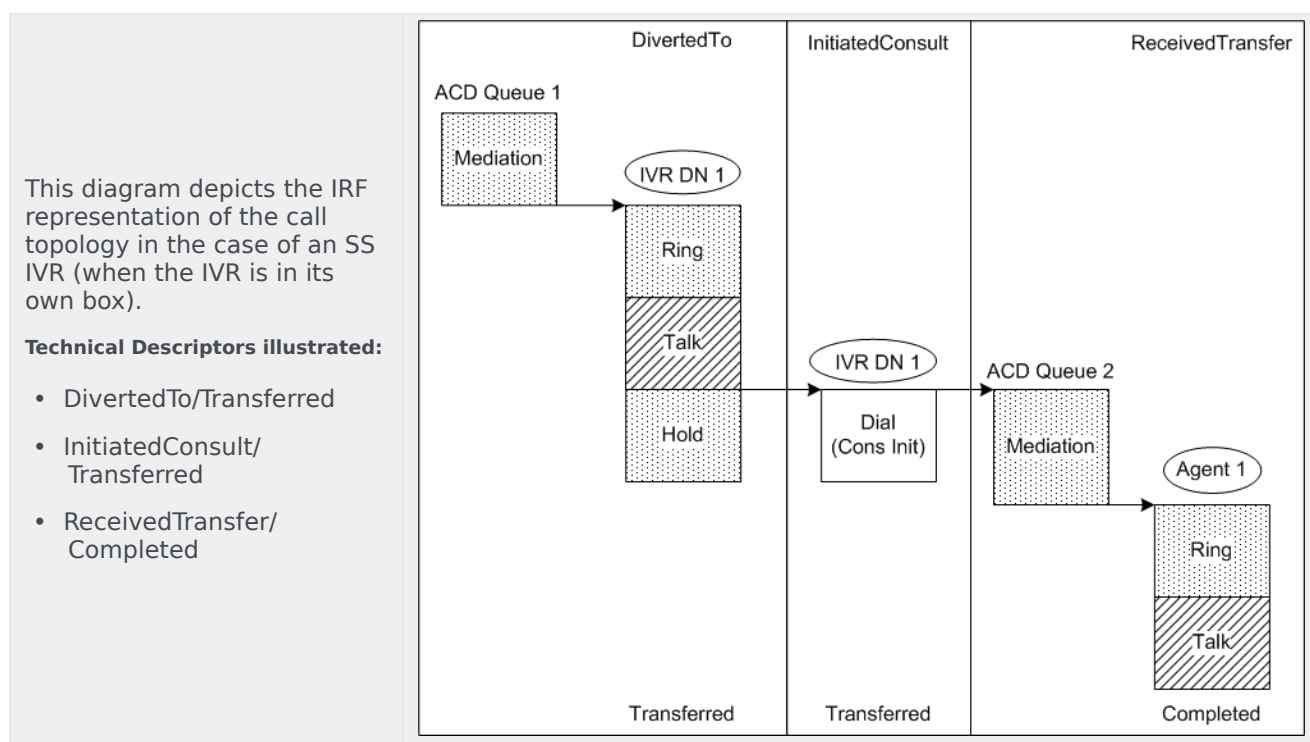

Mute transfer to ACD queue — Nonself-service IVR

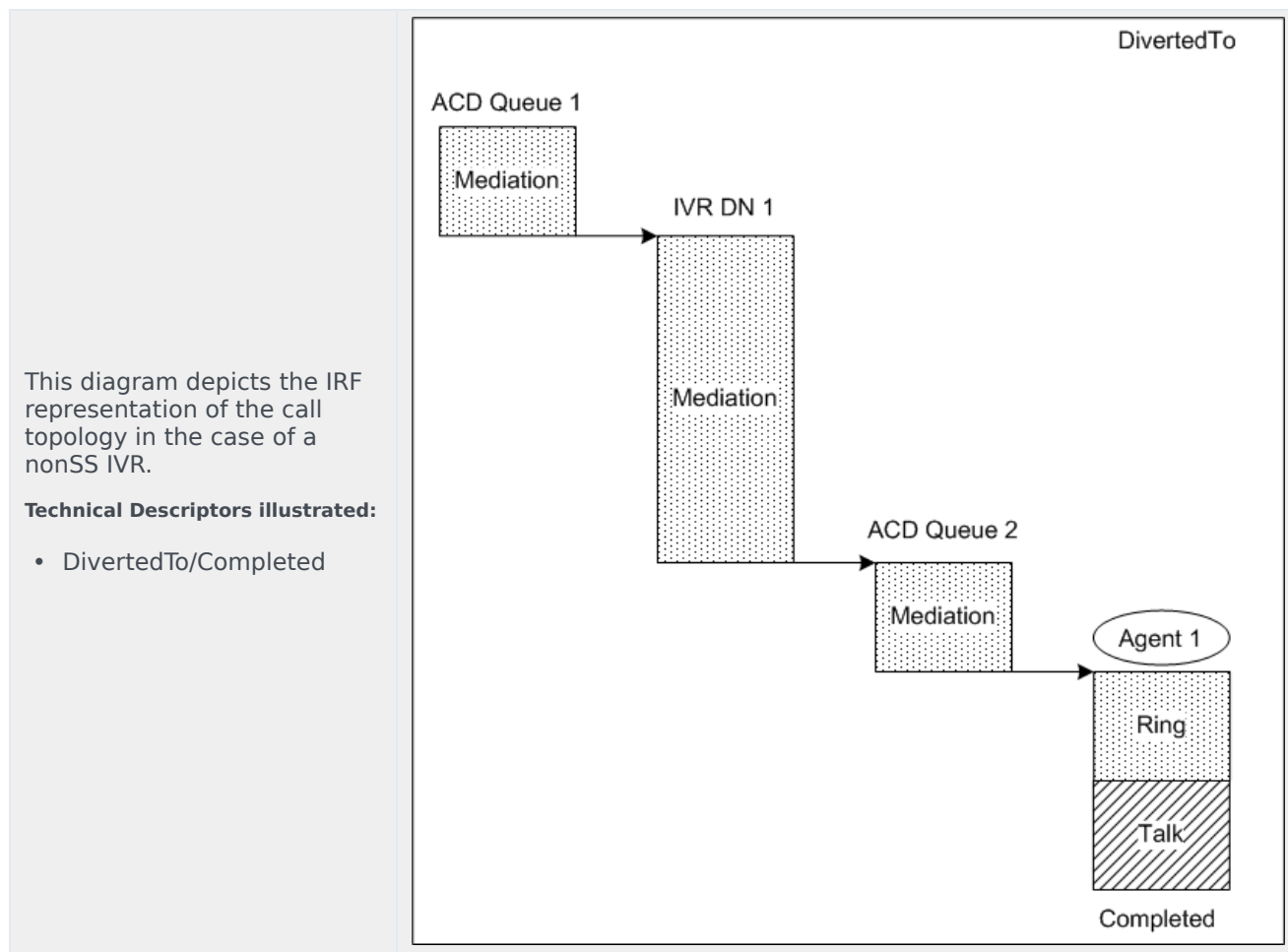

Mute transfer to agent

In this call topology, the interaction is mute transferred to an agent. The interaction arrives at an ACD queue and is diverted to an IVR DN. The IVR then mute transfers the call to an agent. The following diagrams illustrate two possible cases:

- Mute transfer to agent from a self-service IVR
- Mute transfer to agent from a nonself-service IVR

Mute transfer to agent — Self-service IVR

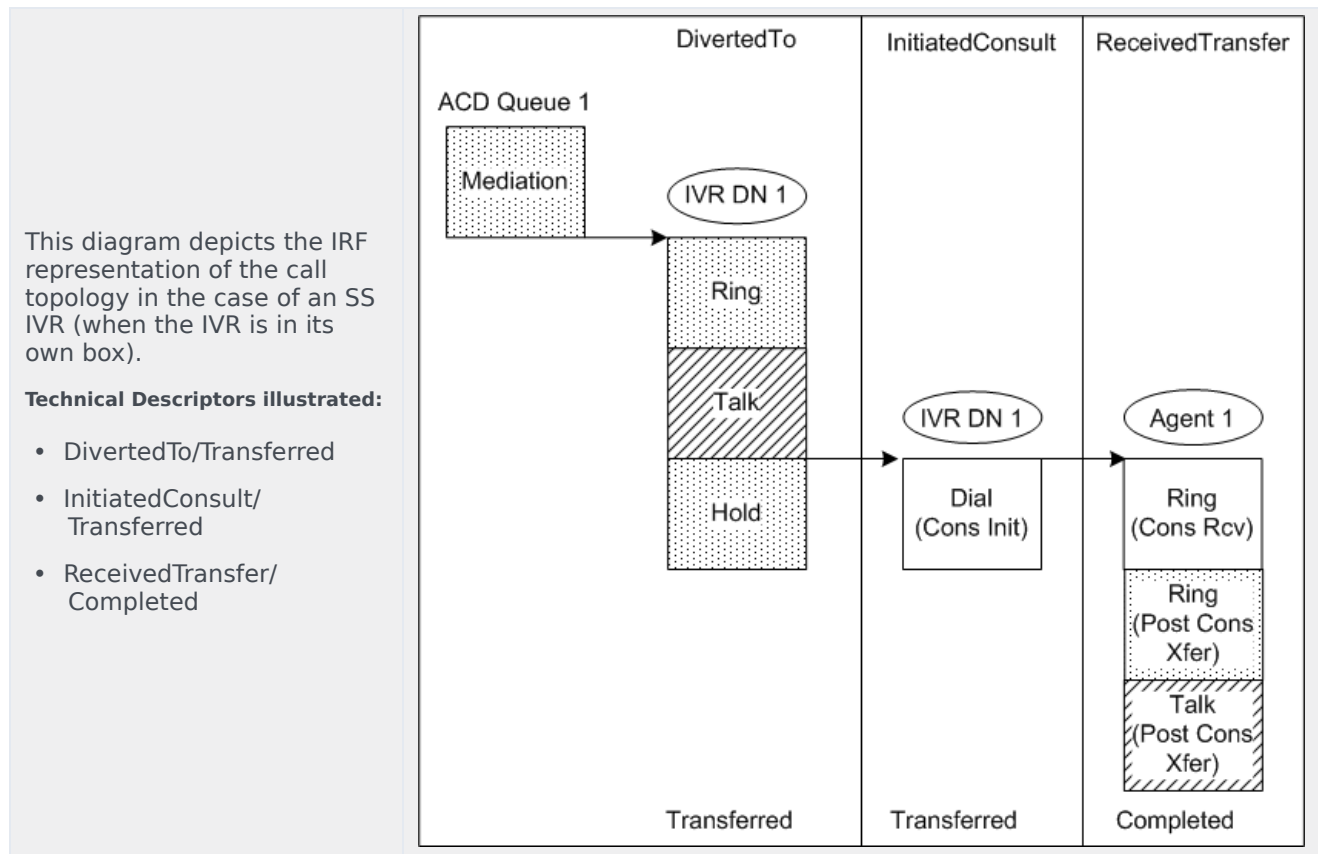

Mute transfer to agent — Nonself-service IVR

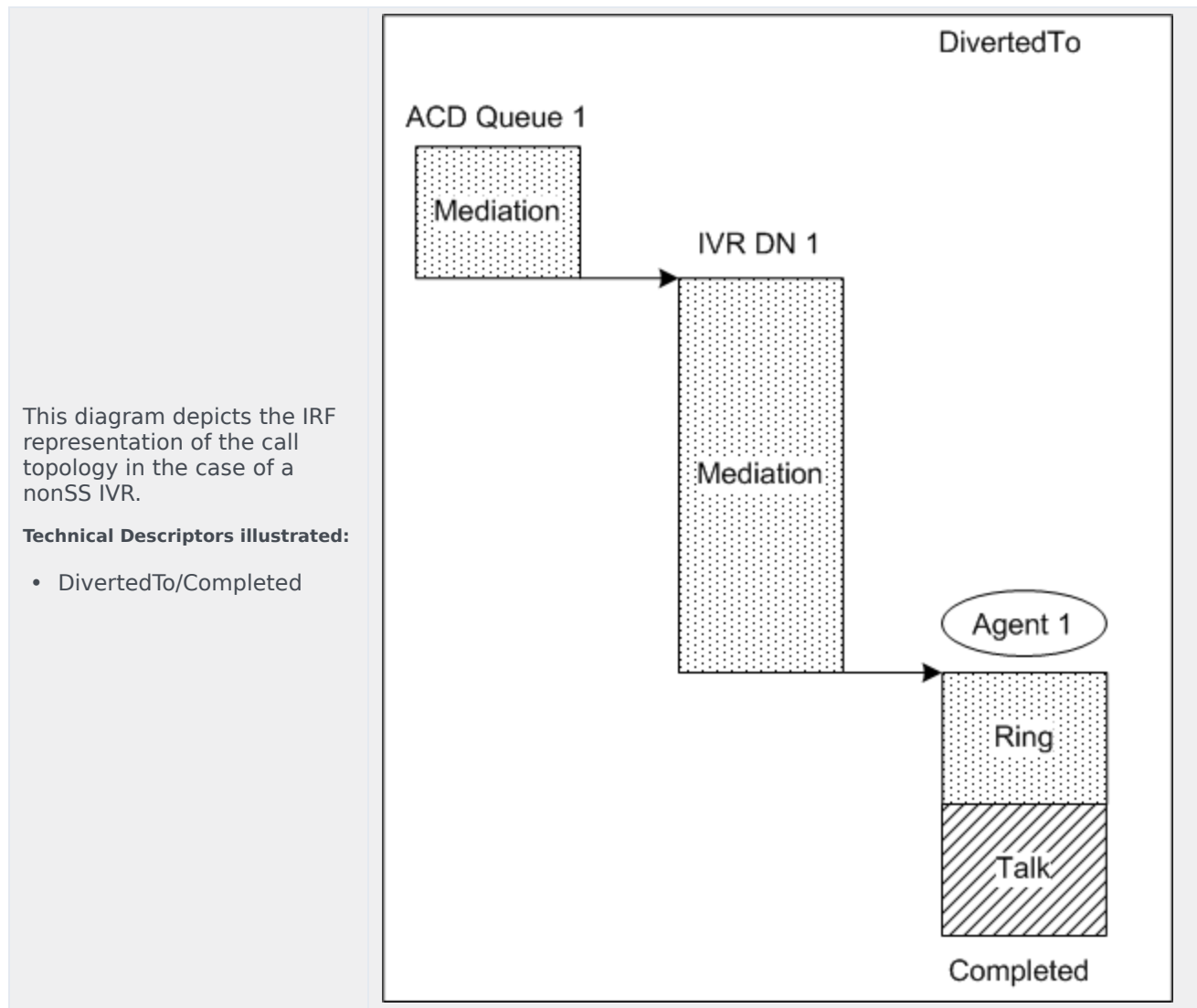

Universal Routing Call Flows

This page illustrates voice inbound call flows that use Genesys Universal Routing.

Voice interactions that arrive at the switch are delivered to a Routing Point. Universal Routing Server (URS) uses ANI, DNIS, or the date and time of day to collect information and select an appropriate routing target. Basic targets are ACD queues and individual DNS. More advanced targets are agent groups, place groups, and skill expressions.

The following call flows are supported:

- **Inbound interaction — Routing Point routes to ACD queue**
- **Inbound interaction — Routing Point routes to agent**

Inbound interaction — Routing Point routes to ACD queue

This call topology shows the outcome of a call that is routed to an agent via an ACD queue. The call arrives at the Routing Point. The Routing Point then routes the call to an ACD queue, and the interaction is diverted to an agent.

This applies to both network routing and enterprise routing. For network routing, Routing Point 1 could be a service number on a network T-Server that routes the voice interaction to ACD Queue 1 on a premise T-Server.

Technical Descriptors illustrated:

- DivertedTo/Completed

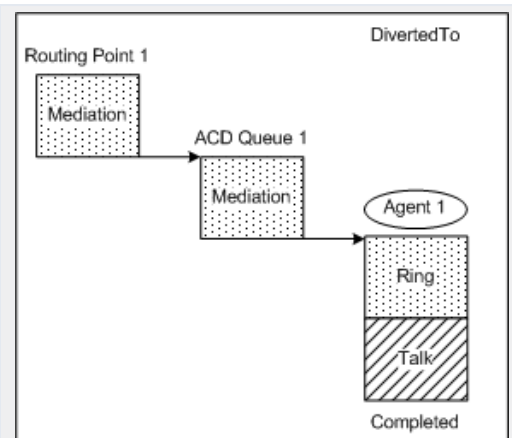

Inbound interaction — Routing Point routes to agent

This call topology shows the outcome of a call that is routed directly to an agent. The call arrives at the Routing Point. The Routing Point then routes the call to an agent.

This applies to both network routing and enterprise routing. For network routing, Routing Point 1 could be a service number on a network T-Server that routes the voice interaction to Agent 1 on a premise T-Server.

Technical Descriptors illustrated:

- RoutedTo/Completed

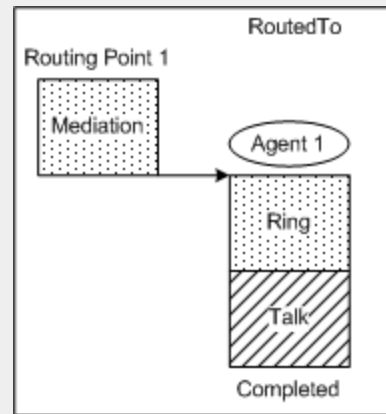

Universal Routing Assisted by IVR-Behind-Switch Call Flows

This page illustrates voice inbound call flows that use IVRs in a Genesys Universal Routing solution, where the IVR is deployed behind the switch.

Voice interactions that arrive at the switch are queued to an ACD queue, where the ACD positions are actually IVR DNs. The IVR collects digits and information about the caller and transfers the call to a Routing Point. Universal Routing uses the collected information to select an appropriate routing target. Basic targets are ACD queues and individual DNs. More advanced targets are agent groups, place groups, and skill expressions.

The following call flows are supported:

- [Inbound call — Routing Point routes to ACD queue](#)
- [Inbound call — Routing Point routes to agent](#)
- [Inbound call to ACD and parallel IVR](#)

Inbound call — Routing Point routes to ACD queue

This call topology shows the outcome of a call that is routed to an agent via an ACD queue. The call arrives at an ACD queue and is diverted to an IVR DN. The IVR then transfers the call to a Routing Point, which routes the call to an ACD queue. The following diagrams illustrate the outcomes for:

- [Self-service IVR](#)
- [Nonself-service IVR](#)

Routing Point routes to ACD queue (self-service IVR)

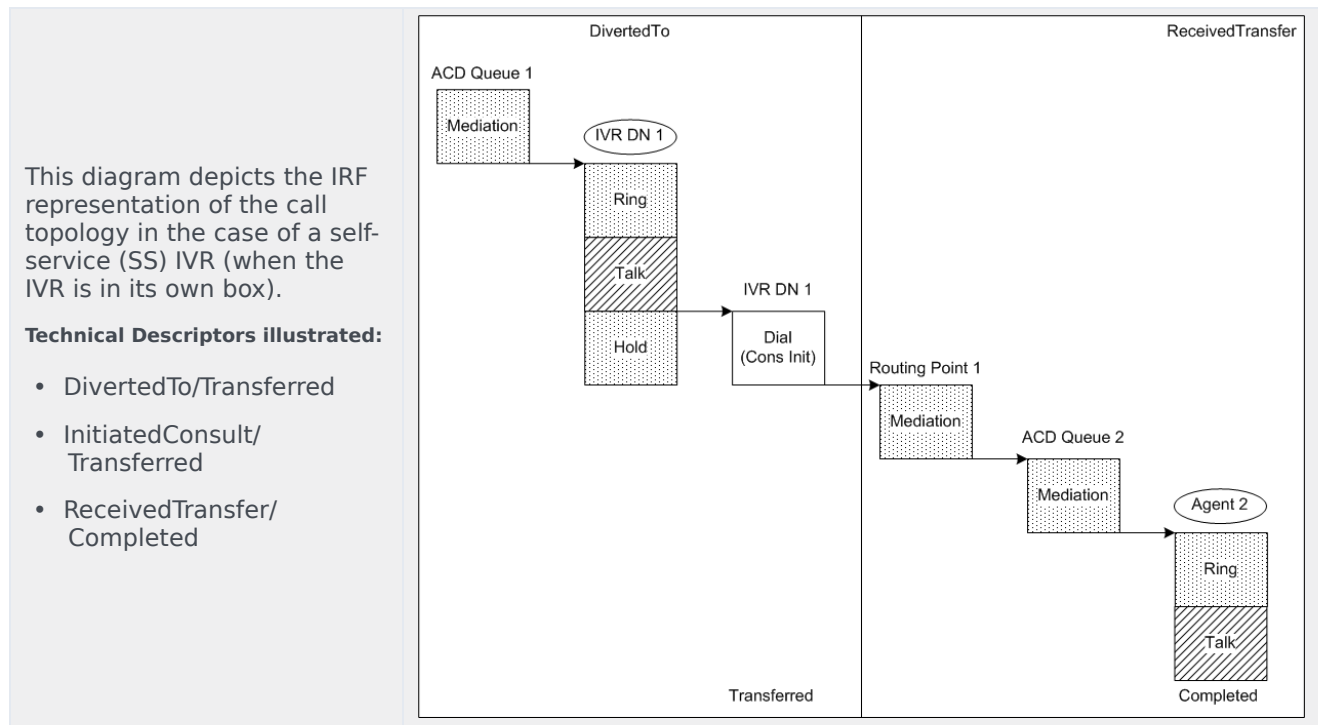

Routing Point routes to ACD queue — (nonself-service IVR)

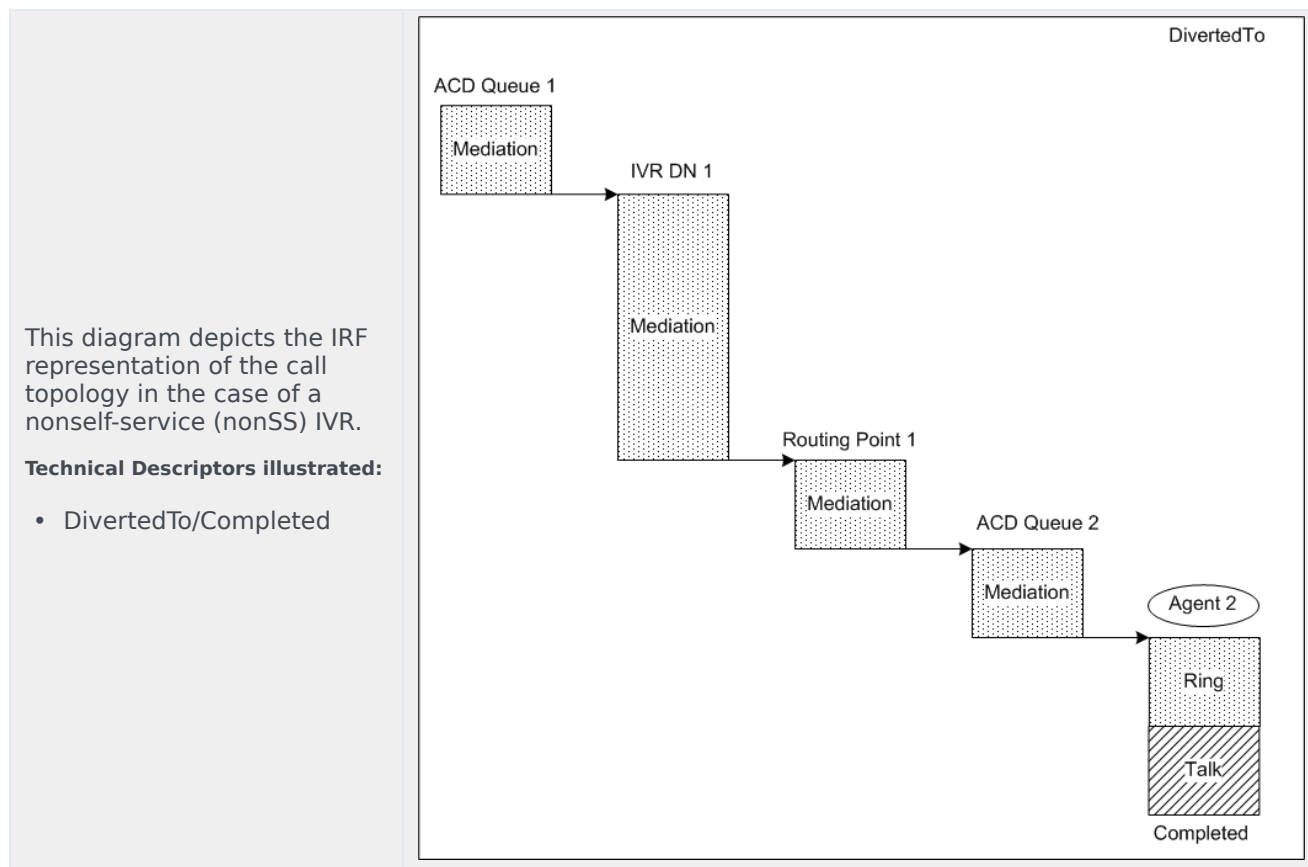

Inbound call — Routing Point routes to agent

This call topology shows the outcome of a call that is routed directly to an agent. The call arrives at an ACD queue and is diverted to an IVR DN. The IVR then transfers the call to a Routing Point, which routes the call to an agent. The following diagrams illustrate the outcomes for:

- Self-service IVR
- Nonself-service IVR

Routing Point routes to agent (self-service IVR)

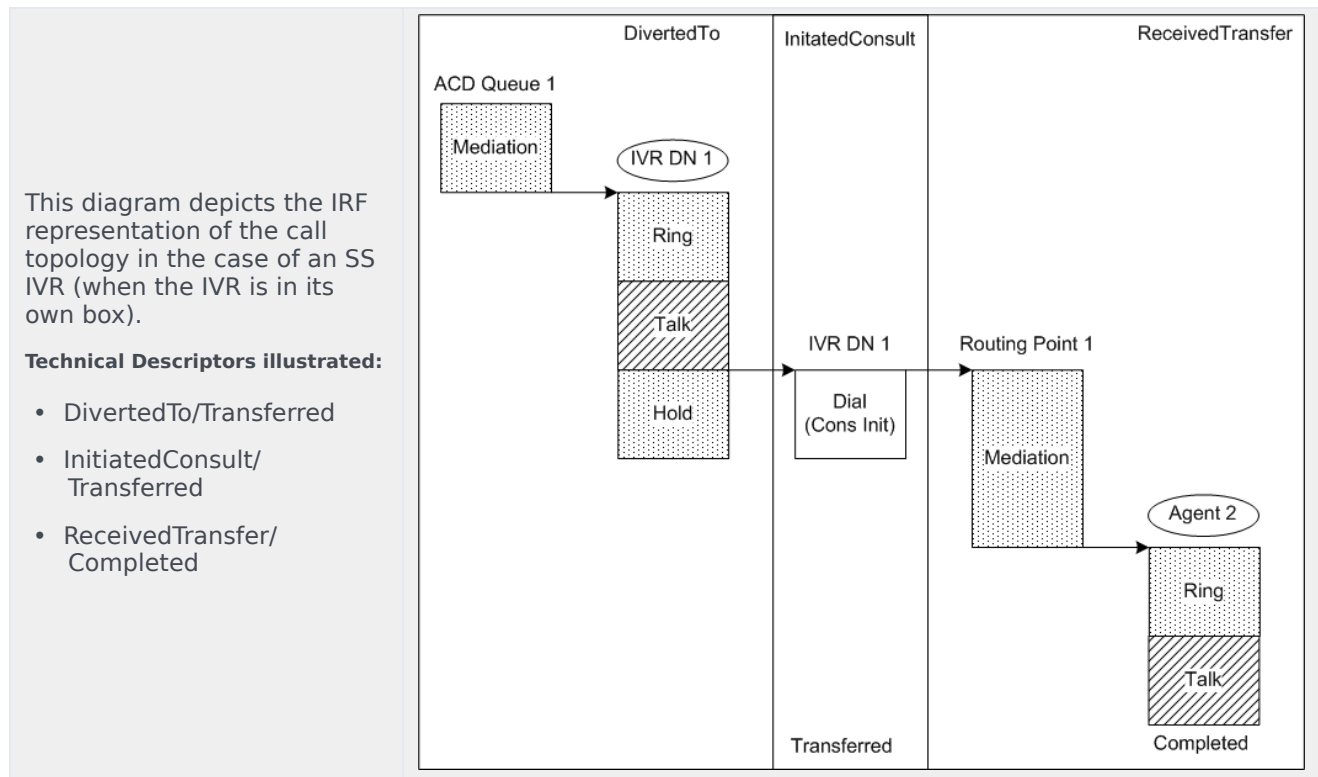

Routing Point routes to agent (nonself-service IVR)

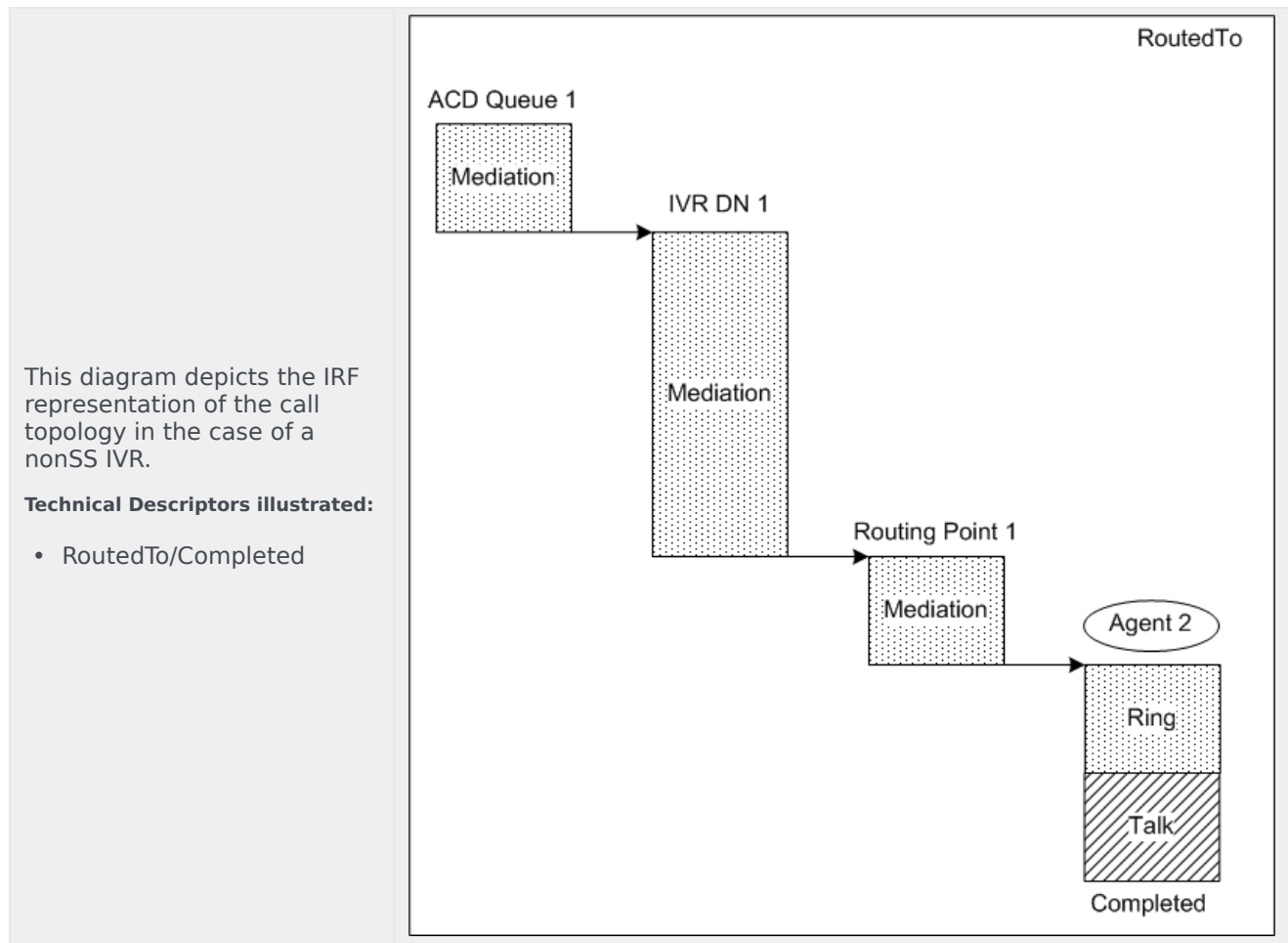

Inbound call to ACD and parallel IVR

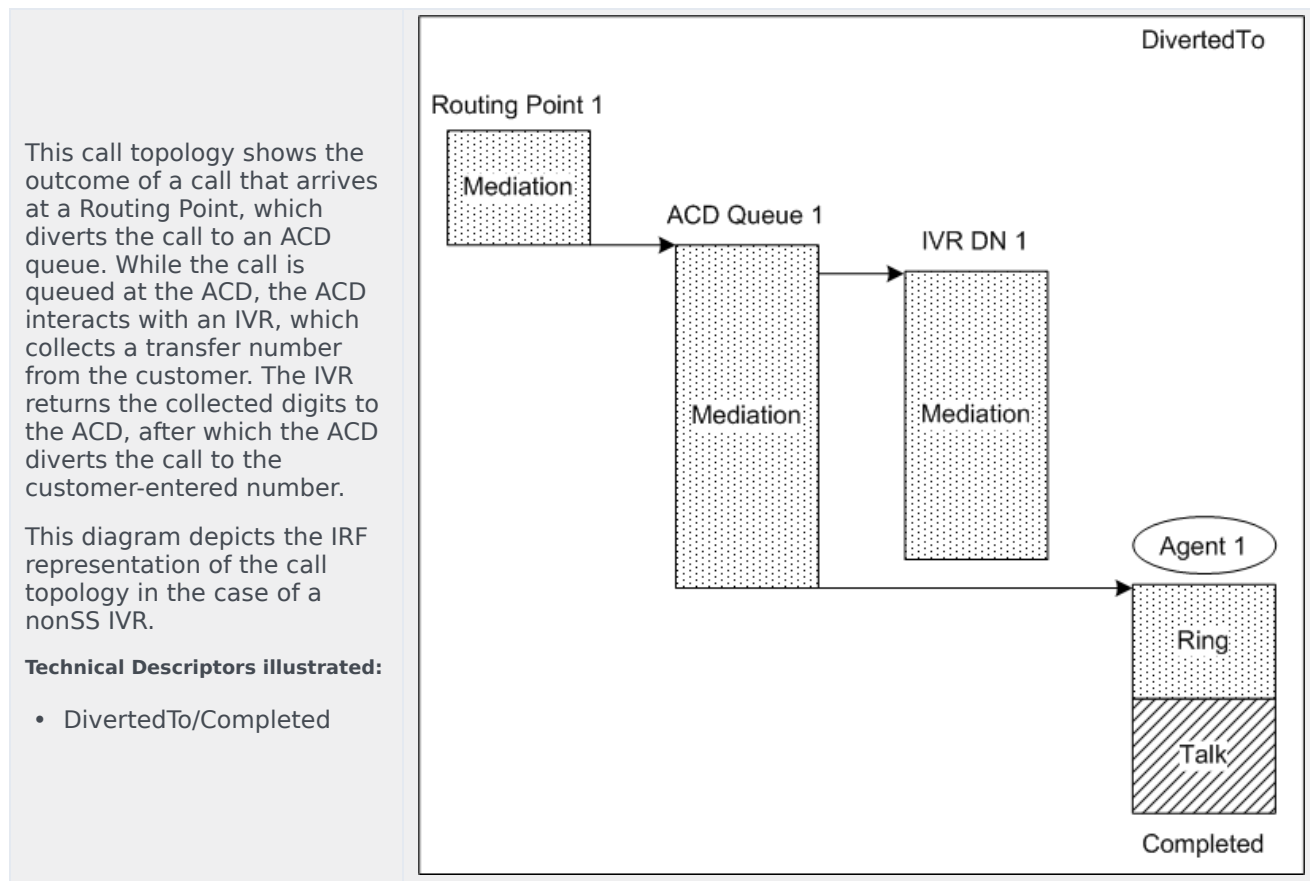

IVR-in-Front-of-Switch Assisted by Universal Routing Call Flows

This page illustrates voice inbound call flows that are available in IVR solutions that use Genesys Universal Routing, where the IVR is deployed in front of the switch.

Voice interactions arrive at an IVR that is visible to the IVR Server's virtual T-Server. Through a Routing Point in the IVR Server's virtual T-Server, the IVR application invokes an Universal Routing strategy. Universal Routing instructs the IVR application to play applications or collect information. Universal Routing uses the collected information to return an appropriate target. The IVR application hook-flash transfers the call to that target.

The following call flows are supported:

- **Inbound interaction — IVR transfers to ACD queue**
- **Inbound interaction — IVR transfers to agent**

Inbound interaction — IVR transfers to ACD queue

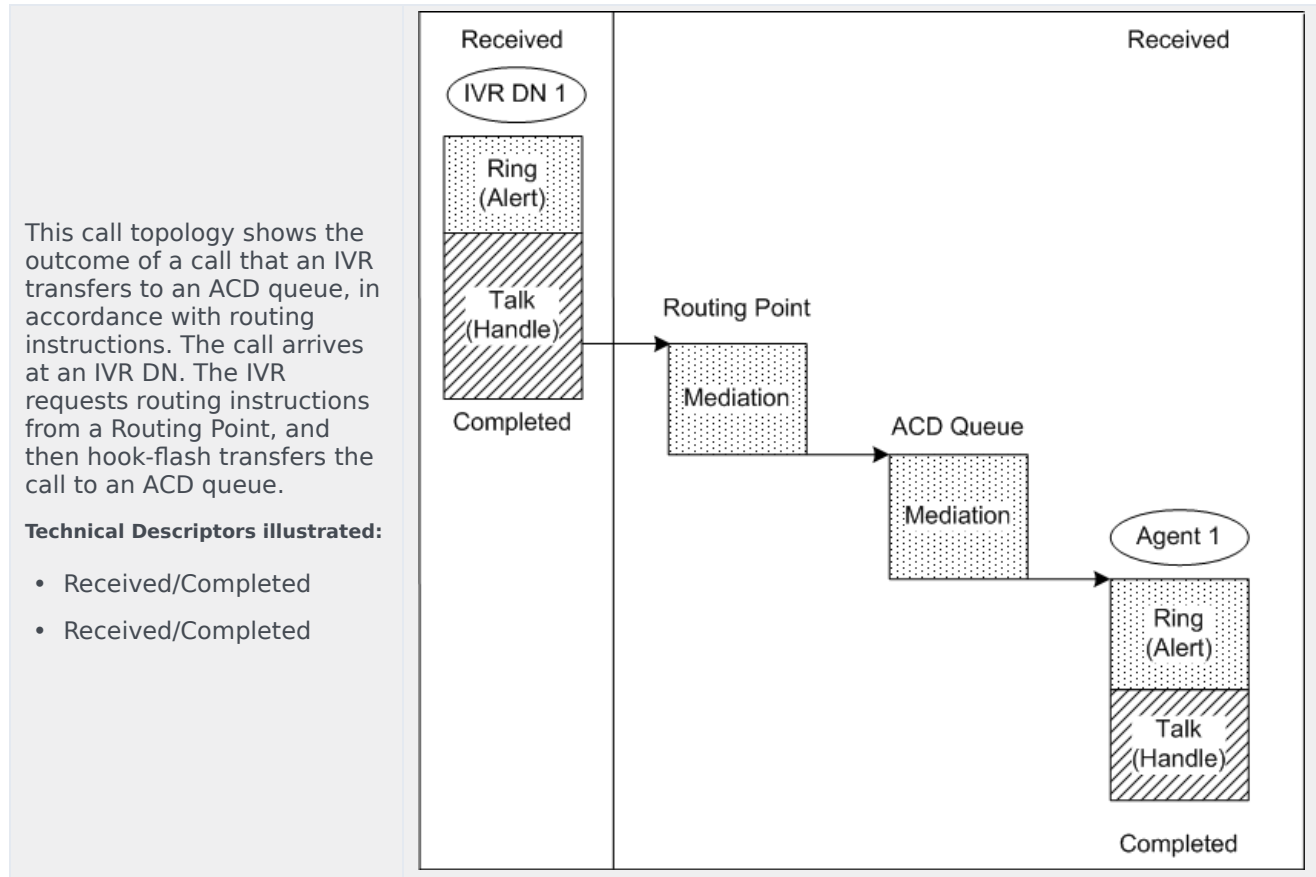

Inbound interaction — IVR transfers to agent

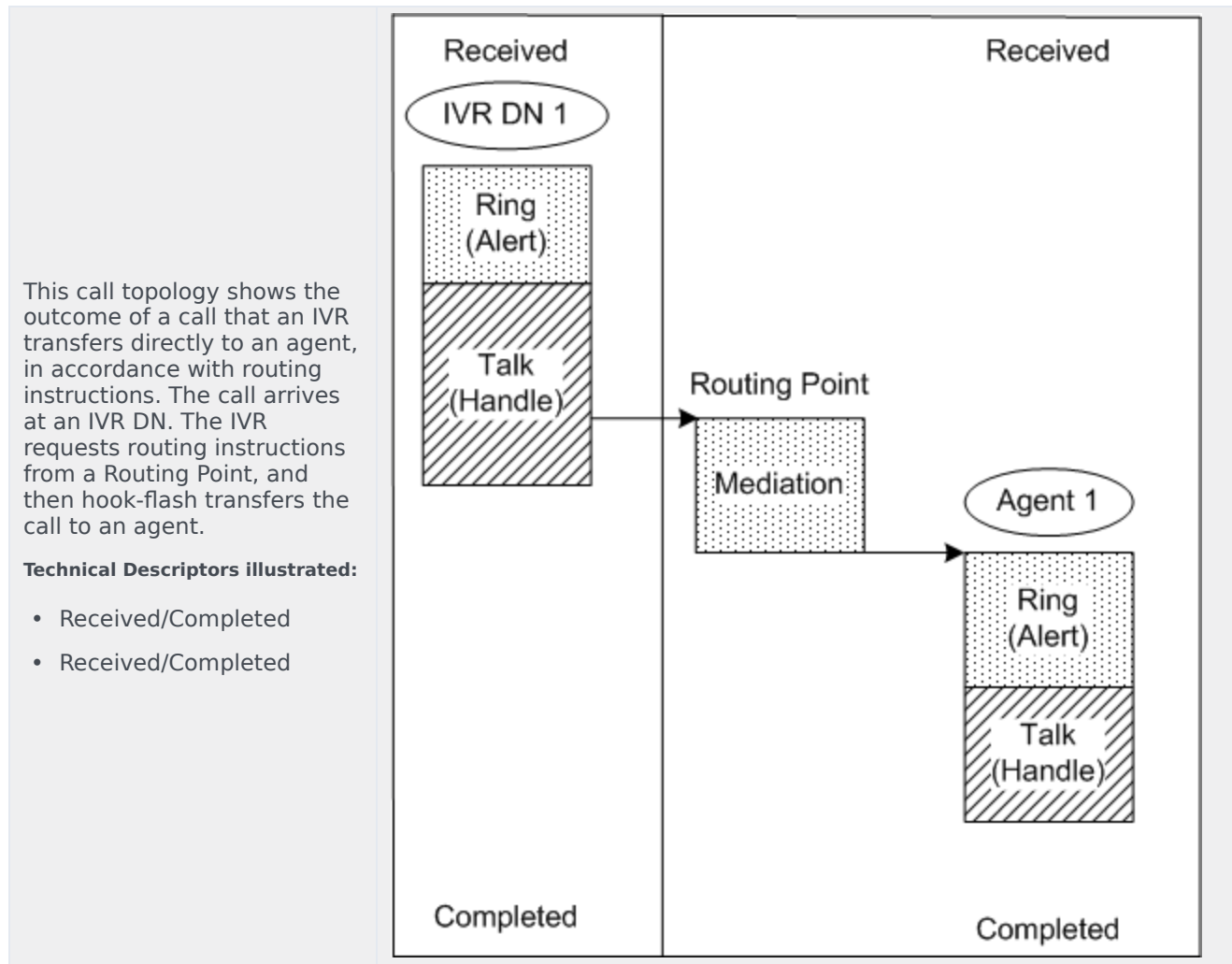

IVR-Behind-Switch Assisted by Universal Routing Call Flows

This page illustrates voice inbound call flows that are available in IVR solutions that use Genesys Universal Routing, where the IVR is deployed behind the switch.

Voice interactions that arrive at the switch are queued to an ACD queue, in which the ACD positions are actually IVR DNs. Through a virtual routing point in the premise T-Server, the IVR application invokes a Universal Routing strategy. Universal Routing instructs the IVR application to play applications or collect information and uses the collected information to return an appropriate target. The IVR application mute transfers the call to that target.

The following call flows are supported:

- [Inbound call flow — IVR transfers to ACD queue](#)
- [Inbound call flow — IVR transfers to agent](#)

Inbound call flow — IVR transfers to ACD queue

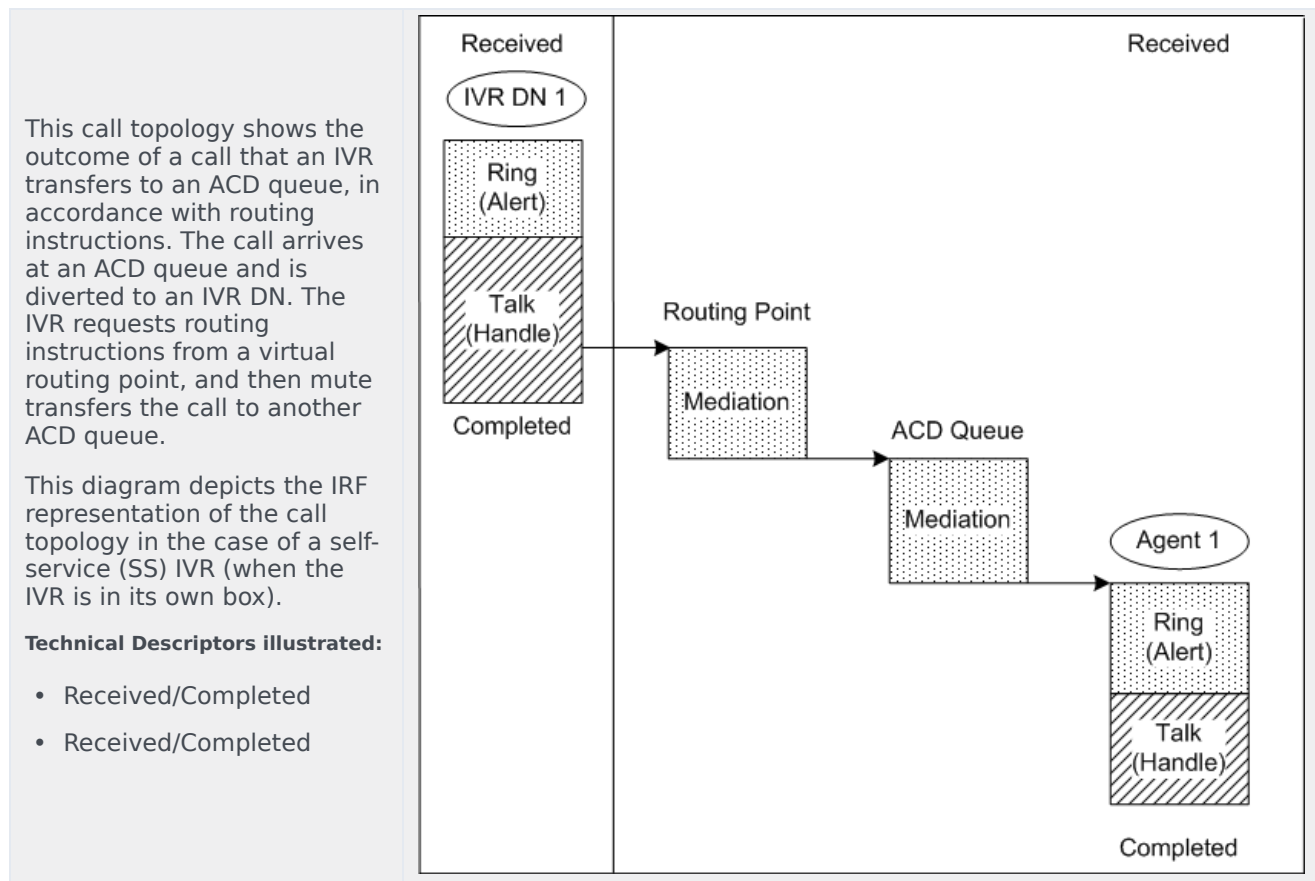

Inbound call flow — IVR transfers to agent

This call topology shows the outcome of a call that an IVR transfers directly to an agent, in accordance with routing instructions. The call arrives at an ACD queue and is diverted to an IVR DN. The IVR requests routing instructions from a virtual routing point, and then mute transfers the call to an agent. The following diagrams illustrate the outcomes for:

- **Self-service IVR**
- **Nonsel-service IVR**

IVR transfers to agent (self-service IVR)

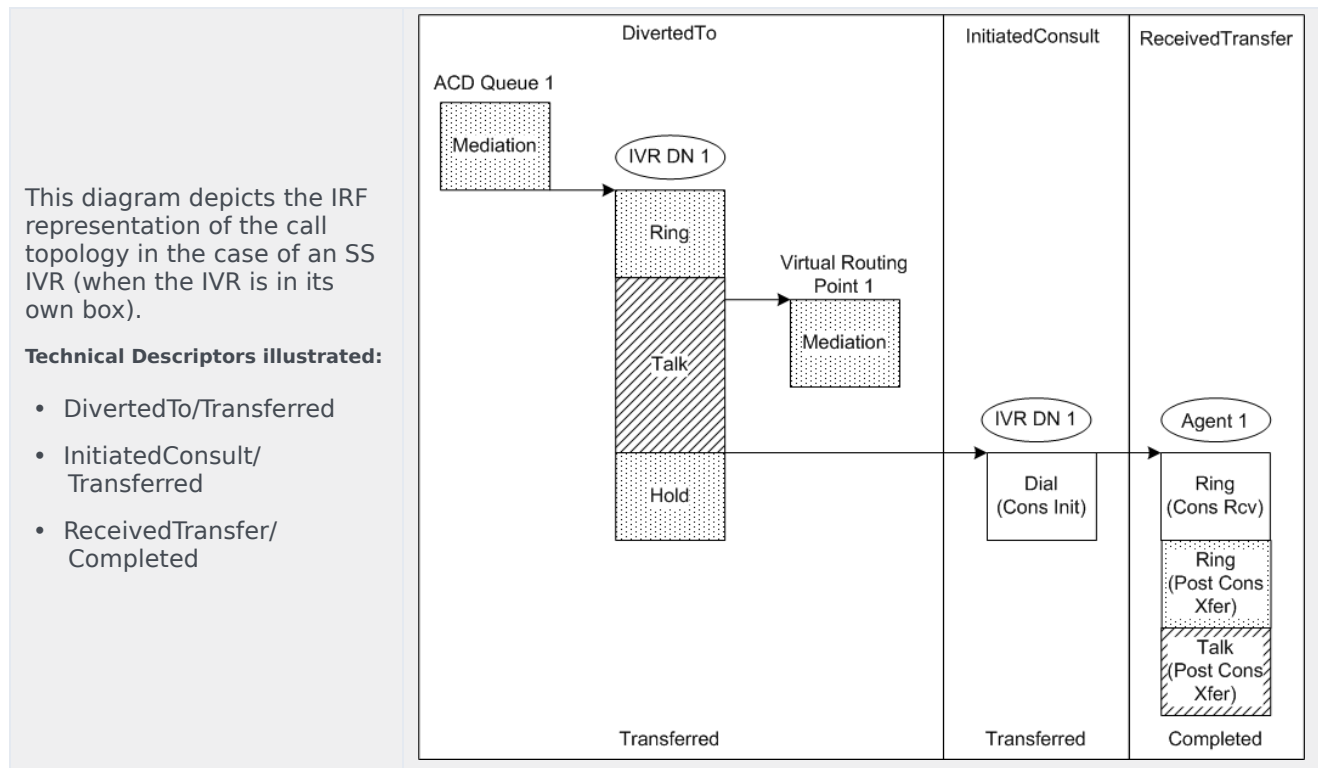

IVR transfers to agent (nonself-service IVR)

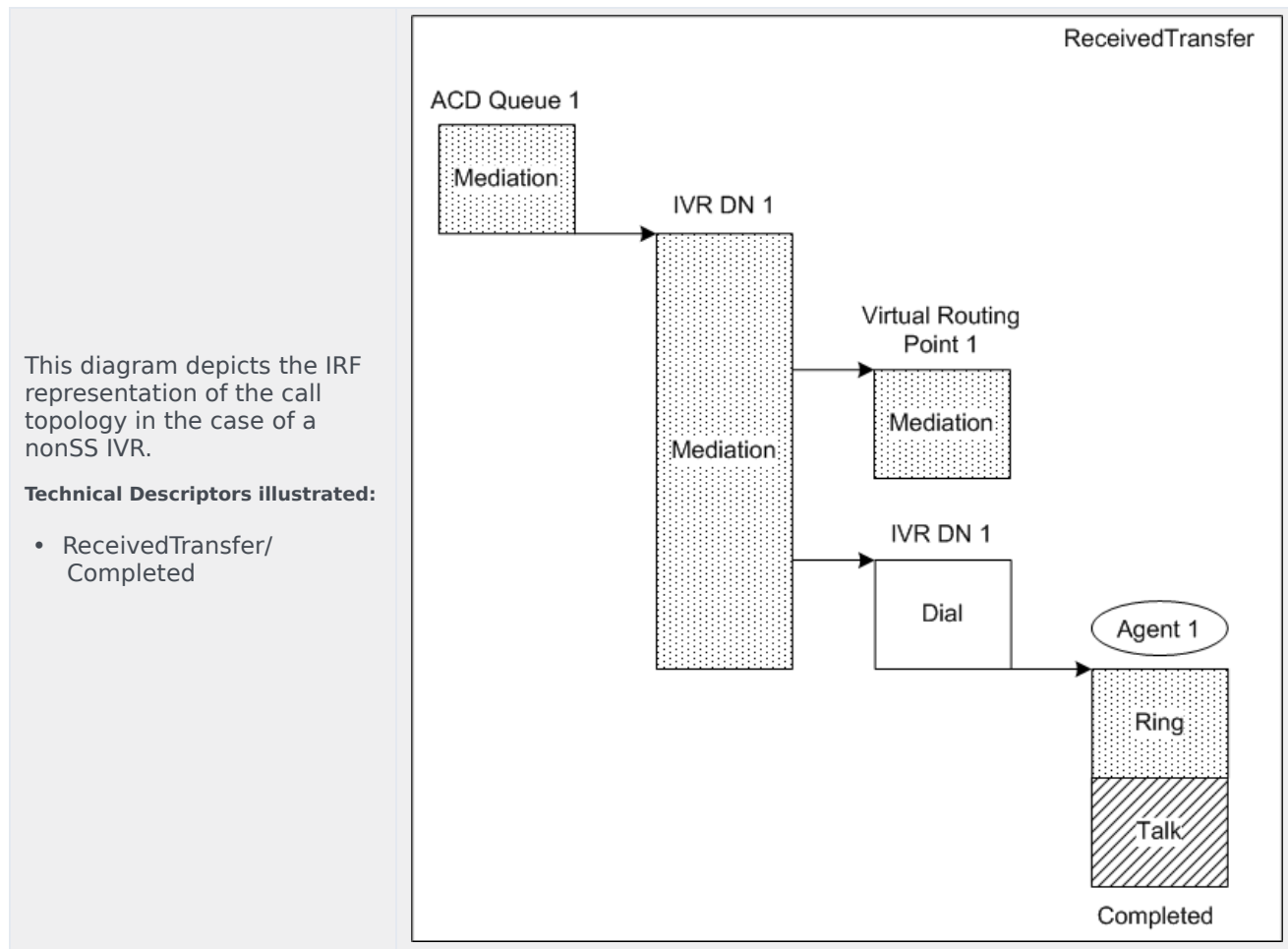

Validated Multimedia Interaction Flows

The [E-Mail Interactions](#) and [Chat Interactions](#) pages describe the recognized, validated multimedia interactions that have been tested and that are supported by Genesys Info Mart for Genesys eServices e-mail and chat. However, Genesys Info Mart supports full processing of any 3rd Party Media interactions, in addition to e-mail and chat interactions.

Use the interaction flows that discuss e-mail as a guide to interactions that do not involve an online session with a customer (offline interactions), and the chat interaction flows as a guide to interactions that do involve an online session with a customer (online interactions).

The interaction flows described in this guide are intended as examples that you can modify for your environment. However, Genesys does not guarantee results for modified interaction flows.

Multimedia diagram conventions

Like the [voice interaction flows](#), the multimedia interaction-flow diagrams represent the resources that participate in interactions and the resources' states. The diagrams use the same conventions as the voice call flow diagrams (see [Diagram Conventions](#)). In addition, the following features are significant for the multimedia interaction-flow diagrams:

- Terms such as *Ring* and *Talk* are used generically. In multimedia interaction flows, these terms indicate the Alerting and Connected conditions.
- For both online and offline interactions, the customer is considered to be present (“talking”) during the whole interaction, except for any consultation portions.
- The resources of interest are handling resources, which are the resources that have the greatest interest for reporting. Primarily, these are agents, but routing strategies that send an Autoresponse are also considered to be handling resources and become the subjects of Interaction Resource Fact (IRF) records. Additionally, when an interaction is abandoned in an Interaction Queue or a Routing Strategy, the resource in which it was abandoned is represented with an IRF entry.
- Strategies are not mediation resources. The diagrams illustrate the use of virtual queues (VQs) to enable time that an interaction spends in a strategy to be reported in a Mediation Segment Fact (MSF) record, as mediation time. Prior to release 8.5.002, if no VQ is defined in a strategy, there will be gaps in the reported mediation time. Starting with release 8.5.002, with a further enhancement in release 8.5.007 (as described in the discussion about [MEDIATION_DURATION](#) on the [Populating Mediation Segments](#) page), Genesys Info Mart can be configured to eliminate gaps in mediation reporting. With the 8.5.007 enhancement, when `show-non-queue-mediation-mm` is set to `true`, Genesys Info Mart provides gapless mediation reporting up to first handling by creating an additional, non-queue MSF to represent time the interaction spent outside an Interaction Queue before being handled. The diagrams do not show the possible non-queue MSF that would be created for the strategy in the illustrated interaction flows. If VQs are used and gapless mediation reporting is enabled in release 8.5.007 or later, the MSF for a VQ will overlap the MSF for the strategy.
- In all cases in which a routing strategy routes an interaction to an agent, the diagrams show the interaction flow beginning in mediation, while the interaction waits in Interaction Queue 1. When Strategy 1 attempts to find a routing target, the strategy keeps the interaction in VQ1 (another mediation). [Transfer from agent to agent through a queue with multiple VQs](#) shows the effect of more

complicated routing strategies in which there are multiple parallel and sequential VQs. On the other hand, all the diagrams that end with the e-mail being sent out of the contact center show a strategy that is not being used for routing purposes and, therefore, for which VQs do not apply.

- The diagrams show VQ time and strategy time as identical, which is always the case when `adjust-vq-time-by-strategy-time=true`. This means that mediation duration includes time that the interaction spent in the strategy but outside the VQ, and there are no gaps in the mediation time.
- Except where otherwise indicated, the diagrams assume that Genesys Info Mart has been configured to populate Interaction Queue activity in the MSF table (`populate-mm-ixnqueue-facts = true`). MSFs for Interaction Queue activity have been included in the diagrams for completeness. By default, `populate-mm-ixnqueue-facts=false`.
- Given the focus and purpose of this guide, the e-mail diagrams for interaction flows that end when the e-mail is sent out of the contact center show the e-mail being sent to an Interaction Queue (named Outbound Queue), from which a strategy (named Outbound Strategy) sends the e-mail to the customer. However, more complicated scenarios are possible, in which case the reported technical result might be different. For example, if the outbound e-mail is first sent to a supervisor for a quality review, there will be additional mediation, and the technical result in the IRF for the handling agent will be Transferred instead of Completed.

On the other hand, if your business processes use stop-interaction queues — as defined by the `stop-ixn-queues` configuration option — to handle stopping an interaction, placement of an interaction into a stop-ixn queue means Genesys Info Mart considers the interaction to be terminated: The technical result reported for the handling agent that placed the interaction in the stop-ixn-queue will be Completed, and the queue and subsequent strategy activity are not represented in Genesys Info Mart.

E-Mail Interactions

This page illustrates e-mail interaction flows that are available in multimedia deployments.

The e-mail interaction flows on this page describe the recognized, validated multimedia interactions that have been tested and that are supported by Genesys Info Mart for Genesys eServices e-mail. However, Genesys Info Mart supports full processing of any 3rd Party Media interactions, in addition to e-mail and chat interactions.

Use the e-mail interaction flows as a guide to interactions that do not involve an online session with a customer (offline interactions).

The interaction flows described in this guide are intended as examples that you can modify for your environment. However, Genesys does not guarantee results for modified interaction flows.

See [Multimedia diagram conventions](#) and [Diagram Conventions](#) for important information about interpreting the diagrams.

The following call flows are supported:

- [Strategy routes e-mail to agent, and agent replies](#)
- [Agent invited into e-mail interaction, and invitation revoked](#)
- [E-mail interaction handled by a strategy with autoresponse](#)
- [Agent transfers e-mail directly to another agent](#)
- [Agent's attempt to transfer e-mail directly to another agent fails](#)
- [Transfer of e-mail from agent to agent through a queue](#)
- [Unsuccessful transfer from agent to agent through a queue](#)
- [Transfer from agent to agent through a queue with multiple VQs](#)
- [Agent consults to another agent before sending reply — non-blocking](#)
- [Agent consults to another agent before sending reply — blocking](#)
- [Agent unsuccessfully consults to another agent before sending reply](#)
- [Agent saves draft reply before sending \(mediation\)](#)
- [Agent pulls e-mail from an Interaction Queue or Workbin](#)
- [Agent saves draft reply before sending \(hold\)](#)
- [Agent sends outbound e-mail](#)
- [Multipart reply](#)
- [Multipart e-mail reply with unsent reply](#)
- [Routing strategy repeatedly fails to find a target](#)

Strategy routes e-mail to agent, and agent replies

The diagram shows the outcome of an e-mail interaction that a routing strategy routes to Agent 1, who accepts the invitation (IRF1).

Agent 1 creates an outbound reply e-mail (IRF2), closing the original inbound e-mail. The outbound e-mail is placed into Outbound Queue, from which Outbound Strategy sends it out of the contact center to the customer.

Technical Descriptors illustrated:

- RoutedTo/Completed
- Initiated/Completed

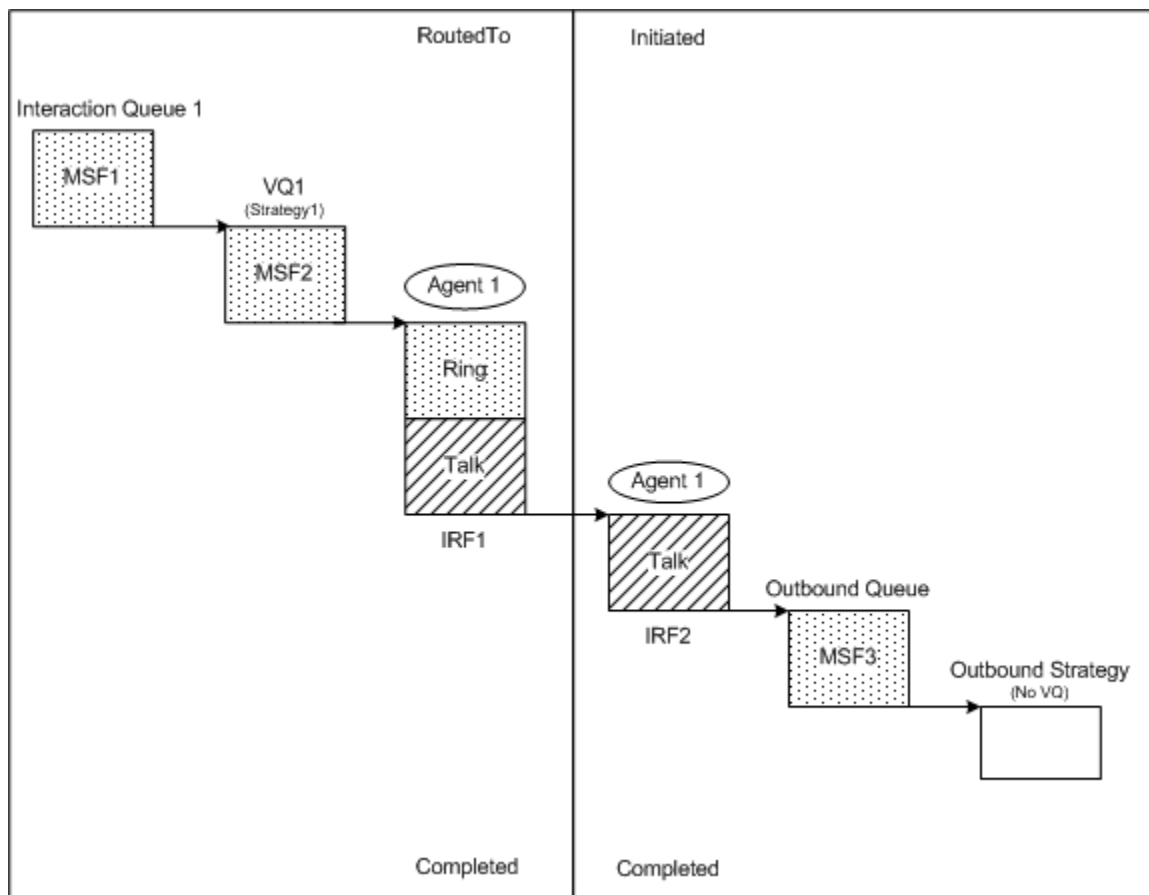

Agent invited into e-mail interaction, and invitation revoked

The diagram shows the outcome when an e-mail interaction is offered to an agent by a routing strategy, but the agent does not accept the invitation. The e-mail interaction is returned to the interaction queue so that it can be re-evaluated.

Important

When a routing strategy routes to an agent, the strategy is removed from the interaction as soon as the agent is invited into that interaction. In other words, the routing is complete as soon as the agent is invited.

Technical Descriptors illustrated:

- RoutedTo/Redirected [Revoked]

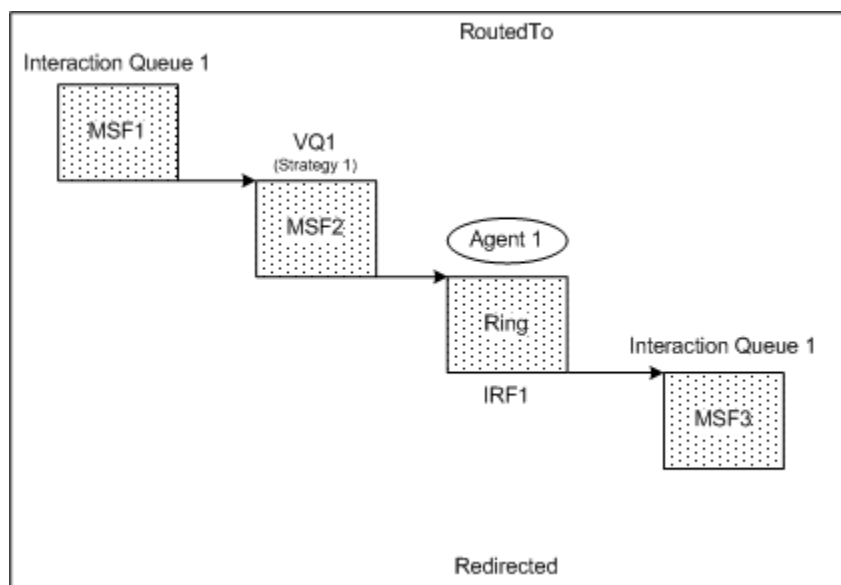

E-mail interaction handled by a strategy with autoresponse

The diagram shows the outcome of an e-mail interaction that a routing strategy determines can be handled with an Autoresponse.

The e-mail is submitted to an inbound interaction queue. The routing strategy pulls the e-mail from the interaction queue and identifies that it can be handled with an Autoresponse, and an autoresponse is generated. Strategy 1 is now considered to be a handling resource. Strategy 1

connected to and stopped the original inbound interaction, represented in IRF1, and created an outbound Autoresponse reply, which is represented in IRF2. The time that Strategy 1 is connected to each e-mail is represented as "Talk" time. Outbound Queue and Outbound Strategy represent the processing that occurs when the e-mail is sent outside the contact center.

The diagram illustrates Genesys Info Mart reporting in releases earlier than 8.5.003 when the `populate-mm-ixnqueue-facts` configuration option is set to `false`. Starting with release 8.5.003, Genesys Info Mart always creates an MSF record for the first Interaction Queue that an inbound interaction enters before first handling, regardless of the value of the **populate-mm-ixnqueue-facts** option.

Technical Descriptors illustrated:

- Puller/Completed
- Initiated/Completed

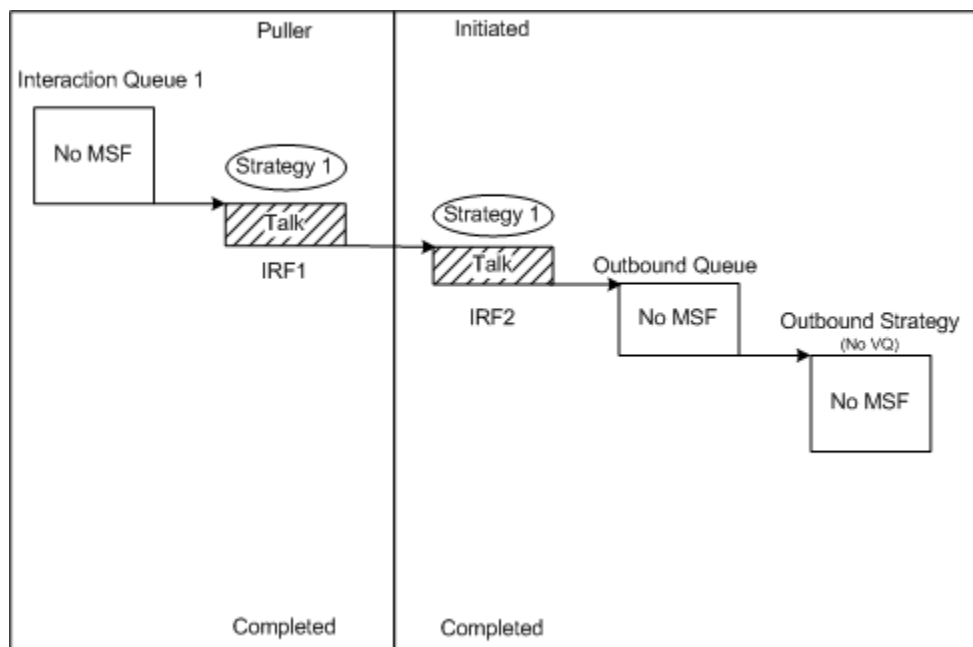

Agent transfers e-mail directly to another agent

The diagram shows the outcome of an e-mail interaction that is routed to an agent, who transfers the e-mail to another agent, who replies to the e-mail.

Agent 1 (IRF1) transfers an inbound interaction to Agent 2. Agent 2 stops the original inbound interaction while creating an outbound reply (IRF2 and IRF3). The outbound reply is placed into Outbound Queue, from which Outbound Strategy sends it out of the contact center to the customer. When an agent directly invites another agent into an interaction, the original agent remains in the

interaction until the target agent accepts the invitation. In the case of a transfer, the transfer does not occur until the target agent accepts the invitation.

Important

In this scenario, the original inbound e-mail is transferred. The interaction flow showing a failed transfer attempt (**Agent's attempt to transfer e-mail directly to another agent fails**) presents a partial variation on this scenario, in which Agent 1 creates an outbound reply and attempts to transfer the reply to Agent 2.

Technical Descriptors illustrated:

- RoutedTo/Transferred
- ReceivedTransfer/Completed
- Initiated/Completed

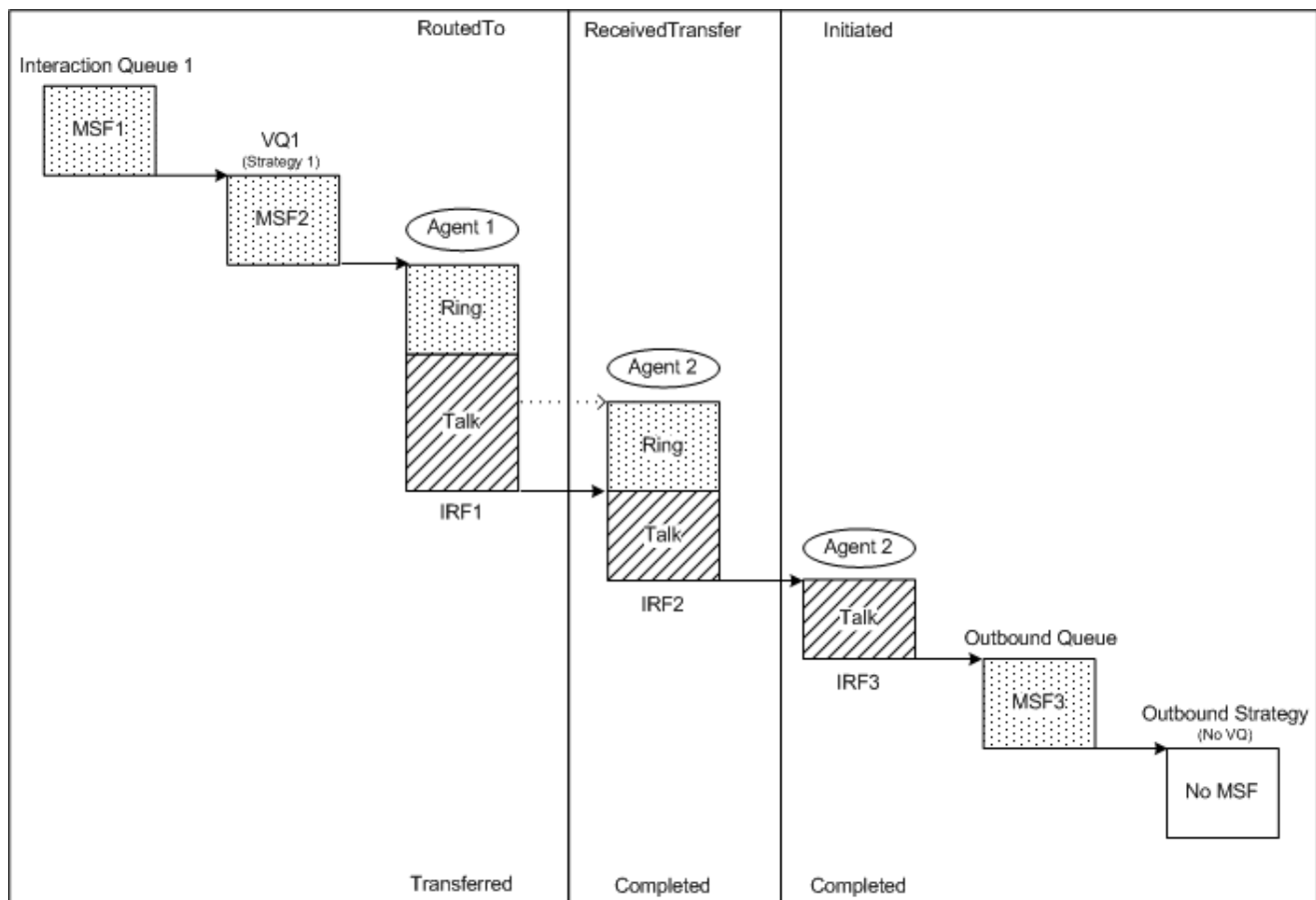

Agent's attempt to transfer e-mail directly to another agent fails

The diagram shows the outcome of an unsuccessful attempt to transfer an e-mail to another agent.

The interaction is routed to Agent 1. Agent 1 accepts the inbound e-mail (IRF1) and creates an outbound reply (IRF2), closing the original inbound e-mail. Agent 1 works on this reply and then attempts to transfer this reply to Agent 2, for Agent 2 to complete the reply (IRF3). Agent 2 does not accept the invitation into the interaction. Agent 1 remains in the interaction during the attempt to transfer. In this case, since Agent 2 was not available, Agent 1 completes the reply and places it into Outbound Queue, from which Outbound Strategy sends it out of the contact center to the customer.

Technical Descriptors illustrated:

- RoutedTo/Completed
- Initiated/Completed
- ReceivedTransfer/Abandoned [Revoked]

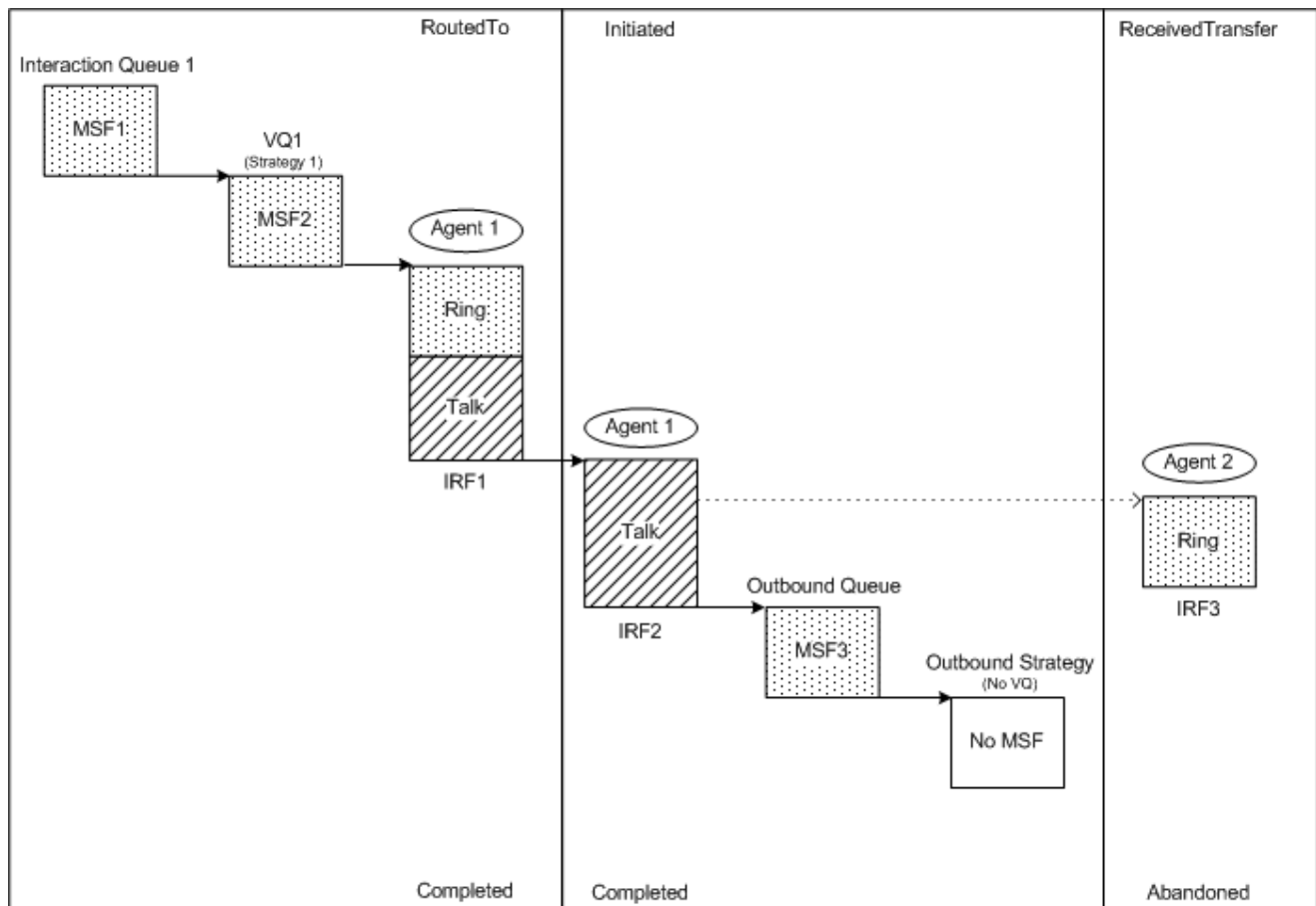

Transfer of e-mail from agent to agent through a queue

The diagram shows the outcome of an e-mail interaction that is routed to an agent, who transfers the e-mail through a queue to another agent, who replies to the e-mail.

Agent 1 transfers an inbound interaction through Interaction Queue 2 to Agent 2 (IRF2). Agent 2 stops the original inbound interaction while creating an outbound reply (IRF2 and IRF3). The outbound reply is placed into Outbound Queue, from which Outbound Strategy sends it out of the contact center to the customer.

Important

In this scenario, the original inbound e-mail is transferred. The interaction flow showing a failed transfer attempt (**Agent's attempt to transfer e-mail directly to another agent fails**) presents a partial variation on this scenario, in which Agent 1 creates an outbound reply and attempts to transfer the reply to Agent 2.

Technical Descriptors illustrated:

- RoutedTo/Transferred
- ReceivedTransfer/Completed
- Initiated/Completed

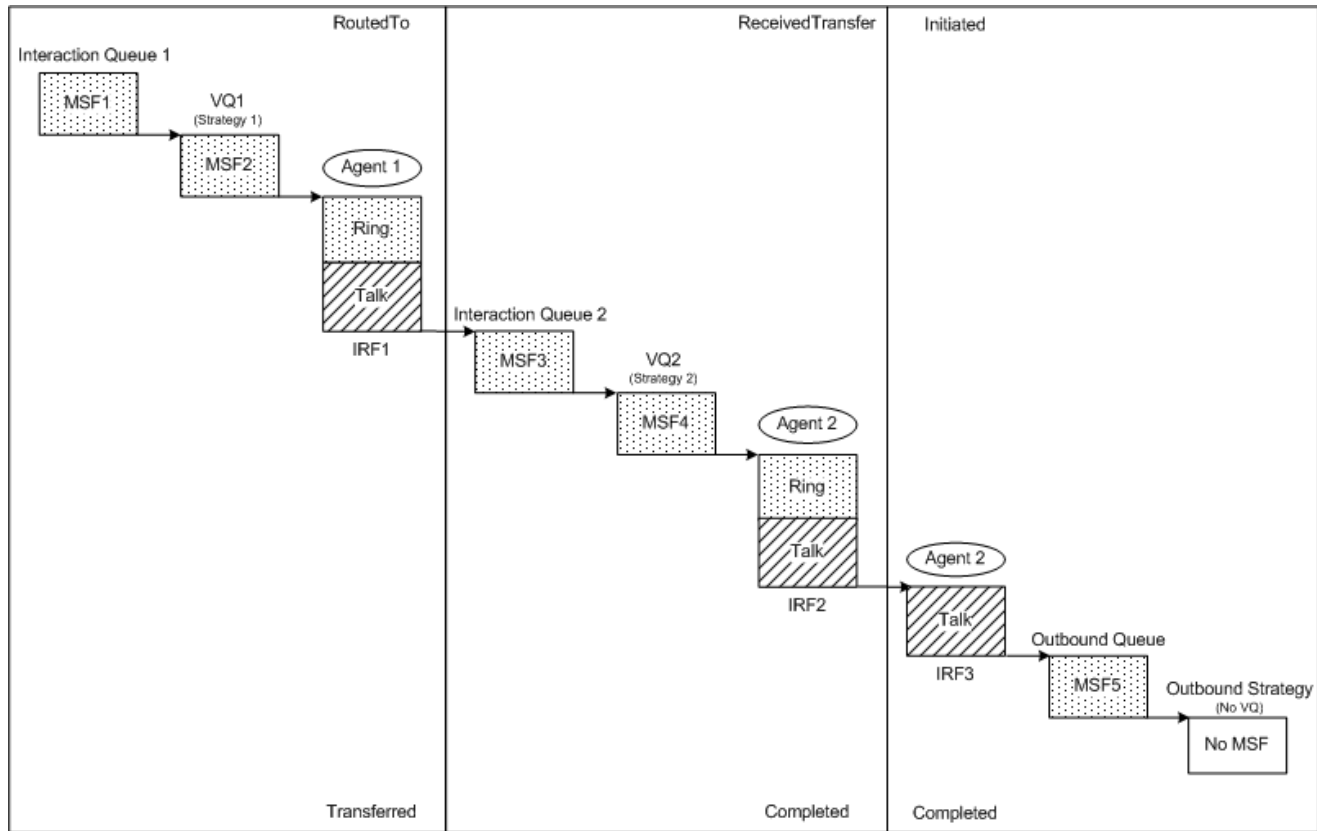

Unsuccessful transfer from agent to agent through a queue

The diagram shows the outcome of an unsuccessful attempt to transfer an e-mail interaction from one agent to another agent through a queue.

The interaction is routed to Agent 1. Agent 1 accepts the inbound e-mail (IRF1) and creates an outbound reply, closing the original inbound e-mail (IRF2). Agent 1 works on this reply, and then attempts to transfer the reply interaction through Interaction Queue 2 to another agent for continued processing. The reply interaction is routed from the queue to Agent 2 (IRF3). Agent 2 does not accept the invitation, and this revoked invitation is returned to Interaction Queue 2, so that another routing target can be found.

Technical Descriptors illustrated:

- RoutedTo/Completed
- Initiated/Transferred
- ReceivedTransfer/Redirected [Revoked]

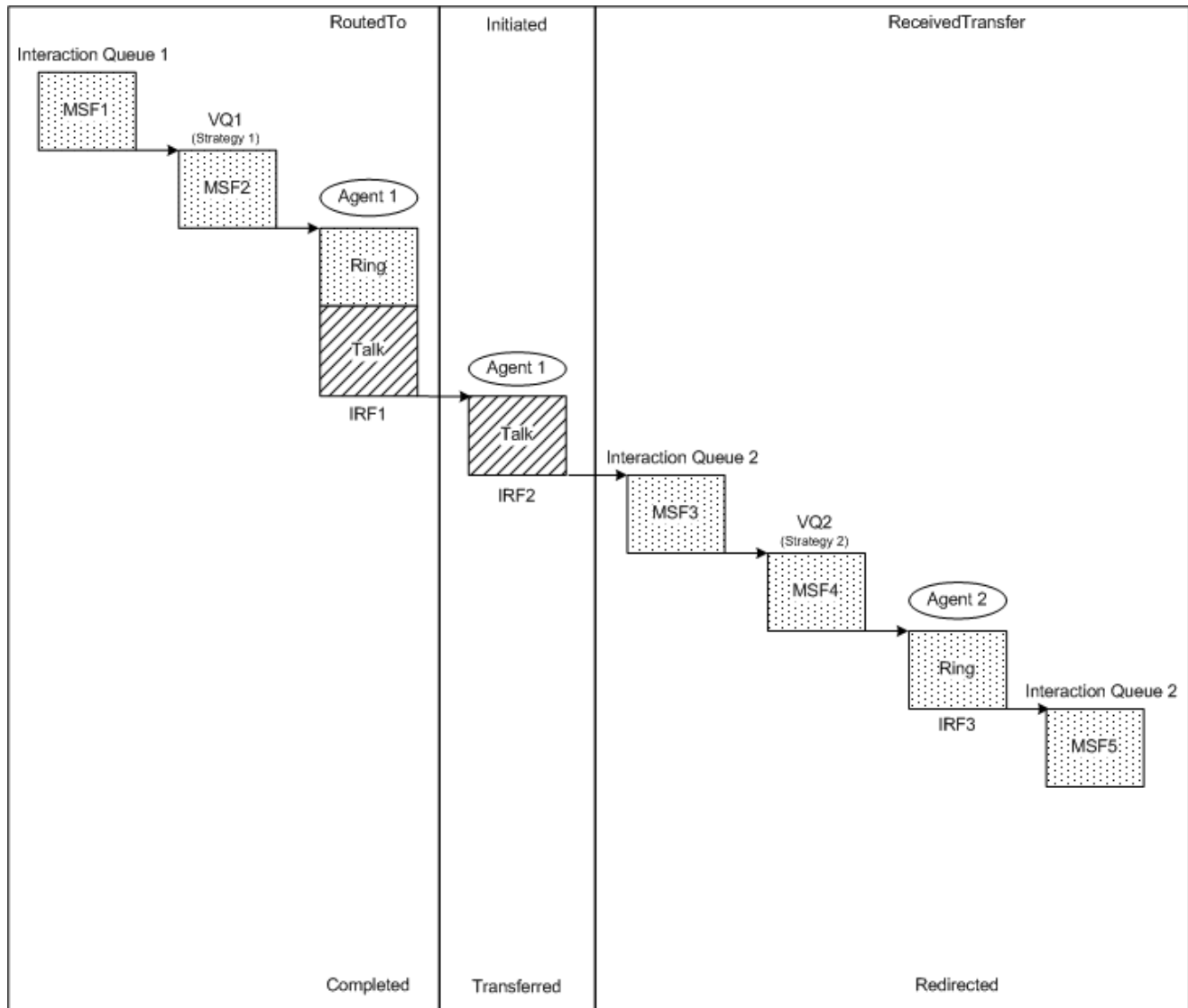

Transfer from agent to agent through a queue with multiple VQs

The diagram shows the outcome of an inbound e-mail interaction that is routed to an agent, who transfers the e-mail through a queue to another agent, when the routing strategies contain several VQs. In this example, Strategy 1 contains three parallel VQs (VQ1, VQ2, VQ3) and Strategy 2 contains three sequential VQs (VQ4, VQ5, VQ6).

Strategy 1 takes the e-mail from Interaction Queue 1 and places the e-mail simultaneously in all three VQs that are associated with the strategy. Strategy1 finds a routing target through VQ1 and routes the interaction to the target (Agent 1).

Agent 1 handles the e-mail (IRF1) and then decides to transfer it to another agent through Interaction Queue 2, for continued processing. Strategy 2 takes the e-mail from Interaction Queue 2 and places it in VQ4. When Strategy 2 does not find an available agent who is associated with VQ4, the strategy places the e-mail in VQ5, where it finds an available agent (Agent 2). The strategy routes the e-mail to Agent 2 (IRF2). Because the interaction did not reach the third VQ that is associated with Strategy 2, there is no MSF for VQ6. Given the focus of this example, the diagram does not show the continued processing after Agent 2 gets control of the interaction; the technical result for IRF2 depends on what Agent 2 does with the interaction.

The diagram illustrates Genesys Info Mart reporting in releases earlier than 8.5.003 when the populate-mm-ixnqueue-facts configuration option is set to false. Starting with release 8.5.003, Genesys Info Mart always creates an MSF record for the first Interaction Queue that an inbound interaction enters, regardless of the value of the **populate-mm-ixnqueue-facts** option.

Technical Descriptors illustrated:

- RoutedTo/Transferred
- ReceivedTransfer/depends on subsequent activity

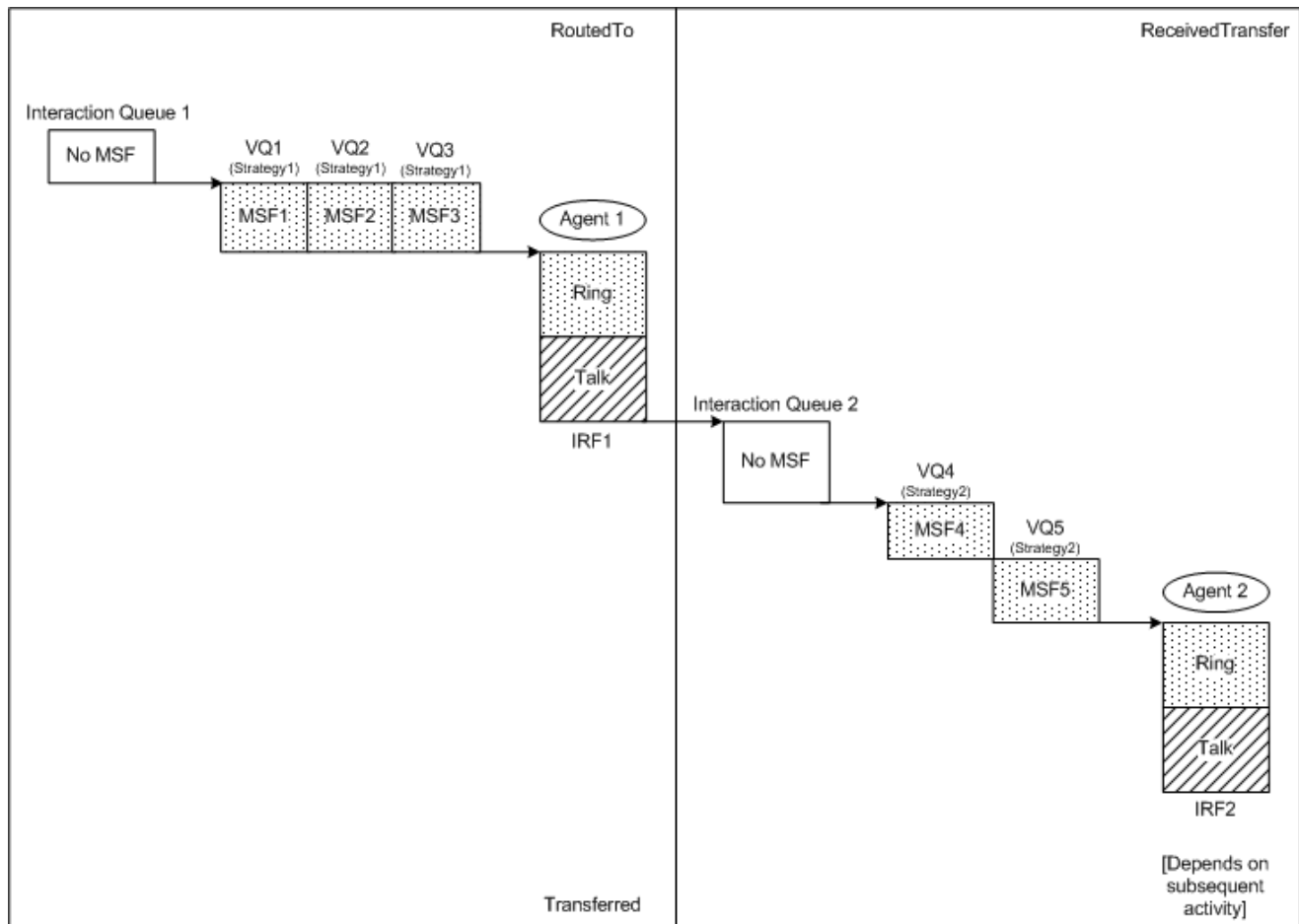

Agent consults to another agent before sending reply — non-blocking

The diagram shows an agent consulting with another agent before sending a reply, when the first agent continues to work on the reply during the consultation period.

The interaction is routed to Agent 1. Agent 1 accepts the inbound e-mail (IRF1) and creates an outbound reply (IRF2), closing the original inbound e-mail. Agent 1 initiates a Consult interaction and transfers it to Agent 2 (IRF3). Agent 2 accepts the Consult interaction (IRF4) and initiates a Consult Reply interaction (IRF5). In a typical Consult scenario, the Consult Reply is placed into Agent 1's Collaboration Workbin. The Consult Reply typically remains in the workbin for the life of the entire interaction, enabling the Consult Reply to be viewed at any time during the processing of the interaction and making it available for viewing by another agent, if Agent 1 transfers ownership of this interaction to another agent. The outbound reply is placed into Outbound Queue, from which Outbound Strategy sends it out of the contact center to the customer.

By placing the Consult Reply in Agent 1's Collaboration Workbin, Agent 2 transfers the Consult Reply back to Agent 1. In a common scenario, the Consult Reply remains in the Collaboration Workbin for the remainder of the interaction, until it is cleaned up when the interaction ends. At that time, a new IRF row (not shown) is added, to show the Consult Reply being pulled from the workbin and Completed. The "Talk" boxes in the Consult portion of the diagram are not shaded, because the customer is not considered to be present during offline consultations.

Technical Descriptors illustrated:

- RoutedTo/Completed
- Initiated/Completed
- InitiatedConsult/Transferred
- ReceivedConsult/Completed
- ReceivedConsult/Transferred

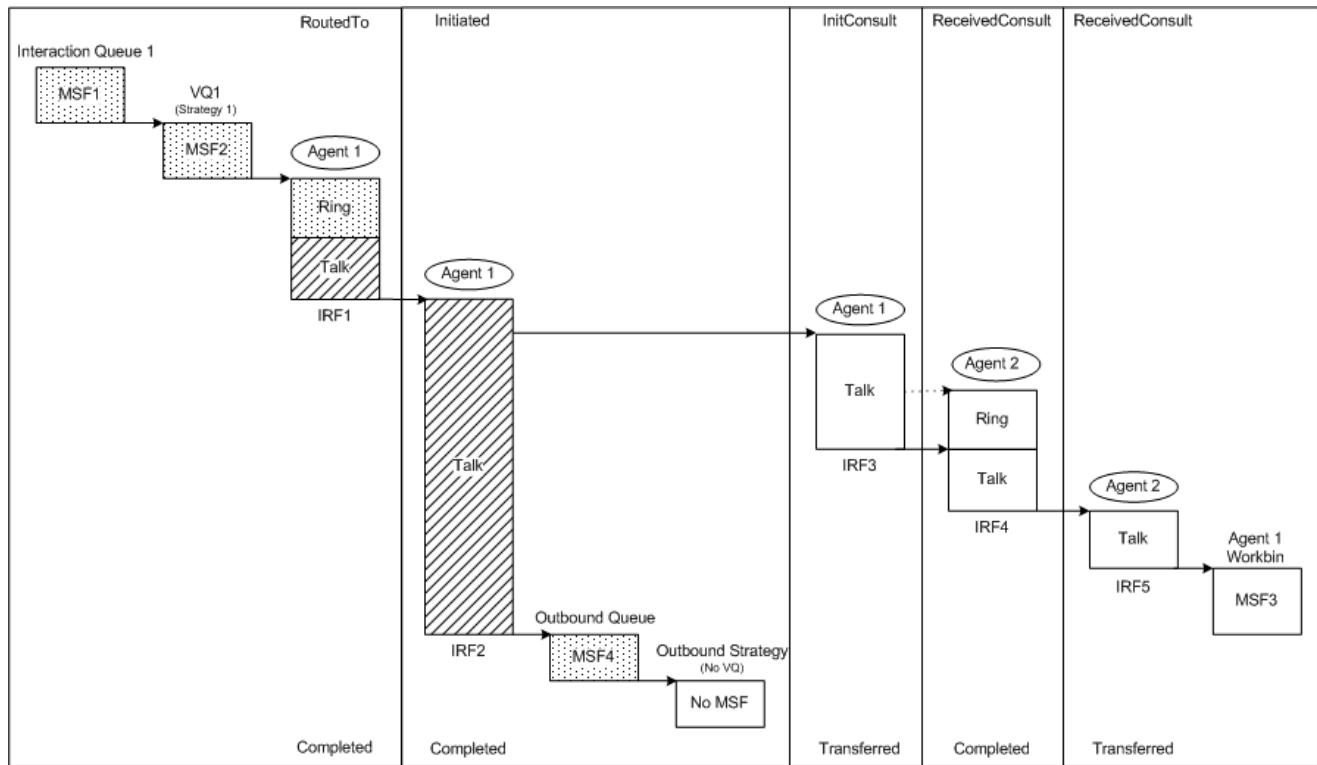

Agent consults to another agent before sending reply — blocking

The diagram shows an agent consulting with another agent before sending a reply, when the first agent suspends work on the reply until the consultation response is received.

The interaction is routed to Agent 1. Agent 1 accepts the inbound e-mail (IRF1) and creates an outbound reply, closing the original inbound e-mail (IRF2). Agent 1 initiates a Consult interaction and transfers it to Agent 2 (IRF3). In the meantime, Agent 1 suspends work on the outbound reply and places it in a Draft Workbin (MSF3), until the results of Agent 2’s collaboration are available. Agent 2 accepts the Consult interaction (IRF4) and initiates a Consult Reply interaction (IRF5). After working on the Consult Reply, Agent 2 places it in Agent 1’s Collaboration Workbin (MSF4), where it typically remains for the remaining life of the interaction. Agent 1 retrieves the suspended outbound reply from the Draft Workbin and completes the reply (IRF6).

The outbound reply is placed into Outbound Queue, from which Outbound Strategy sends it out of the contact center to the customer.

For the time that the interaction is in Agent 1’s Draft Workbin, the diagram illustrates the situation when workbin time is considered to be mediation (`populate-workbin-as-hold=false`). **Agent saves draft reply before sending (hold)** shows the flow for this portion of the interaction when the workbin time is considered to be hold.

By placing the Consult Reply in Agent 1's Collaboration Workbin, Agent 2 transfers the Consult Reply back to Agent 1. In a common scenario, the Consult Reply remains in the Collaboration Workbin for the remainder of the interaction, until it is cleaned up when the interaction ends. At that time, a new IRF row (not shown) is added, to show the Consult Reply being pulled from the workbin and Completed.

The "Talk" boxes in the Consult portion of the diagram are not shaded, because the customer is not considered to be present during offline consultations.

Technical Descriptors illustrated:

- RoutedTo/Completed
- Initiated/Transferred
- InitiatedConsult/Transferred
- ReceivedConsult/Completed
- ReceivedConsult/Transferred
- Puller/Completed

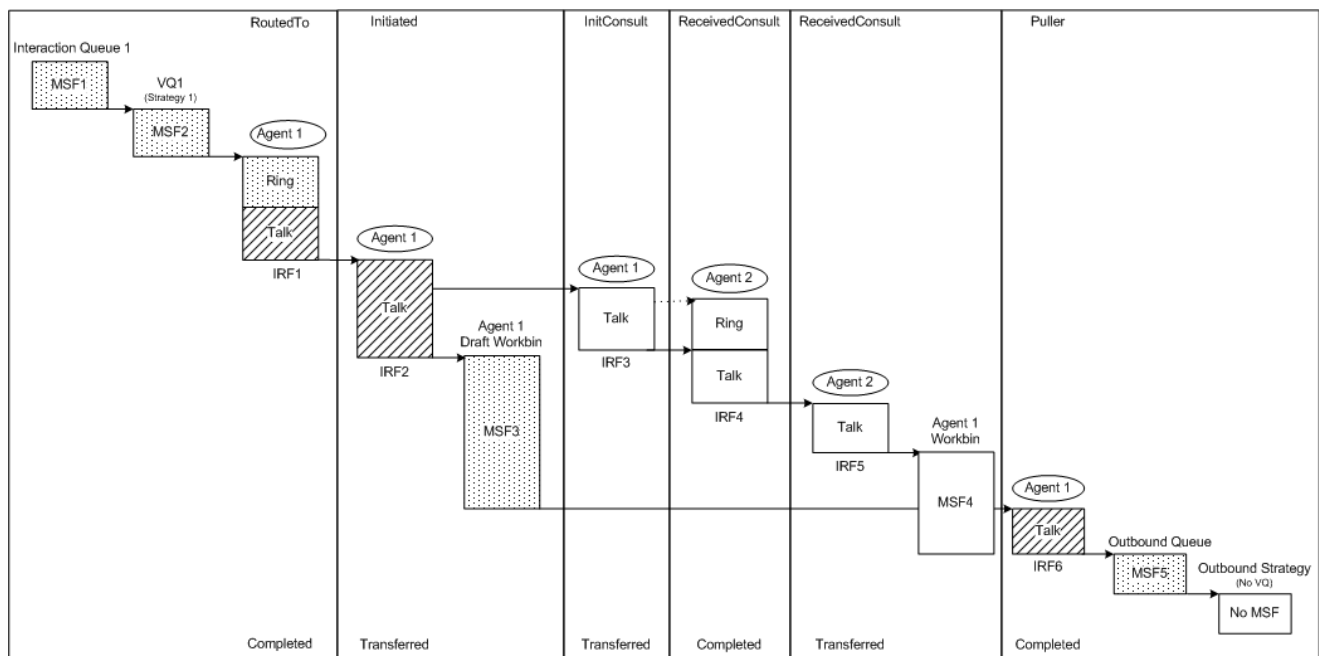

Agent unsuccessfully consults to another agent before sending reply

The diagram shows an agent's unsuccessful attempt to consult with another agent before sending a reply.

The interaction is routed to Agent 1. Agent 1 accepts the inbound e-mail (IRF1) and creates an outbound reply, closing the original inbound e-mail (IRF2). Agent 1 initiates a Consult interaction (IRF3) and transfers it to Agent2. Agent 2 does not accept the invitation into the Consult interaction (IRF4). Agent 1 continues working on the outbound reply (IRF2). The outbound reply is placed into Outbound Queue, from which Outbound Strategy sends it out of the contact center to the customer.

Important

The "Talk" box in the Consult portion of the diagram is not shaded, because the customer is not considered to be present during offline consultations.

Technical Descriptors illustrated:

- RoutedTo/Completed
- Initiated/Completed
- InitiatedConsult/Transferred
- ReceivedConsult/Abandoned [Revoked]

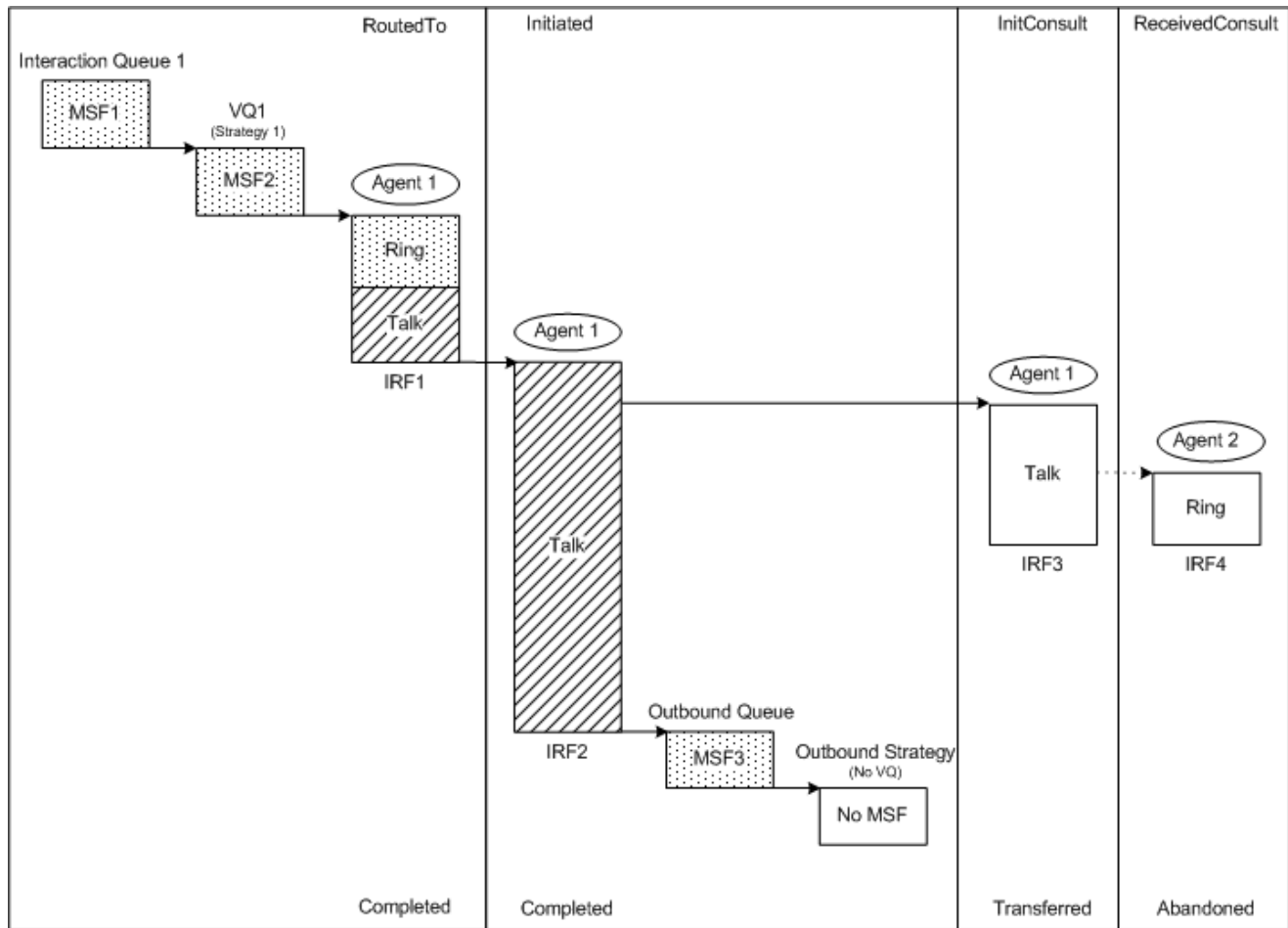

Agent saves draft reply before sending (mediation)

The diagram shows the outcome of an e-mail interaction that is routed to an agent who replies to the e-mail, after first saving an initial version of the reply in a workbin, where the time in the workbin is considered to be mediation.

The interaction is routed to Agent 1. Agent 1 accepts the inbound e-mail (IRF1) and creates an outbound reply, closing the original inbound e-mail (IRF2). Agent 1 saves the outbound reply e-mail in a Draft Workbin. Later, Agent 1 pulls the reply e-mail from the workbin, makes some final modifications to the reply, and then places the reply into Outbound Queue, from which Outbound Strategy sends it out of the contact center to the customer (IRF3).

For the outcome of the same interaction flow when the workbin time is considered to be hold, see [Agent saves draft reply before sending \(hold\)](#).

Technical Descriptors illustrated:

- RoutedTo/Completed

- Initiated/Transferred
- Puller/Completed

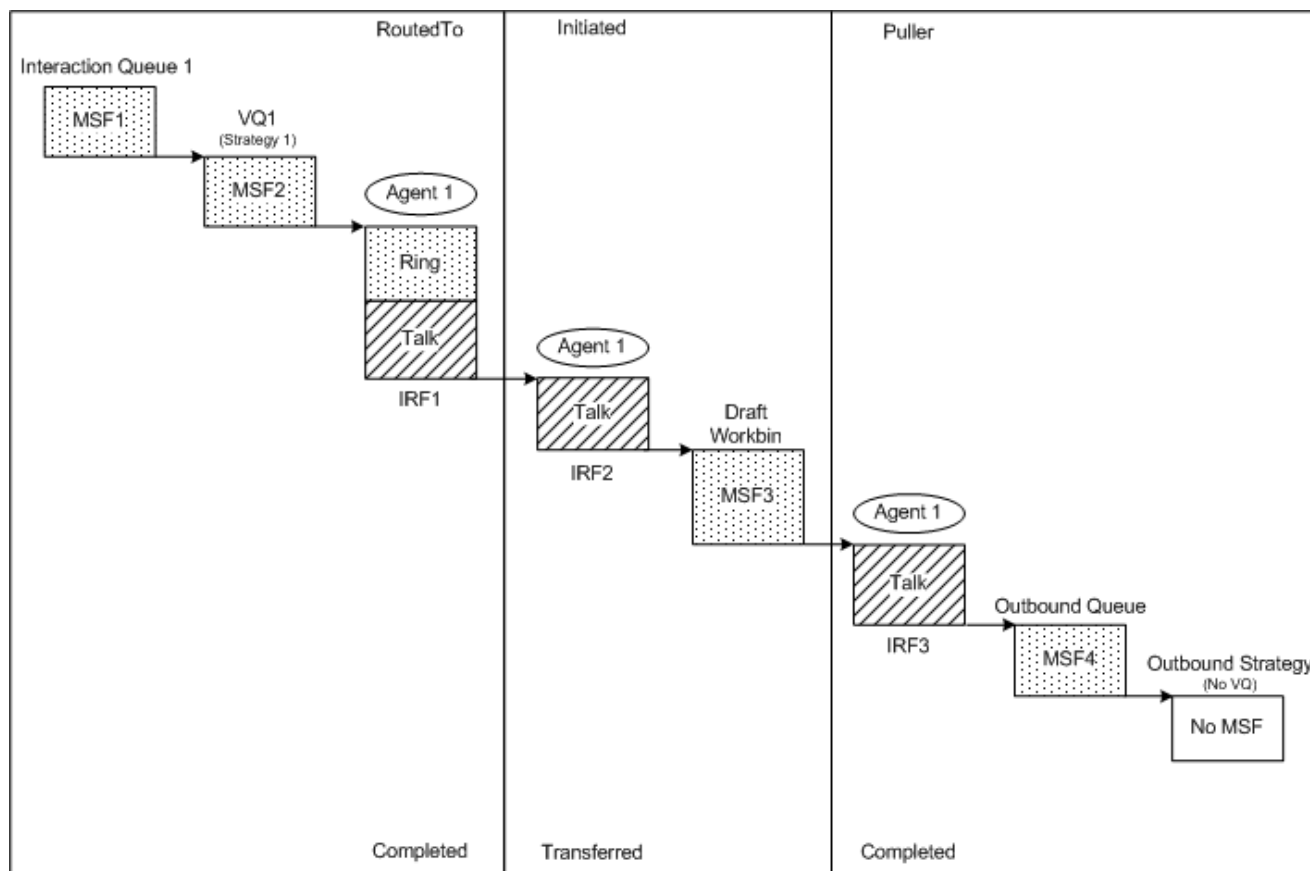

Agent pulls e-mail from an Interaction Queue or Workbin

The diagram shows the outcome when an e-mail interaction is pulled from an Interaction Queue or Workbin (MSF1) for further handling by Agent 1. After working on the e-mail, Agent 1 places the interaction into another Interaction Queue or Workbin (MSF2), for further processing.

Technical Descriptors illustrated:

- Puller/Transferred

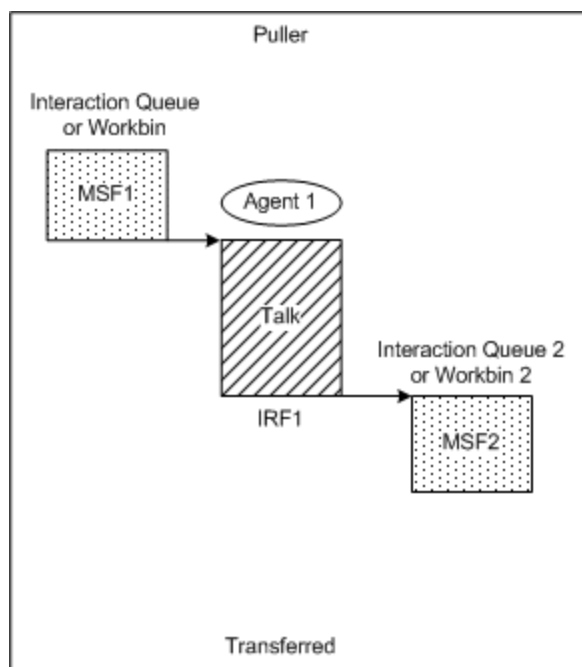

Agent saves draft reply before sending (hold)

The diagram shows the outcome of an e-mail interaction that is routed to an agent who replies to the e-mail, after first saving an initial version of the reply in a workbin, where the time in the workbin is considered to be hold, instead of mediation.

For information about when workbin time is considered to be hold, read the description of the `populate-workbin-as-hold` option.

For the outcome of the same interaction flow when the workbin time is considered to be mediation, see [Agent saves draft reply before sending \(mediation\)](#).

Technical Descriptors illustrated:

- RoutedTo/Completed
- Initiated/Completed

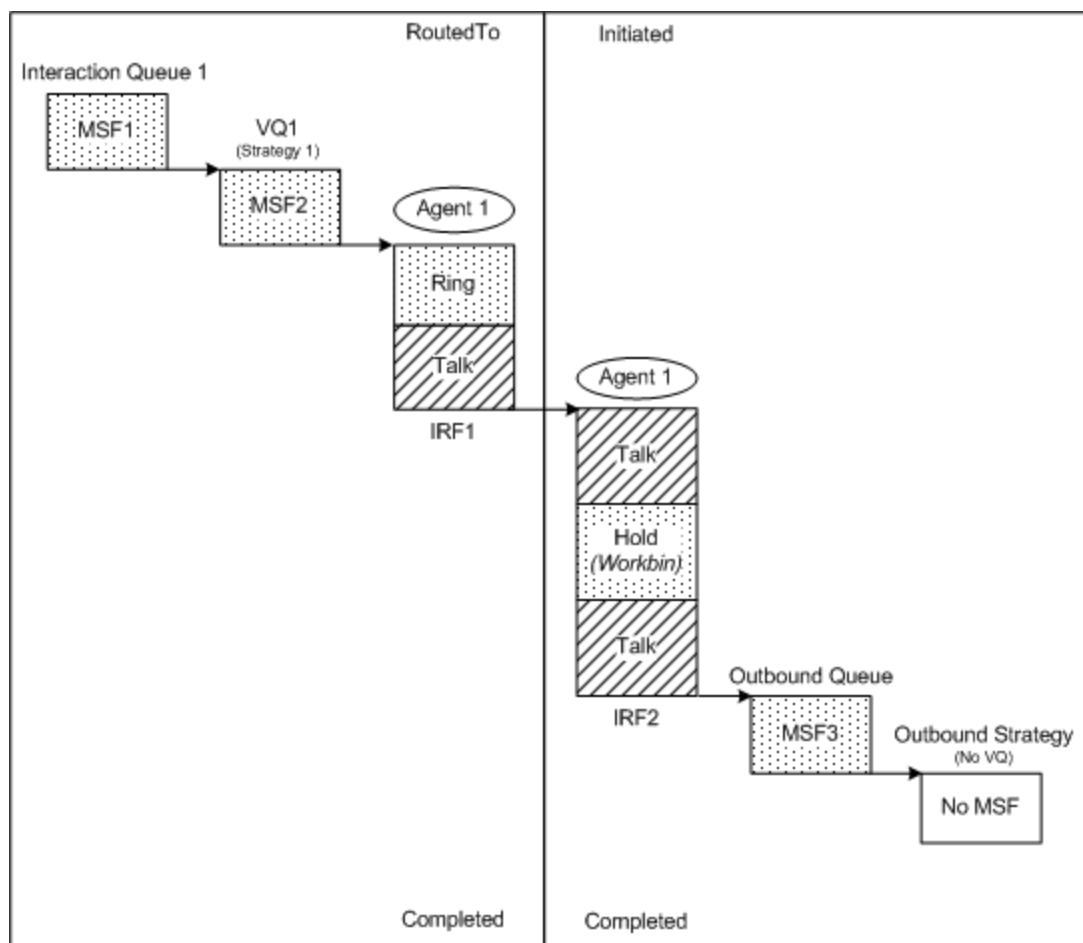

Agent sends outbound e-mail

The diagram shows the outcome of an e-mail interaction that the agent initiates. In other words, the e-mail is not a response to an e-mail that has been routed to the agent or transferred to the agent.

This scenario applies when an agent sends an unsolicited outbound interaction to a customer or, starting with release 8.5.003, the agent is sending an outbound reply to a customer where the interaction being replied to has already been terminated in Genesys Info Mart.

Technical Descriptors illustrated:

- Initiated/Completed

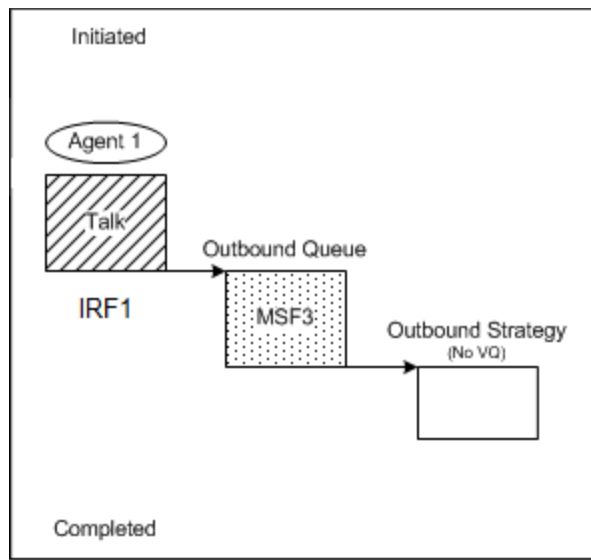

Multipart reply

The diagram shows the outcome of a multipart reply.

In this example, Agent 1 initiates two outbound replies. For example, Agent 1 may have received a new customer order (IRF1) and initiated one reply, which is to be completed by Agent 2 in Shipping (IRF2). At the same time, Agent 1 also initiated a reply to the customer, confirming the order and providing billing-related information. Agent 1 transfers the first outbound reply directly to Agent 2 (IRF3). Agent 1 remains in this outbound reply until Agent 2 accepts the invitation into the interaction. Agent 2 later completes this reply, placing it in an Outbound Queue, from which Outbound Strategy sends it out of the contact center. Agent 1 also creates and completes the second outbound reply (IRF4), now stopping the original inbound interaction, and places this second reply in an Outbound Queue, from which Outbound Strategy sends it out of the contact center. In this example, the second reply that Agent 1 created was actually the first reply sent to the customer.

Technical Descriptors illustrated:

- RoutedTo/Completed
- Initiated/Transferred
- ReceivedTransfer/Completed
- Initiated/Completed

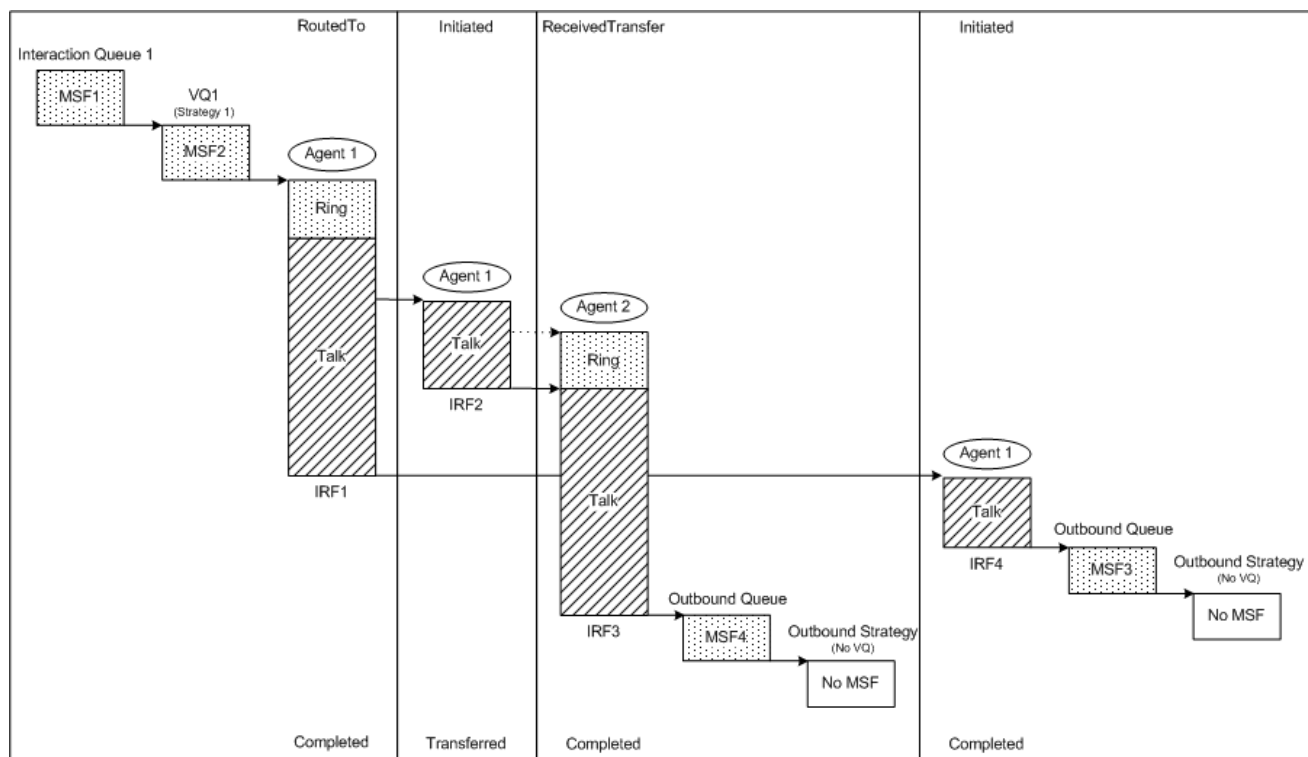

Multipart e-mail reply with unsent reply

The diagram shows the outcome of a multipart reply in which one of the replies was stopped without being sent.

This example illustrates the `OutboundStopped` technical result. The `OutboundStopped` technical result applies to any outbound multimedia interaction that is stopped without being sent; it is not limited to outbound replies. In this example, the outbound reply initiated by Agent 1 (IRF2), and transferred to Agent 2, is stopped by Agent 2 (IRF3). Agent 2 worked on the outbound reply for some time, but then stopped the reply without sending it. In the meantime, as in [Multipart reply](#), Agent 1 worked on a second reply, which was sent to the customer (IRF4).

Technical Descriptors illustrated:

- RoutedTo/Completed
- Initiated/Transferred
- ReceivedTransfer/OutboundStopped
- Initiated/Completed

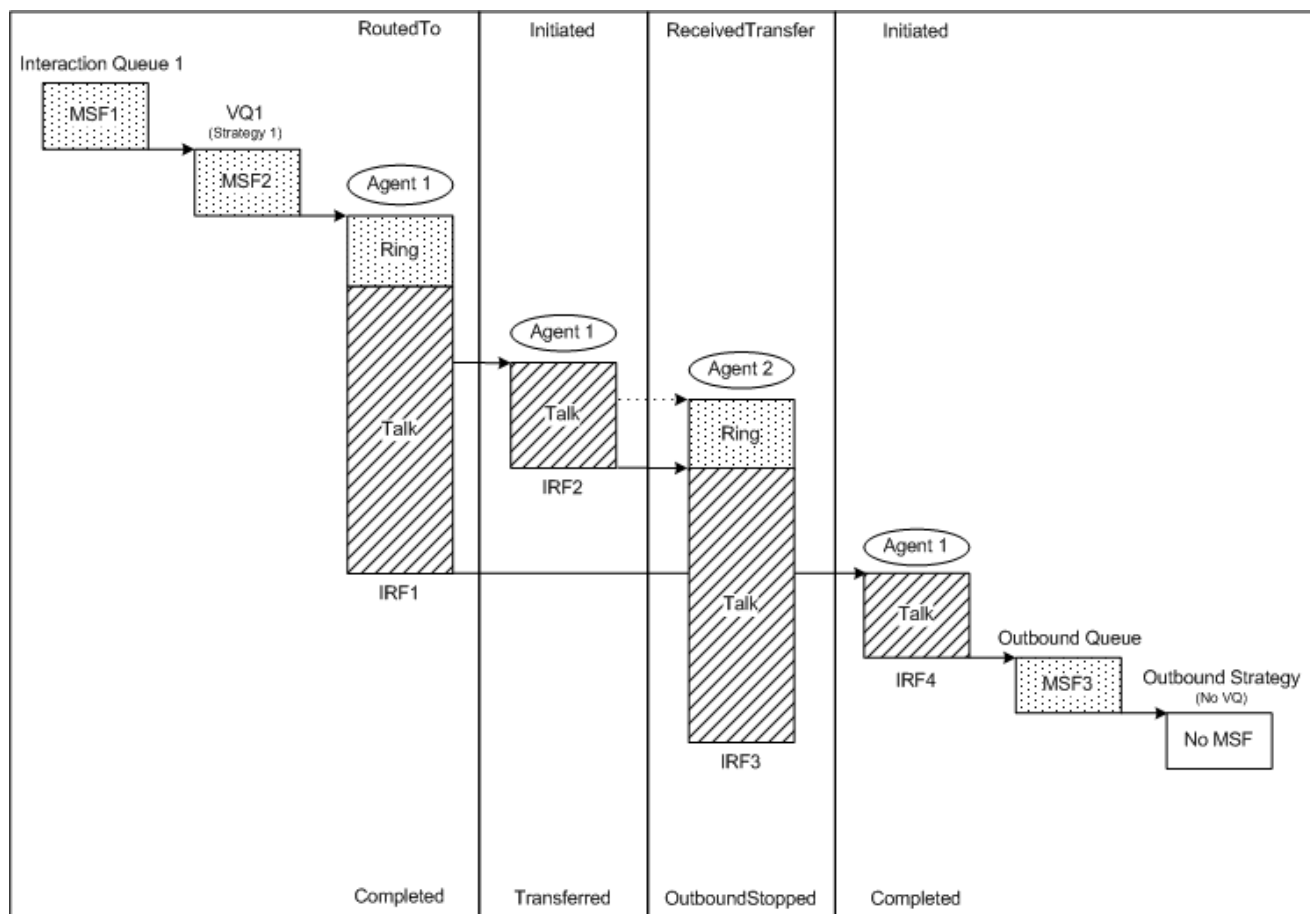

Routing strategy repeatedly fails to find a target

The diagram shows the outcome of an inbound e-mail interaction that is eventually routed to an agent after the routing strategy repeatedly failed to find an available agent.

In this example, Strategy 1 puts the interaction back into Interaction Queue 1 several times, until the strategy finally routes the interaction successfully to Agent 1 (IRF1). All the unsuccessful attempts to select an agent are combined into one mediation (MSF1 for Interaction Queue 1), except for the last attempt, which is when the interaction was successfully routed (MSF2 for VQ1). Given the focus of this example, the diagram does not show the continued processing after Agent 1 gets control of the interaction; the technical result for IRF1 depends on what Agent 1 does with the interaction.

Technical Descriptors illustrated:

- RoutedTo/depends on subsequent activity

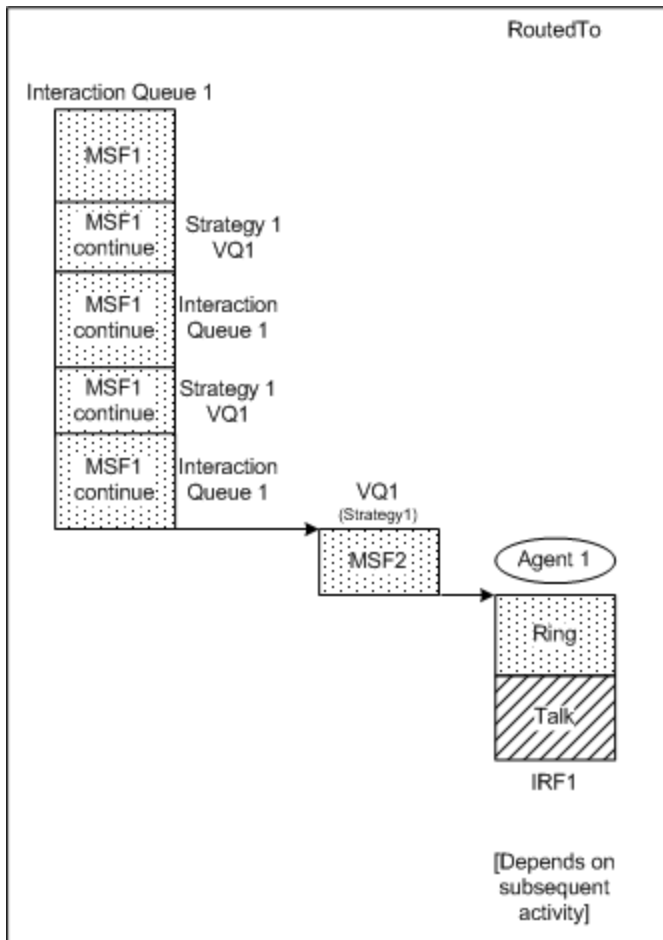

Chat Interactions

This page illustrates chat interaction flows that are available in multimedia deployments.

The chat interaction flows on this page describe the recognized, validated multimedia interactions that have been tested and that are supported by Genesys Info Mart for Genesys eServices chat. However, Genesys Info Mart supports full processing of any 3rd Party Media interactions, in addition to e-mail and chat interactions.

Use the chat interaction flows as a guide to interactions that do involve an online session with a customer (online interactions).

The interaction flows described in this guide are intended as examples that you can modify for your environment. However, Genesys does not guarantee results for modified interaction flows.

See [Multimedia diagram conventions](#) and [Diagram Conventions](#) for important information about interpreting the diagrams.

The following call flows are supported:

- [Strategy delivers chat to agent, and agent replies](#)
- [Agent invited into chat and invitation revoked](#)
- [Agent transfers chat to another agent](#)
- [Agent's attempt to transfer chat to another agent fails](#)
- [Agent conferences in another agent](#)
- [Agent's attempt to conference in another agent fails](#)
- [Chat consultation](#)
- [Chat conference through a queue](#)
- [Customer abandons chat in queue](#)
- [Customer abandons chat during routing](#)
- [Customer abandons chat during agent alerting](#)

Strategy delivers chat to agent, and agent replies

The diagram shows the outcome of a chat interaction that a routing strategy routes to an agent, who accepts the invitation and chats with the customer.

Technical Descriptors illustrated:

- RoutedTo/Completed

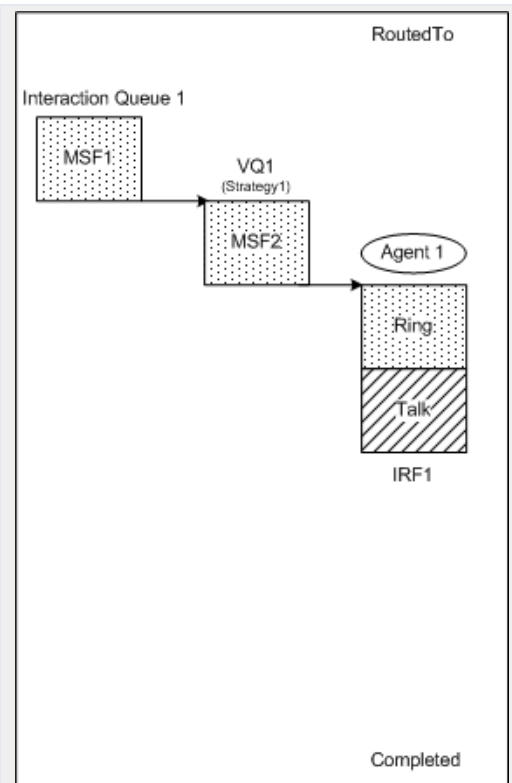

Agent invited into chat and invitation revoked

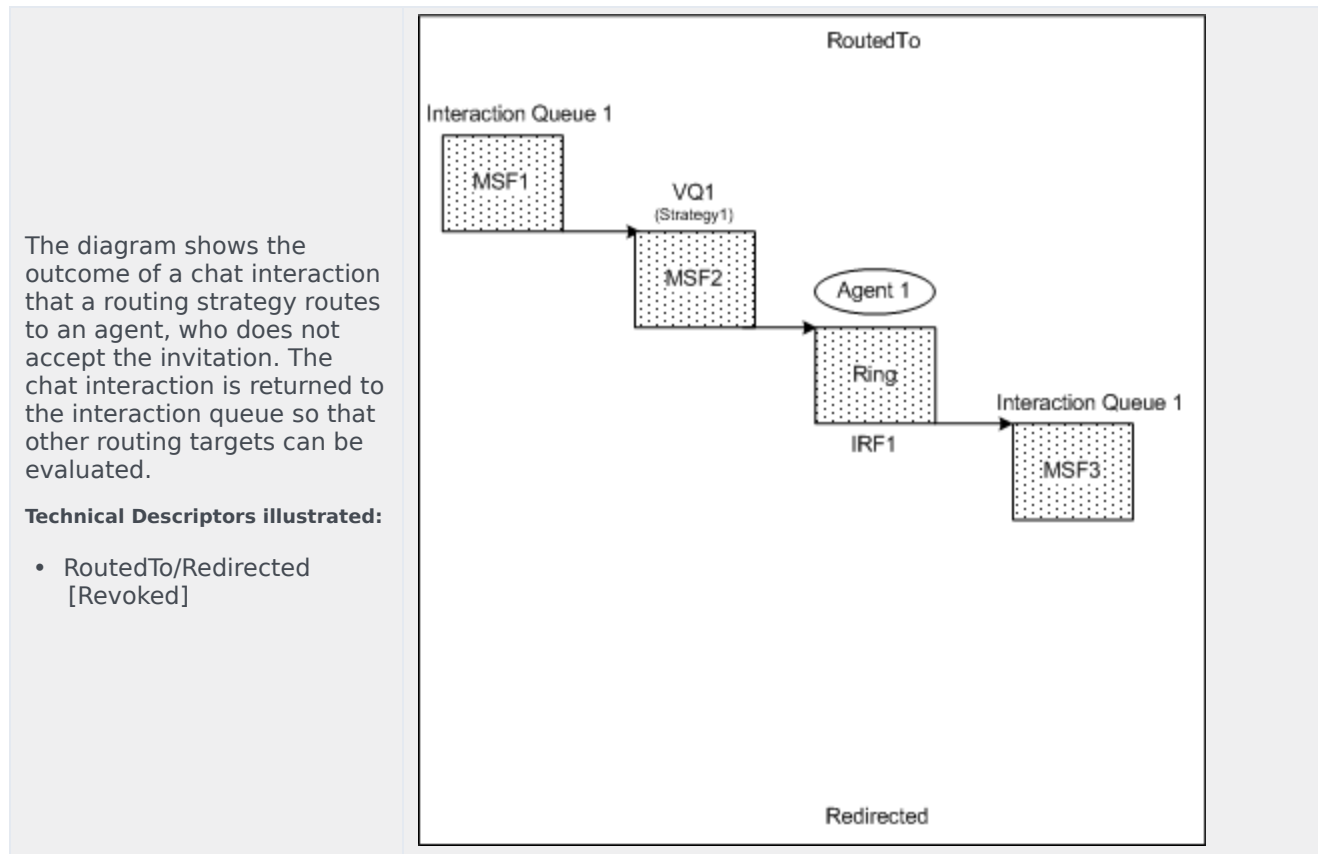

Agent transfers chat to another agent

The diagram shows the outcome of a chat interaction that is routed to an agent, who transfers the chat to another agent.

The interaction is routed to Agent 1. Agent 1 accepts the invitation into the interaction and chats with the customer (IRF1). Agent 1 then transfers the chat interaction to Agent 2, who accepts the invitation and then chats with the customer (IRF2).

Technical Descriptors illustrated:

- RoutedTo/Transferred
- ReceivedTransfer/Completed

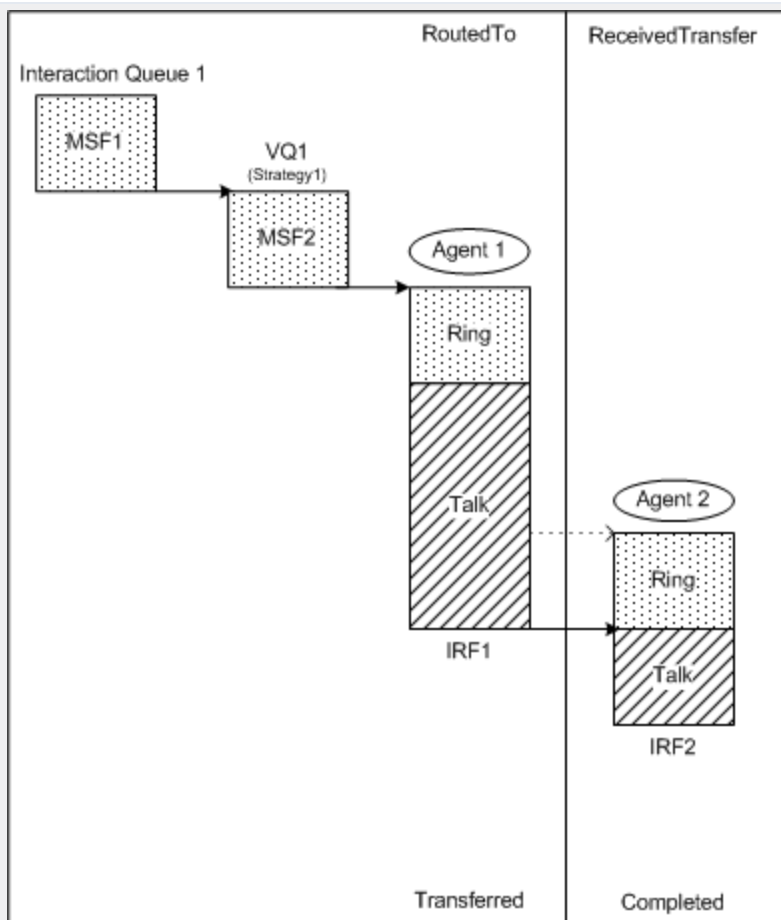

Agent's attempt to transfer chat to another agent fails

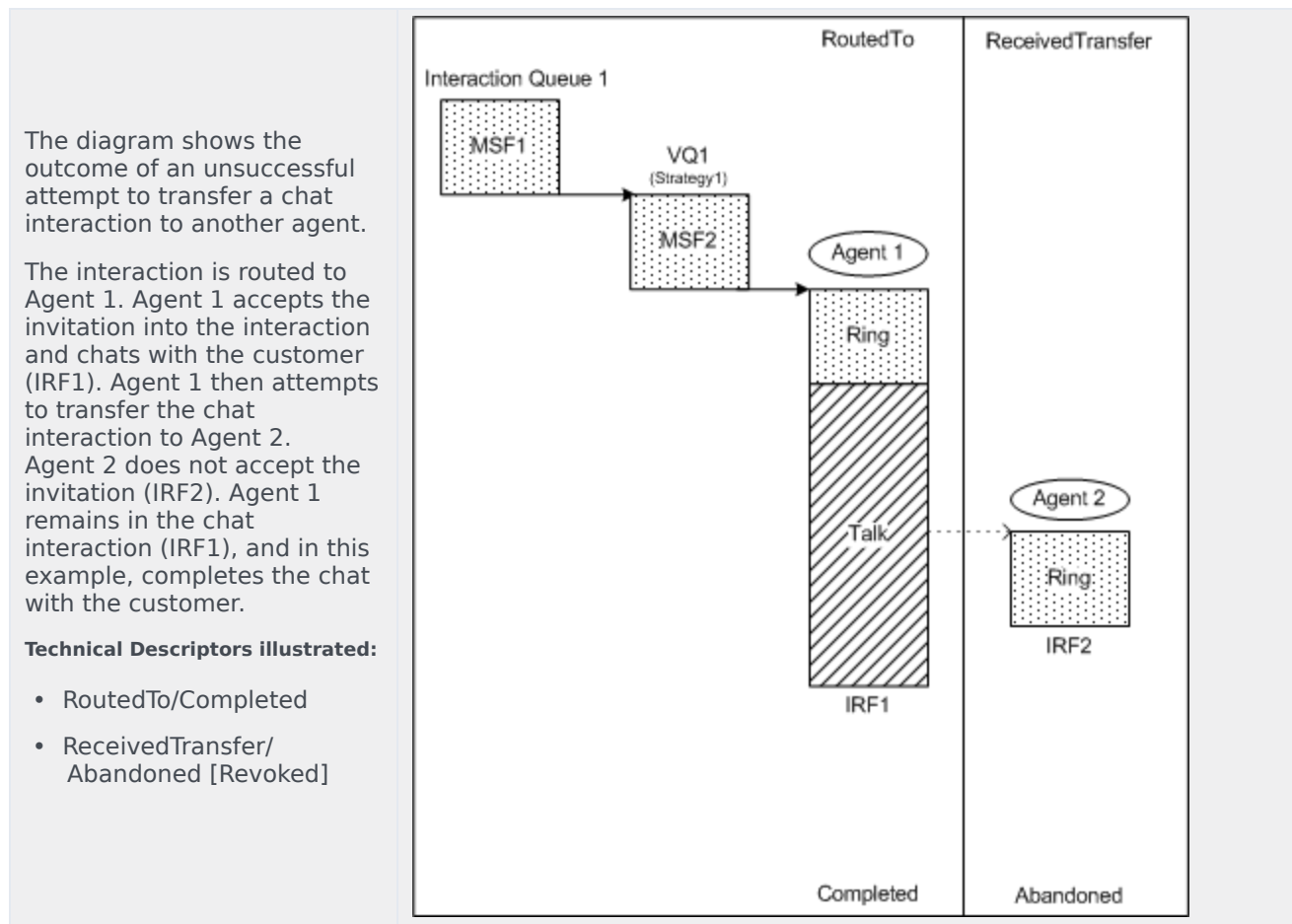

Agent conferences in another agent

The diagram shows the outcome of a chat interaction that is routed to an agent, who conferences in another agent.

The interaction is routed to Agent 1. Agent 1 accepts the invitation into the interaction and chats with the customer (IRF1). Agent 1 then attempts to conference in Agent 2. Agent 2 accepts the invitation and then also chats with the customer (IRF2).

Technical Descriptors illustrated:

- RoutedTo/Completed
- InConference/Completed

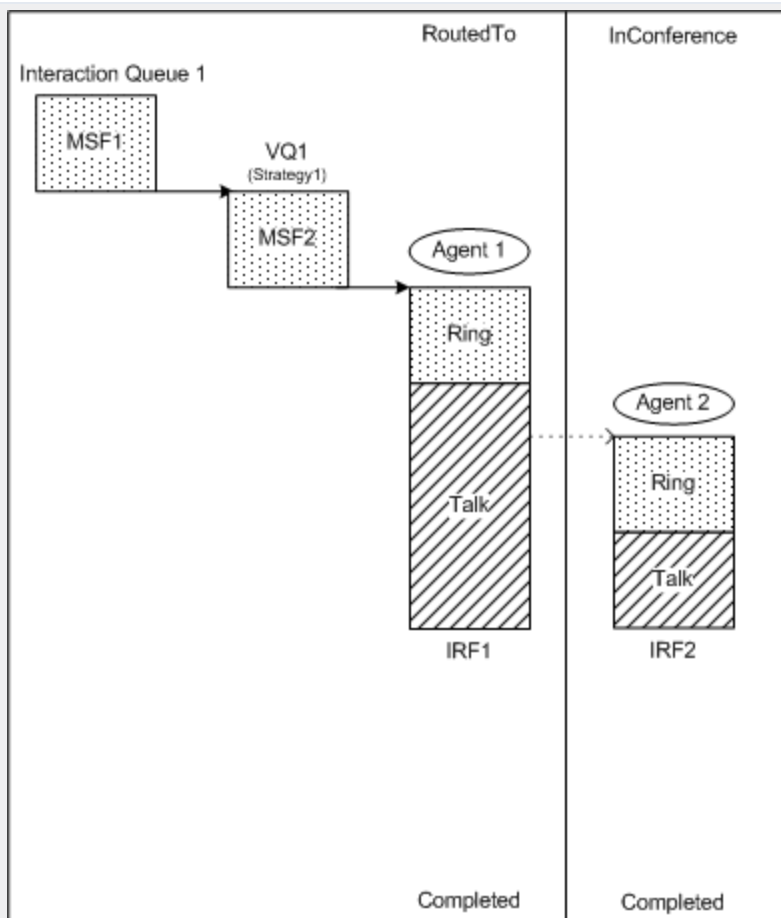

Agent's attempt to conference in another agent fails

The diagram shows the outcome of an unsuccessful attempt to conference another agent into a chat interaction. The interaction is routed to Agent 1. Agent 1 accepts the invitation into the interaction and chats with the customer (IRF1). Agent 1 then attempts to conference in Agent 2. Agent 2 does not accept the invitation (IRF2). Agent 1 remains in the chat interaction (IRF1), and in this example, completes the chat with the customer.

For a failed chat consultation attempt, the resource role for the receiving agent (Agent 2) will be either InConference or else ReceivedConsult, depending on when the attempt failed — specifically, depending on whether the scenario had advanced far enough for the visibility mode to be known.

Technical Descriptors illustrated:

- RoutedTo/Completed
- InConference/Abandoned [Revoked]

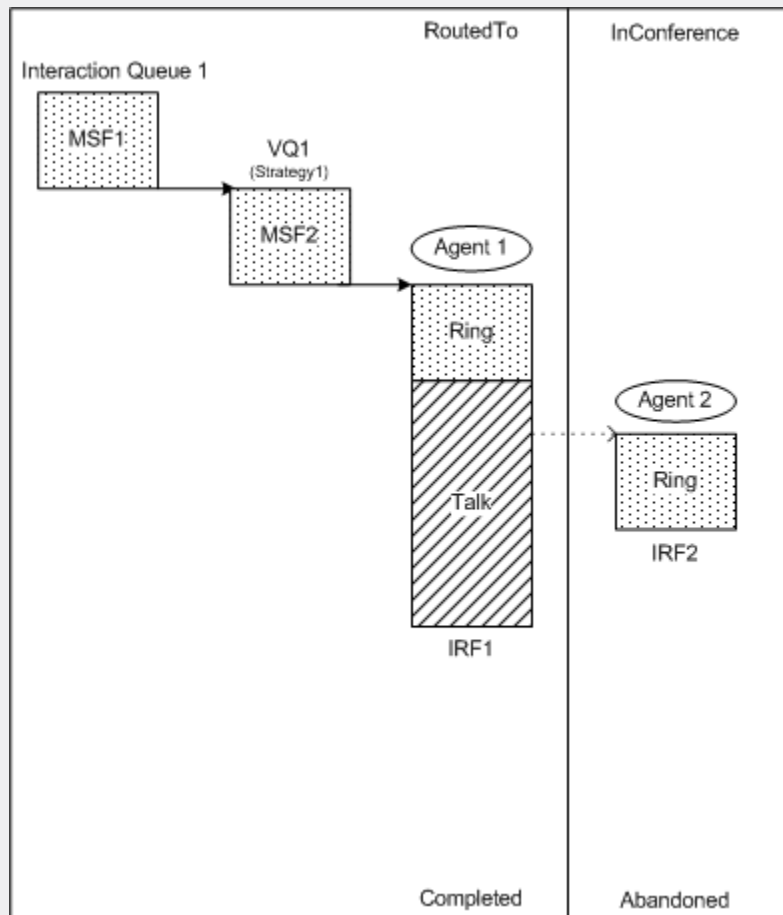

Chat consultation

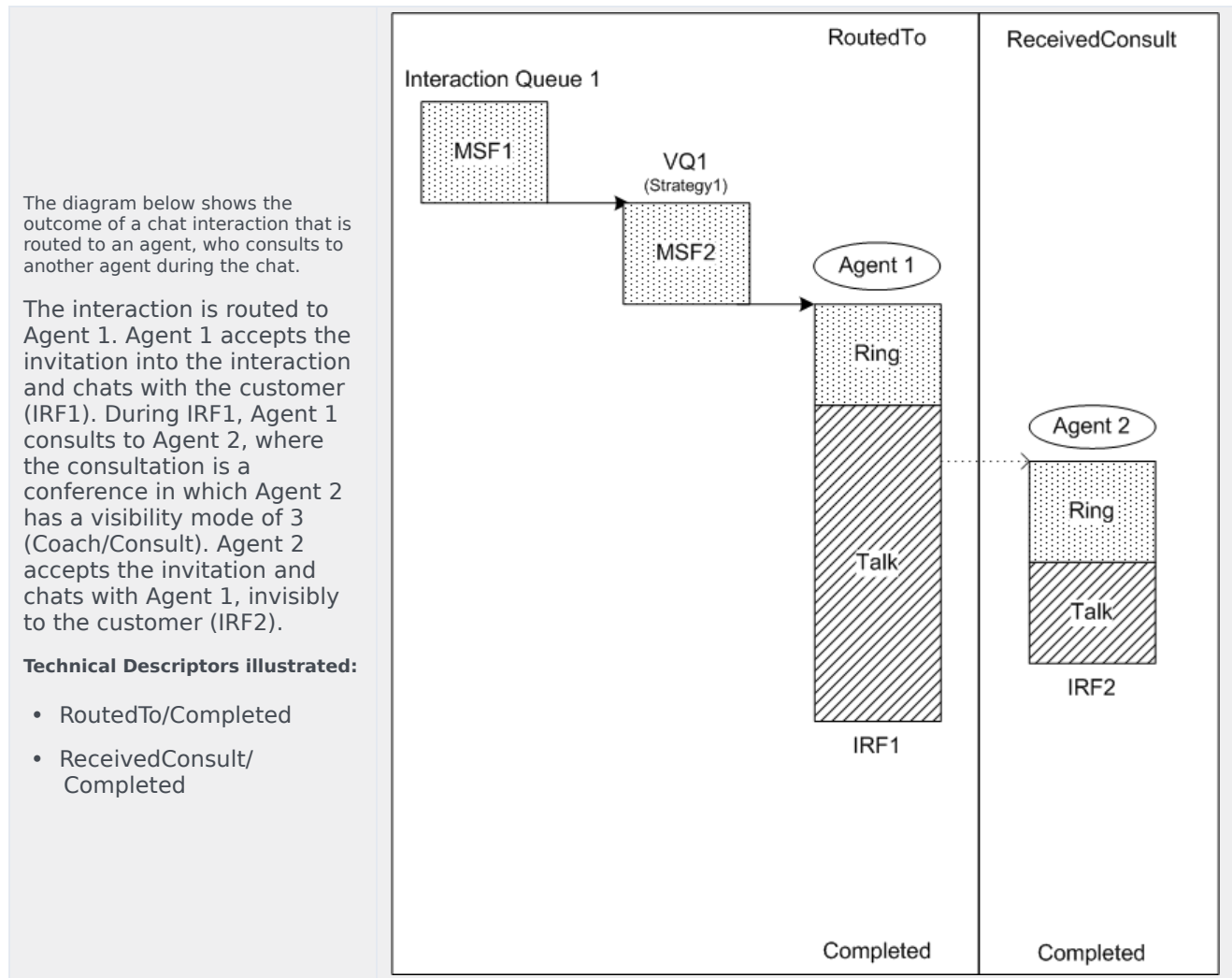

Chat conference through a queue

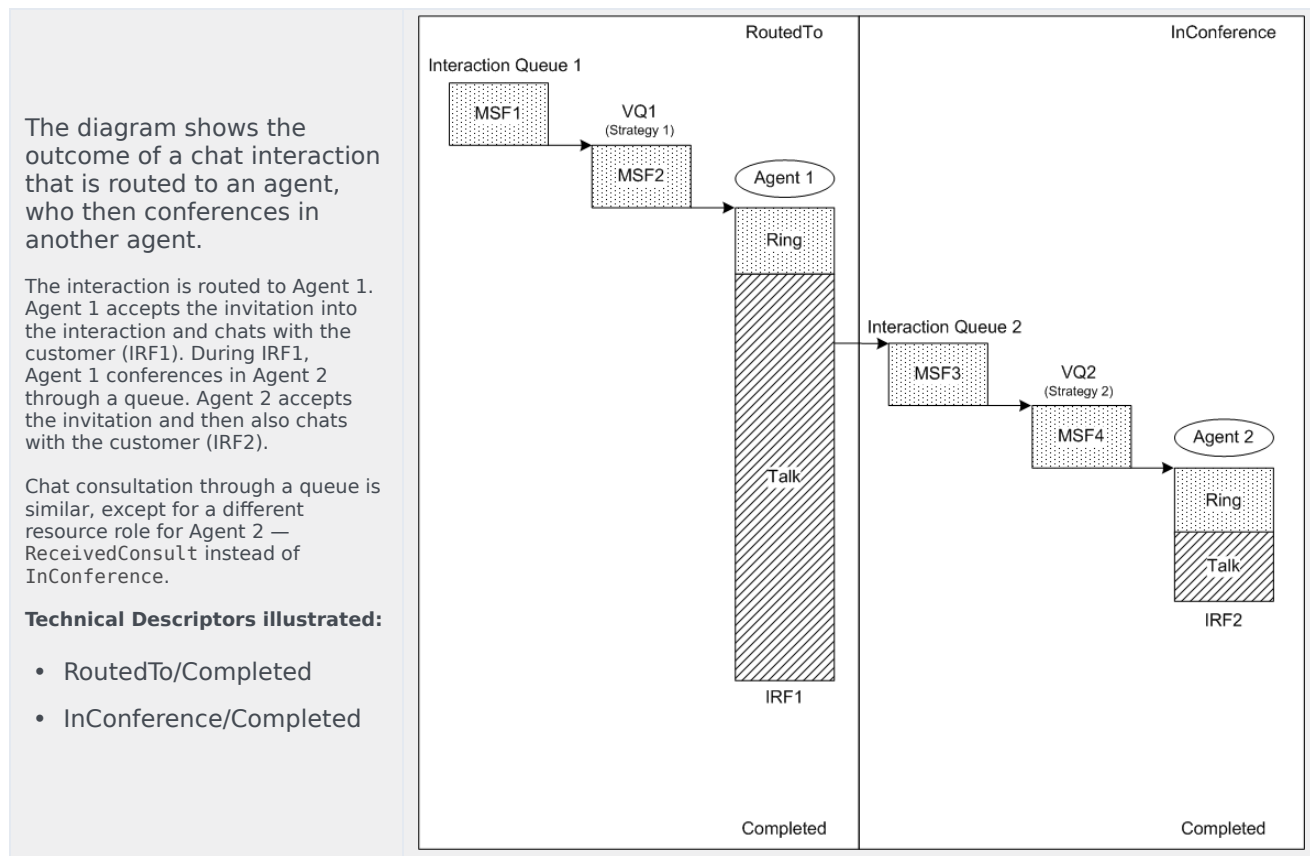

Customer abandons chat in queue

The diagram shows the outcome of a chat interaction that is submitted to an inbound interaction queue, but is abandoned by the customer while it is in the interaction queue.

Technical Descriptors illustrated:

- Received/CustomerAbandoned [AbandonedWhileQueued]

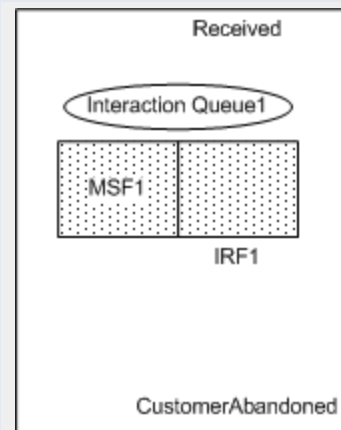

Customer abandons chat during routing

The diagram shows the outcome of a chat interaction that is submitted to an inbound interaction queue, but is abandoned by the customer while a routing strategy is attempting to route the interaction.

The resource role of Puller is used because the strategy pulled the interaction from the interaction queue.

Technical Descriptors illustrated:

- Puller/CustomerAbandoned

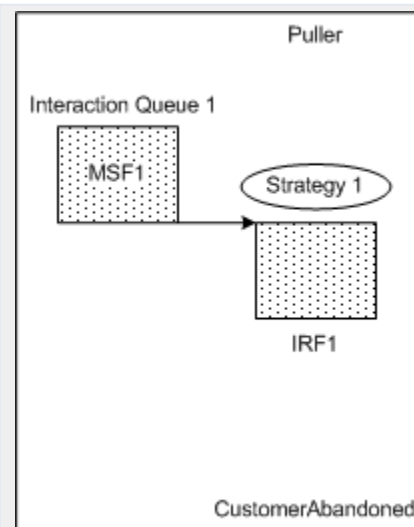

Customer abandons chat during agent alerting

The diagram shows the outcome of a chat interaction that is abandoned while the agent is being alerted.

The interaction is routed to Agent 1. The customer abandons the chat interaction before the agent accepts the invitation.

Technical Descriptors illustrated:

- RoutedTo/CustomerAbandoned [AbandonedWhileRinging]

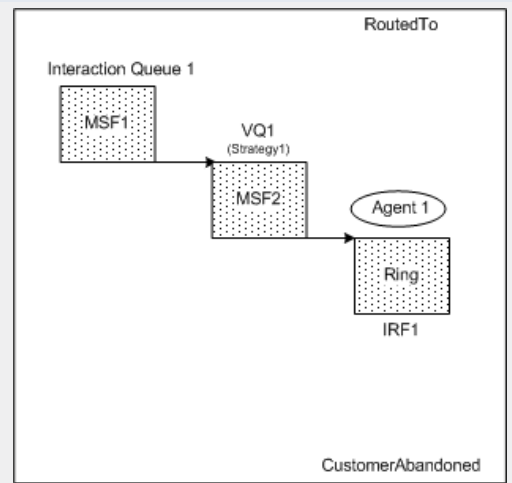

Data Lineage: Voice of Data

This page describes how Genesys Info Mart tracks data, enabling you to understand what data is collected and how it is processed. This information can be used for reporting and to assess data accuracy (data validation).

About data lineage in Genesys Info Mart

Data lineage provides information that records the history of job execution and data transformation for each piece of data. Data stored as part of data lineage allows for bi-directional data tracking and enables you to answer the following questions:

- What process created the piece of data?
- What was the source of the data?
- What data was created by a specified job?
- What data in the system was created based on specified source data?

There are two aspects of data lineage:

- Voice of Data — This feature pertains to data-quality validation and troubleshooting. It enables you to trace a particular data item in a source system based on data in the target system (in other words, from data to source), and also to trace data in the opposite direction (from source to target).
- Voice of Process — This feature provides data-processing history, tracing which ETL process created or updated this piece of data (in other words, from data to process). It also traces in the opposite direction (from process to data).

Important

The information in this *User's Guide* focuses on Voice of Data. For information about Voice of Process, see [Job History and Status](#) in the *Genesys Info Mart Operations Guide*. For detailed descriptions of the tables and views related to data lineage, see the information about Info Mart Service and Staging Tables and Administrative Views in the *Genesys Info Mart Physical Data Model* for your RBDMS.

Voice of Data

Voice of Data functionality enables you to trace data origins or targets.

To use Voice of Data, you must be familiar with which GIDB tables provide which kind of data. This information, called *static mapping*, cannot be derived from the schema. The following table

summarizes the connections, which are discussed in more detail below.

Data Mapping

Genesys Info Mart		GIDB	
Table	Field	Table	Field
INTERACTION_FACT	MEDIA_SERVER_IXN_GUID	GIDB_G_CALL_V GIDB_G_CALL_MM	CALLID
INTERACTION_RESOURCE_FACT	INTERACTION_RESOURCE_ID ^a	GIDB_G_PARTY_V GIDB_G_PARTY_MM	PARTY_KEY
INTERACTION_RESOURCE_FACT	PARTYGUID	GIDB_G_PARTY_V GIDB_G_PARTY_MM	PARTYGUID
MEDIATION_SEGMENT_FACT	MEDIA_SERVER_IXN_GUID	GIDB_G_CALL_V GIDB_G_CALL_MM	CALLID
	MEDIATION_GUID	GIDB_G_PARTY_V GIDB_G_PARTY_MM GIDB_VIRTUAL_QUEUE_V GIDB_VIRTUAL_QUEUE_MM	PARTYGUID VQID
RESOURCE_	RESOURCE_CFG_DBID RESOURCE_CFG_TYPE_ID	GIDB_GC_AGENT GIDB_GC_ENDPOINT GIDB_GC_SCRIPT	ID (dbid)
GROUP_	GROUP_CFG_DBID	GIDB_GC_GROUP	ID
PLACE	PLACE_CFG_DBID	GIDB_GC_PLACE	ID
SKILL	SKILL_CFG_DBID	GIDB_GC_SKILL	ID

a. The PARTY_KEY of the last party in the INTERACTION_RESOURCE_FACT (IRF) record is used as the INTERACTION_RESOURCE_ID. Primary keys can match in a many-to-one relationship.

The information in the **Data Mapping table** is a starting point that enables you to:

- Trace a record back to the source records that triggered its creation, or trace data from its origin to its final target.
- Select an interaction in Genesys Info Mart and pull out from the Interaction Concentrator database (IDB) all corresponding records.
- Trace the information in IDB records back to the source application logs (for example, the T-Server, SIP Server, or Interaction Server logs).

How to use Voice of Data

The basic concept of Voice of Data is that each interaction can be traced from its initial entry into your environment through its conclusion by way of specific linking IDs, which enable you to trace, in either direction, the processing records from IDB to the Genesys Info Mart database via GIDB tables.

To accomplish this, you can trace each of the interaction records in the Info Mart fact tables back to source tables in GIDB using keys that indicate from which records in the source tables a particular record was created. Multiple links enable you to trace the interaction records in the fact tables to GIDB tables, from where you can find records in IDBs and ICON application logs.

For example, the IRF table stores the PARTYGUID of the handling party. A simple join between GIDB_G_PARTY with either G_PARTY or PARTYGUID links the IRF table with the corresponding party record in GIDB/IDB.

Use cases

The following examples show some specific ways to use Voice of Data. The examples provide only a small sampling of the sorts of questions you can answer using Voice of Data:

- Identify the source of GIDB data
- Identify the source ICON instance

How do I know where specific GIDB data comes from?

To identify the source for GIDB data, join the GIDB table of interest with the CTL_DS table using DATA_SOURCE_KEY, CTL_DS. The value for DS_DBID in the resulting data set provides the value of the data source DBID (for example DBID of the T-Server for voice call data).

We use multiple instances of ICON. Which one created this specific record?

To identify the instance of ICON that was the source of a particular record in GIDB, use the GSYS_SYS_ID field in the GIDB record. This field contains the DBID of the ICON application as defined in the Configuration Layer.

Representing Dates and Times of Day

Because of the large volume of data handled by Genesys Info Mart, most SQL queries of a fact table are constrained by date and time. This page describes how Genesys Info Mart represents dates and times of day.

About dates and times of day

Dates and times of day are stored in the `START_TS` and `END_TS` fields, which mark the start and end of each handling stage. The `START_DATE_TIME_KEY` and `END_DATE_TIME_KEY` reference the `DATE_TIME` dimension, which exists in all fact tables. Dates and times are stored in Coordinated Universal Time (UTC) format. You can express local, enterprise, or tenant time using custom `DATE_TIME` dimensions that offset the UTC time by a specified amount of time.

Because 0 equals 1970 January 1 in UTC, each custom `DATE_TIME` dimension table will associate this UTC key with a different local time that is relevant for your enterprise. This enables you to use the same keys to create reports in different time zones.

Tip

For instructions on configuring custom `DATE_TIME` tables, see [Creating Custom Calendars](#) in the *Genesys Info Mart Deployment Guide*.

How dates and times can be constrained

Each fact table row has a surrogate key, `START_DATE_TIME_KEY`, which references the `DATE_TIME` dimension that represents its start date and time. This surrogate key can constrain the fact table rows by start date and time of day. Similarly, the `END_DATE_TIME_KEY` can be used to constrain the fact table rows by end date and time of day.

Each fact table row contains measurements that represent the start date and time of day, and the end date and time of day. These measurements can constrain fact table rows by any arbitrary time span, based on whether the fact table row:

- Starts and ends within the time span.
- Starts before, and ends within, the time span.
- Starts within, and ends after, the time span.
- Starts before, and ends after, the time span.

In any case, you must create the appropriate database indexes in order to efficiently retrieve the data you want.

All fact tables have surrogate key references to the DATE_TIME dimension that represent the 15-minute date and time interval in which a fact started and ended.

The DATE_TIME dimension is useful for constraining based on an arbitrary range of 15-minute time intervals, because this single dimension includes both date and time of day. The dimension keys increase regularly each 15 minutes.

Example: Working with timestamps and the DATE_TIME dimension

The following example illustrates how Genesys Info Mart represents the date and time of an inbound call in local time.

An inbound call arrives at a contact center in San Francisco on October 21, 2009 at 5:05 PM local time (PDT). This time corresponds to 1:05 AM on October 22, 2009 in the UTC GMT time zone, or 1256173500 seconds, expressed in UTC integer format. This integer is stored in the START_TS field in the table containing data about the call.

The start time of the call falls into a 15-minute time interval that begins on October 22, 2009 at 1:00 AM in the UTC GMT time zone, or 1256173200 seconds in UTC integer format. This integer is stored in the START_DATE_TIME_KEY field in the tables containing data related to the call. The value is a surrogate key that can be used to link to the corresponding DATE_TIME_KEY field in any DATE_TIME_CUSTOM dimension. These custom tables contain text labels for the day of the week, month, year, and so on, in whichever local time zone formats your business requires.

In this example, a DATE_TIME_CUSTOM table has been created for the Pacific time zone containing labels in local PDT format. The START_DATE_TIME_KEY field in the fact table containing the UTC integer 1256173200 (corresponding to 5:00 pm PDT), can be used to link to this DATE_TIME_CUSTOM dimension. The correct text labels for the Pacific time zone can then be retrieved for your reports.

Calculating timestamps

To show timestamps in reports converted to a particular time zone, use a simple calculation combining the START_TS (or END_TS) field of a fact table with the DATE_TIME_KEY and CAL_DATE fields of the DATE_TIME_CUSTOM table created for that time zone.

For example, to convert the timestamp value, 1256173500, from the example above, where the time of call arrival is stored in UTC seconds format in the START_TS field of the corresponding INTERACTION_RESOURCE_FACT (IRF) row in a Microsoft SQL Server RDBMS, execute the following query on the DATE_TIME_CUSTOM dimension and IRF table:

```
select DTC.CAL_DATE + CAST ((IRF.START_TS - DTC.DATE_TIME_KEY) as float) / CAST (86400 as float)
from DATE_TIME_CUSTOM DTC, INTERACTION_RESOURCE_FACT IRF
where DTC.DATE_TIME_KEY = IRF.START_DATE_TIME_KEY
```

The resulting value is October 21, 2009 at 5:05 pm in PDT time zone.

To make the same conversion in an Oracle RDBMS, execute the following query:

```
select DTC.CAL_DATE + (IRF.START_TS - DTC.DATE_TIME_KEY) / 86400
from DATE_TIME_CUSTOM DTC, INTERACTION_RESOURCE_FACT IRF
where DTC.DATE_TIME_KEY = IRF.START_DATE_TIME_KEY
```

Calendar years and week-numbering years

There are two available ways to number the weeks in a year:

- Full-week numbering — In this system, weeks always contain seven days and always start on the day of the week specified as Day 1 in the first-day-of-week configuration option. This system supports the ISO-8601 week configuration used in the European Union and Russia.
- Simple-week numbering — In this system, the weeks calendar matches the calendar year. Week 1 begins on January 1. As a result, the first day of the week differs each year. Most of the time, Weeks 1 or 52 will have fewer than seven days. This is the functionality used in previous releases of Genesys Info Mart.

Table fields for full-week numbering

The DATE_TIME table contains several fields that are used to support the full-week numbering system.

- WEEK_YEAR — This field stores a Week Numbering year. This year may be different from Calendar year. For example, in ISO-8601, 31 December of 2007 is Week 1 Day 1 of 2008. So in this case we have 2007 as the Calendar year and 2008 as the Week Numbering year.
- LABEL_YYYY_WE_D — The label for the day of the week.
- LABEL_TZ — This field stores the time zone offset.

Configuration options for week-numbering

A number of configuration options control how week-numbering is done. For more information, see the descriptions of the [\[date-time\]](#) options in the *Genesys Info Mart Configuration Options Reference*.

Important

In deployments that include Reporting and Analytics Aggregates (RAA) or custom aggregation that uses the DATE_TIME table, Genesys strongly recommends that you do not change [\[date-time\]](#) options that set basic features of the calendar — such as the time zone — after the aggregation engine has started to aggregate data. If you do, at the very least, you will likely need to re-aggregate data.

Maintaining the calendar dimensions

The DATE_TIME dimension is a default calendar that is set up when Genesys Info Mart is initialized and that needs to be populated ahead of time on a continuing basis. Maintenance of the DATE_TIME dimension is controlled by the date-time-min-days-ahead and date-time-max-days-ahead configuration options in the **[date-time]** configuration section. Similarly, maintenance of any custom calendar dimension(s) is controlled by equivalent options in the applicable **[date-time-*]** configuration section(s).

Job_MaintainGIM adds records to the calendar table if the last existing record is earlier than $\langle\text{current-date}\rangle + \text{date-time-min-days-ahead}$. Records are added until $\langle\text{current-date}\rangle + \text{date-time-max-days-ahead}$.

Example

For example, take a scenario in which **date-time-min-days-ahead** is set to 183, **date-time-max-days-ahead** is set to 366, and today is March 30, 2011. In other words, $\langle\text{current-date}\rangle + \text{date-time-min-days-ahead} = \text{September 29, 2011}$.

- **Case 1:** DATE_TIME is populated until January 1, 2012.
Since $(\text{March 30, 2011} + 183) < \text{January 1, 2012}$, **Job_MaintainGIM** will not add any records to the calendar table.
- **Case 2:** DATE_TIME is populated until June 1, 2011.
Since $(\text{March 30, 2011} + 183) > \text{June 1, 2011}$, **Job_MaintainGIM** will add records to the calendar table until $(\text{March 30, 2011} + 366) = \text{March 30, 2012}$.

Data-Quality Considerations

This page discusses the implications for data quality of certain challenging aspects of extract, transform, and load (ETL) processing:

- [Partially merged calls](#)
- [Error handling in case of missing data](#)
- [High availability](#)

Partially Merged Calls

In multi-site scenarios, Genesys Info Mart must merge data from the multiple sites. If an interaction moves from site to site during the handling process, Genesys Info Mart uses linkage data to integrate the data from various T-Servers into a single interaction. This merging can be disrupted for a number of reasons, causing data-quality issues.

There are three major cases when data from a site might be unavailable:

- The site is not monitored.
- The site is monitored, but information is missing.
- Information is delayed.

Data issues in a partially monitored environment

If you configure Genesys Info Mart to extract voice interaction data from topologies in which not all T-Servers or IVR Servers involved in the call flow are monitored by ICON, data inconsistencies can occur, such as incomplete and missing data.

Important

If you have an environment that includes intentionally unmonitored sites, note these sites in the `GSYS_DNPREMOTELOCATION` table, as described in [Configuring Info Mart database for merge](#) in the *Genesys Info Mart Deployment Guide*.

A partially monitored environment can result in missing data at the start, middle, or end of an interaction. The following interaction scenarios, or any combination of them, can affect the population of interaction data within Genesys Info Mart, resulting in data inconsistencies:

- The interaction originates in an unmonitored T-Server.

- The interaction terminates in an unmonitored T-Server.
- The interaction originates in a monitored T-Server, moves to an unmonitored T-Server, and then passes on to a monitored T-Server.

Important

Each time that the interaction moves from an unmonitored to a monitored T-Server, it appears to be a new interaction. For example, a single interaction might start on a monitored T-Server, be sent to an unmonitored T-Server, and then be sent to a monitored T-Server. This single interaction is represented in Genesys Info Mart as two interactions. When this type of interaction scenario occurs, the linkage information that ties an interaction together as it moves from T-Server to T-Server is incomplete, and ICON cannot associate what it sees as multiple calls into a single interaction.

A partially monitored deployment can result in data that is incorrect or missing from the following fact tables:

- **INTERACTION_FACT (IF)** — Some interaction facts will be missing where entire calls or parties are missing in the source data.
- **INTERACTION_RESOURCE_FACT (IRF)** — Some IRFs might not reflect accurate information about mediation resources; consultation, conference, and transfer metrics; technical descriptors; routing targets; and service level flags, such as **MET_SERVICE_OBJECTIVE_FLAG** and **SHORT_ABANDONED_FLAG**. This occurs because these fields are highly dependent on other resources that are involved in the interaction which might or might not be monitored. Because these fields are highly dependent on other resources that are involved in the interaction, incorrect data results when the other resources are not monitored.
- **IXN_RESOURCE_STATE_FACT (IRSF)** — In some IRSFs, the **STATE_DESCRIPTOR** and **STATE_ROLE** values of the referenced Interaction Resource State might not be accurate for the states that are generated for IRFs. Because these values are populated based on interaction-type information from T-Server, incorrect data results when this information changes as a result of an unmonitored T-Server in the environment.
- **MEDIATION_SEGMENT_FACT (MSF)** — Some MSFs might be missing or have incorrect technical descriptor values because the ETL cannot determine why the interaction was placed in the queue or virtual queue, or whether it was answered or abandoned after it was distributed from the queue or virtual queue.

Late Data

Late data from sources that Genesys Info Mart considers to be currently active can be a result of various issues, such as intermittent connectivity issues for an IDB. For example, you might currently have data for only the beginning of an interaction, but data from a second T-Server is anticipated to arrive “soon”. In this case, soon means that data should arrive before the timeout set in the Genesys Info Mart `extract-data-stuck-threshold` configuration option, which specifies the allowable delay to wait for the missing data to become available, or before the merge timeout that is controlled by the `max-call-duration` option. If the delayed data arrives before the stuck threshold timeout expires, the interaction is processed normally. If the threshold expires before the data arrives, the data is treated as missing.

For more information about the Genesys Info Mart timeouts, see the [Genesys Info Mart Configuration Options Reference](#). For the definition of what Genesys Info Mart considers to be active data sources, see [Genesys Info Mart Terminology Conventions](#) in the [Deployment Guide](#).

Error Handling in Case of Missing Data

For various reasons, information from a data source for a specific time range might be missing from a monitored site. In an HA environment, a single failure does not result in loss of data. If, in exceptional circumstances, multiple failures occur, the HA environment becomes, in effect, a non-HA environment.

For a full discussion of the potential points of failure in a non-HA environment and the implications for data quality, see the section on error handling in the chapter about ETL processing in the [Genesys Info Mart 8.1 Deployment Guide](#).

Configuration options for missing-data behavior

For transformation, two configuration options are important for controlling the handling of missing data:

- `error-policy-islink-dangling`
- `error-policy-irf-exception`

The first option enables you to determine whether missing data is handled as an exception. If it is, the second option enables you to specify how such an exception is handled.

For more information about Genesys Info Mart error-handling, see the section on error handling in the chapter about ETL processing in the [Genesys Info Mart 8.1 Deployment Guide](#) and the **`error-policy-*`** option descriptions in the [Genesys Info Mart Configuration Options Reference](#).

Missing Configuration Objects

Genesys Info Mart checks the list of known configuration objects during data transformation. If **`Job_TransformGIM`** notes a missing configuration object during transformation of configuration facts data, Genesys Info Mart records the information in the `STG_IDB_FK_VIOLATION` table.

During transformation of data types other than configuration data, Genesys Info Mart treats such missing configuration objects as late-arriving and creates placeholders for the missing objects based on the configuration object type and its unique ID. When the missing configuration objects arrive from Configuration Server, these placeholders are populated with missing data. The unique configuration ID prevents accidental duplication of configuration objects.

High availability

Deploying a high availability (HA) configuration can greatly reduce the possibility of data loss and

other issues with data quality. Genesys recommends using HA throughout the data chain, from data sources through Interaction Concentrator. Genesys Info Mart is designed to take advantage of HA configurations in order to determine and draw on the most complete and reliable data available.

In an HA configuration, each HA set of Interaction Concentrator instances consists of two or more redundant ICONs populating redundant IDBs. Genesys Info Mart selects available data in such a way that it takes the most complete and correct set of data from one of the redundant IDBs with no duplications. To accomplish this, Genesys Info Mart uses data-session information that ICON stores in each IDB to identify whether the data for the time period that is to be extracted is complete and correct. Genesys Info Mart extracts data from whichever one of the redundant IDBs has the most complete and reliable data for a particular time range.

This approach to identifying the best data for any period eliminates the need for resource-consuming double-extraction, analysis, and deduplication processes.

Criteria for choosing a better IDB

The rules that govern how the ETL process determines the time slices within an extraction cycle, as well as how it selects the best IDB source for each time slice, are designed to minimize both data loss and the number of switchovers from one IDB to another. For more information about the criteria for choosing the best IDB source for a particular time period, see the High Availability chapter in the [Genesys Info Mart 8.1 Deployment Guide](#).

Important

Genesys Info Mart requires ICON to write session information to the IDBs, whether or not your environment is HA. For information about the ICON configuration settings that Genesys Info Mart requires, see [Preparing the ICON Application](#) in the [Genesys Info Mart Deployment Guide](#).

Preventing data quality issues when restarting ICON

An HA configuration can eliminate multimedia data-quality issues that might arise as a result of setting the **calls-in-the-past** ICON configuration option to the required value of 1 (or true).

If you need to restart a multimedia ICON — for example, to install an upgrade — and you do not have an HA configuration, information about previous parties and first values of user data keys might be missing or inaccurate. Genesys recommends that you use an HA configuration, which eliminates these issues.

For additional information about potential data-quality issues for multimedia ICONs, see the discussion about special considerations when restarting a Multimedia ICON on the [Managing ICON and data sources](#) page in the [Genesys Info Mart Operations Guide](#).